

**CHARTER TOWNSHIP OF YPSILANTI
MINUTES OF THE DECEMBER 5, 2017 REGULAR BOARD MEETING**

Supervisor Stumbo called the meeting to order at approximately 7:05 p.m. in the Ypsilanti Township Civic Center Board Room, 7200 S. Huron River Drive, Ypsilanti Township. The Pledge of Allegiance was recited followed by a moment of silent prayer.

Members Present: Supervisor Brenda L. Stumbo, Treasurer Larry Doe,
Trustees: Stan Eldridge, Jimmie Wilson, Jr,
Monica Ross-Williams

Members Absent: Clerk Karen Lovejoy Roe, Trustee Heather Jarrell Roe

Legal Counsel: Wm. Douglas Winters

**RECOGNITION OF LINCOLN HIGH SCHOOL FOOTBALL TEAM – MHSAA
DISTRICT CHAMPIONS PROCLAMATION (see attached)**

Supervisor Stumbo presented a proclamation to the Lincoln High School Football Team in honor of their unprecedented successful football season. Head Coach Chris Westfall accepted on behalf of the team. Supervisor Stumbo stated she is a former Railsplitter and that the Board and entire township is very proud of the team's accomplishments this year. Coach Westfall thanked the Board for their support and said they hoped to do even better next year and to be invited back again.

Trustee's Wilson and Eldridge offered their congratulations to the Coach Westfall and the team.

PUBLIC HEARING

**A. 7:00PM – RESOLUTION 2017-31, 2018 FISCAL YEAR BUDGET
(PUBLIC HEARING SET AT THE NOVEMBER 21, 2017 REGULAR MEETING)**

The Public Hearing opened at 7:16PM.

Treasurer Doe suggested in the future the Residential Services Director should use a Township vehicle and the car allowance be given Supervisor Stumbo. He said Supervisor Stumbo attends many meetings with her own vehicle and it causes wear and tear on her vehicle. He stated \$3,000.00 should be taken from Residential Services Administration Fund 762 and put in Supervisor Fund 171.

The Public Hearing closed at 7:22PM.

Deputy Clerk Stanfield read Resolution 2017-31, 2018 Fiscal Year Budget.

A motion was made by Treasurer Doe, supported by Trustee Wilson to Approve Resolution 2017-31, 2018 Fiscal Year Budget with the following changes: \$3,000.00 transferred from Residential Services Administration Fund 762 to Supervisor Fund 171 for Supervisors' car allowance (see attached).

**CHARTER TOWNSHIP OF YPSILANTI
MINUTES OF THE DECEMBER 5, 2017 REGULAR BOARD MEETING
PAGE 2**

The motion carried unanimously.

PUBLIC COMMENTS

There were no public comments.

CONSENT AGENDA

A. MINUTES OF THE NOVEMBER 21, 2017 WORK SESSION, REGULAR MEETING AND CLOSED SESSION

B. STATEMENTS AND CHECKS

1. STATEMENTS AND CHECKS FOR DECEMBER 5, 2017 IN THE AMOUNT OF \$628,021.91

A motion was made by Treasurer Doe, supported by Trustee Eldridge to Approve the Consent Agenda.

The motion carried unanimously.

ATTORNEY REPORT

A. GENERAL LEGAL UPDATE

Attorney Winters stated SBA Communications is sending out the final closing documents for the two cell towers that we negotiated for a sum of \$740,000.00. He said this sale would pay off the debt for the Seaver Farm.

OLD BUSINESS

1. REQUEST OF KIRK SHERWOOD II, DIRECTOR OF GOLF FOR APPROVAL OF 2018 GOLF COURSE RATES AND APPROVAL OF THE CART STORAGE CONTRACT (TABLED AT THE NOVEMBER 21, 2017 REGULAR MEETING)

A motion was made by Trustee Ross-Williams, supported by Trustee Eldridge to remove request from Table.

Eldridge:	Yes	Ross-Williams:	Yes	Stumbo:	Yes
Doe:	Yes	Wilson:	Yes		

Kirk Sherwood II, Director of Golf stated he went over the rates again. He said if he kept the annual golf membership rate at \$500.00 for members he felt it would be going backwards because all the costs are going up and therefore, it would be losing even more revenue than last year. He said going up \$25.00 does not right the budget but it would be fair at \$525.00 and that would be for seniors. He said the non-senior rate would go up to \$575.00. He said about 85% of the members

**CHARTER TOWNSHIP OF YPSILANTI
MINUTES OF THE DECEMBER 5, 2017 REGULAR BOARD MEETING
PAGE 3**

are seniors. He said for the 5-day annual membership he left the spouse rate at \$225.00. Mr. Sherwood said for the 7-day he increased it by \$50.00 because they get two more days of play. He said he went from \$355.00 to \$375.00 for the non-resident rate.

Supervisor Stumbo read an email from Mittie McMaster, Resident. She said that Kirk Sherwood was offering residents \$525.00 and non-resident \$575.00 for senior members. She said this was a good compromise. She said there was not a 7-day senior rate discussed but thought this would be something that needs to be addressed in the future. Ms. McMaster said she appreciates Kirk considering the members input as he continues to look for ways to improve revenue. She said in May 2014 our golf cart was grandfathered in for storage at the rate of \$250.00. Ms. McMaster said her and her husband appreciates this service and agrees to the \$50.00 increase for 2018. She said she would like to thank the greens and clubhouse staff, a special shout out to the Monday Crew, Darcy Slaven and Kate Hines; our ladies league appreciated how welcoming they made us feel always going the extra mile. She said they hope to return next year and look forward to seeing Darcy and Kate **(see attached)**.

Darlene Devall, Resident stated she only plays about once a week but her husband plays every day, she does not think its fair to pay for seven days when she only plays about once a week.

Trustee Ross-Williams stated she appreciates Kirk coming up with a senior discount.

Supervisor Stumbo questioned if the senior rate was available to anyone 60 years or older. Mr. Sherwood said that it was and the senior resident rate went up \$25.00 and the non-senior resident rate went up \$75.00. Supervisor Stumbo stated that Mr. Sherwood would look into the golf simulator and beverage cart as other ways to increase revenue.

A motion was made by Trustee Ross-Williams, supported by Treasurer Doe to Approve Request of Kirk Sherwood II, Director of Golf for Approval of 2018 Golf Course Rates and Approval of the Cart Storage Contract.

The motion carried unanimously.

NEW BUSINESS

1. BUDGET AMENDMENT #17

A motion was made by Treasurer Doe, supported by Trustee Eldridge to Approve Budget Amendment #17 (see attached).

The motion carried unanimously.

**CHARTER TOWNSHIP OF YPSILANTI
MINUTES OF THE DECEMBER 5, 2017 REGULAR BOARD MEETING
PAGE 4**

2. RESOLUTION 2017-11, REAFFIRMING RESOLUTION 2015-04, ADOPTION OF HOUSING AFFORDABILITY AND ECONOMIC EQUITY ANALYSIS FOR WASHTENAW COUNTY

A motion was made by Treasurer Doe, supported by Trustee Wilson to Approve Resolution 2017-11, Reaffirming Resolution 2015-04, Adoption of Housing Affordability and Economic Equity Analysis for Washtenaw County (see attached).

The motion carried unanimously.

3. REQUEST OF KAREN WALLIN, HUMAN RESOURCES TO EXTEND THE AFSCME BARGAINING UNIT CONTRACTS (TOWNSHIP AND 14B AND THE TEAMSTERS BARGAINING UNIT CONTRACT, IF NEEDED, FOR A PERIOD OF NINETY (90) DAYS THROUGH MARCH 31, 2018

A motion was made by Treasurer Doe, supported by Trustee Ross-Williams to Approve Request of Karen Wallin, Human Resources to Extend the AFSCME Bargaining Unit Contracts (Township and 14B) and the Teamsters Bargaining Unit Contract, if Needed, for a Period of Ninety (90) Days Through March 31, 2018.

The motion carried unanimously.

4. REQUEST OF KAREN WALLIN, HR FOR AUTHORIZATION TO POST AND FILL THE COMMUNITY ENGAGEMENT COORDINATOR POSITION WITHIN THE TEAMSTER BARGAINING UNIT.

A motion was made by Trustee Ross-Williams, supported by Treasurer Doe to Approve Request of Karen Wallin, HR for Authorization to Post and Fill the Community Engagement Coordinator Position within the Teamsters Bargaining Unit.

Karen Wallin, HR Generalist, stated this was restoring a position within the Teamsters Bargaining Unit. She said this position would be posted internally and externally and would be a full time position.

Trustee Eldridge asked if this could be a non-union position. Ms. Wallin stated this position is listed as a part of the Teamsters Contract. Trustee Eldridge stated he wanted to make sure there was transparency with this job and that we enforce our nepotism policy with this job. He said he has heard people were already seeking this position for relatives and he said he was concerned about it. He said he would like to get someone that does not have ties to the Township because sometimes it seems as though we only hire friends and relatives. Trustee Eldridge said that he heard a board member has already approached some members regarding hiring a relative for this position. Karen Wallin stated she was not been approached by anyone regarding this position. She said she would advertise the position, strongly. She said they would review all applicants, assign an interview panel, conduct the interviews and proceed.

**CHARTER TOWNSHIP OF YPSILANTI
MINUTES OF THE DECEMBER 5, 2017 REGULAR BOARD MEETING
PAGE 5**

Trustee Eldridge asked if there was time to work on our policy before that because currently it states that a relative cannot supervise a relative and asked if that was correct. Karen Wallin stated that was correct. Trustee Eldridge asked how we could make sure this does not continue to happen when we have vacant positions. He said he would like to look into this further. He said that he was trying not to use names or be specific but he thought everyone understood what he was saying or he said he hoped they did.

Supervisor Stumbo stated that the nepotism policy states that an employee cannot supervise a relative. Trustee Eldridge stated that at the end of the day the Board supervises everyone. Karen Wallin stated there is a board meeting on December 19, 2017, if the Board would like to amend or make changes in the policy they could because this position will not be filled by then. Supervisor Stumbo stated she was excited to restore this position. She said with a new full time person in this position they would be able to make the Community Engagement position better. She said the position will be posted both internally and externally simultaneously and the salary was set at \$41,600.00. She said the position will be posted on December 6, 2017. Karen Wallin stated she would meet with Trustee Eldridge regarding his concerns. Trustee Ross-Williams stated one of the duties for this position states they would produce a newsletter and she wondered if it was for all of Ypsilanti Township and Supervisor Stumbo said it would be only for Neighborhood Watch meetings.

The motion carried unanimously.

5. RESOLUTION 2017-32, ADOPTION OF ANNUAL EXEMPTION OPTION AS SET FORTH IN 2011 PUBLIC ACT 152, THE PUBLICLY FUNDED HEALTH INSURANCE CONTRIBUTION ACT

A motion was made by Trustee Wilson, supported by Treasurer Doe to Approve Resolution 2017-32, Adoption of Annual Exemption Option as set forth in 2011 Public Act 152, the Publicly Funded Health Insurance Contribution Act (see attached).

The motion carried unanimously.

6. REQUEST OF ANGELA VERGES, RECREATION SERVICES MANAGER FOR AUTHORIZATION TO ACCEPT THE HELEN MCCALLA FOUNDATION GRANT IN THE AMOUNT OF \$24,819.68 FOR RENOVATION OF THE PLAY AREA LOCATED OUTSIDE THE 100 WING OF THE COMMUNITY CENTER AND TO REMOVE AND SCRAP THE PLAY EQUIPMENT CURRENTLY IN THAT AREA

A motion was made by Treasurer Doe, supported by Trustee Wilson to Approve Request of Angela Verges, Recreation Services Manager for Authorization to Accept the Helen McCalla Foundation Grant in the Amount of \$24,819.68 for Renovation of the Play Area Located outside the 100 Wing of the Community Center and to Remove and Scrap the Play Equipment Currently in that Area (see attached).

**CHARTER TOWNSHIP OF YPSILANTI
MINUTES OF THE DECEMBER 5, 2017 REGULAR BOARD MEETING
PAGE 6**

The motion carried unanimously.

7. REQUEST OF WAYNE DUDLEY, PUBLIC SERVICES SUPERINTENDENT FOR APPROVAL OF MEMBERSHIP WITH NATIONAL JOINT POWERS ALLIANCE (NJPA)

A motion was made by Trustee Wilson, supported by Trustee Ross-Williams to Approve Request of Wayne Dudley, Public Services Superintendent for Approval of Membership with National Joint Powers Alliance (NJPA).

Jeff Allen, Residential Services Director, stated he was here to represent Wayne Dudley and to answer any questions the Board may have regarding this membership. He said it was like all the other memberships we belong to. He said joining NJPA allows us to purchase fuel systems, fueling gas tanks and pumps with the group and receive better rates. Supervisor Stumbo asked if we join would we have to use a certain supplier. Mr. Allen stated we do not have to use a certain company but we would get the best pricing because we were a member of NJPA.

Javonna Neel, Accounting Director, said she had looked at this information and saw many companies and municipalities in our area were members of this group.

Supervisor Stumbo said she would like this tabled.

A motion was made by Treasurer Doe, supported by Trustee Ross-Williams to table this until the next meeting.

Eldridge:	Yes	Ross-Williams:	Yes	Stumbo:	Yes
Doe:	Yes	Wilson:	Yes		

8. REQUEST TO APPROVE PURCHASE AGREEMENT WITH DTE FOR INSTALLATION OF THIRTY TWO (32) STREETLIGHTS AS DESCRIBED IN THE PURCHASE AGREEMENT TO BE LOCATED ALONG N. HARRIS RD. BETWEEN MICHIGAN AVE. AND HOLMES RD. IN THE AMOUNT OF \$170,170.43 TO BE PAID FROM THE PREPAID ACCOUNT AND TO BE BUDGETED WITH A BUDGET AMENDMENT IN JANUARY 2018

A motion was made by Trustee Eldridge, supported by Treasurer Doe to Approve Request to Approve Purchase Agreement with DTE for Installation of Thirty Two (32) Streetlights as Described in the Purchase Agreement to be Located along N. Harris Rd. Between Michigan Ave. and Holmes Rd. in the Amount of \$170,170.43 to be Paid from the Prepaid Account and to be Budgeted with a Budget Amendment in January 2018 (see attached).

The motion carried unanimously.

**CHARTER TOWNSHIP OF YPSILANTI
MINUTES OF THE DECEMBER 5, 2017 REGULAR BOARD MEETING
PAGE 7**

- 9. REQUEST TO APPROVE PURCHASE AGREEMENT WITH DTE FOR INSTALLATION OF THIRTY ONE (31) STREETLIGHTS AS DESCRIBED IN THE PURCHASE AGREEMENT TO BE LOCATED ALONG VETERANS MEMORIAL DRIVE AND IN THE PARKING LOT AT THE CIVIC CENTER IN THE AMOUNT OF \$130,022.01 TO BE PAID FROM THE PREPAID ACCOUNT AND TO BE BUDGETED WITH A BUDGET AMENDMENT IN JANUARY 2018**

A motion was made by Trustee Wilson, supported by Trustee Eldridge to Approve Purchase Agreement with DTE for Installation of Thirty One (31) Streetlights as Described in the Purchase Agreement to be Located Along Veterans Memorial Drive and in the Parking Lot at the Civic Center in the Amount of \$130,022.01 to be Paid from the Prepaid Account and to be Budgeted with a Budget Amendment in January 2018 (see attached).

The motion carried unanimously.

- 10. RESOLUTION 2017-33, ADOPTION OF REGULAR BOARD MEETING DATES FOR THE 2018 CALENDAR YEAR**

A motion was made by Treasurer Doe, supported by Trustee Ross-Williams to Approve Resolution 2017-33, Adoption of Regular Board Meeting Dates for the 2018 Calendar Year (see attached)

The motion carried unanimously.

- 11. RESOLUTION 2017-34, ADOPTION OF ROBERTS RULES OF ORDER FOR 2018**

A motion was made by Trustee Wilson, supported by Trustee Ross-Williams to Approve Resolution 2017-34, Adoption of Roberts Rules of Order for 2018 (see attached).

The motion carried unanimously.

- 12. RESOLUTION 2017-35, ADOPTION OF DEPOSITORIES FOR 2018**

A motion was made by Treasurer Doe, supported by Trustee Wilson to Approve Resolution 2017-35, Adoption of Depositories for 2018 (see attached).

The motion carried unanimously.

**CHARTER TOWNSHIP OF YPSILANTI
MINUTES OF THE DECEMBER 5, 2017 REGULAR BOARD MEETING
PAGE 8**

13. RESOLUTION 2017-36, DESIGNATION OF NEWSPAPER OF CIRCULATION

A motion was made by Treasurer Doe, supported by Trustee Wilson to Approve Resolution 2017-36, Designation of Newspaper of Circulation (see attached).

The motion carried unanimously.

OTHER BUSINESS

1. REQUEST APPROVAL OF THE COLLECTIVE BARGAINING AGREEMENT BETWEEN FIREFIGHTERS LOCAL 1830 AND YPSILANTI TOWNSHIP FOR 2017 AND 2018

A motion was made by Treasurer Doe, supported by Trustee Wilson to Approve Request of the Collective Bargaining Agreement Between Firefighters Local 1830 and Ypsilanti Township for 2017 and 2018.

Attorney Winters recognized members of the negotiating team, Karen Wallin, HR, Accounting Director Neel, Chief Copeland and Treasurer Doe, Firefighter Local 1830 President Keith Harr, and he said other firefighters were fighting a fire and not able to attend.

Chief Copeland introduced their recently hired firefighter, Matthew Kaye. Mr. Kaye stated he had been a resident of the township for several years and this was the dream job for him to be a firefighter in the community where he lives and he thanked the board for giving him the opportunity to serve our community.

Mr. Harr stated the following bargaining committee members not present were Captain Anstead, Lt. Walgren, and Firefighters Garrigan and Nick Dunlape. Mr. Harr said he appreciated all the people involved who helped get this agreement finalized. Attorney Winters stated a lot of the negotiations was spent trying to go over all the issues regarding capital improvements, maintenance issues and to stay within the fiscal constraints of the Fire Fund budget. Attorney Winters recommended to the Township Board to seek additional revenue for the Fire Department, by allowing the voters of the township the chance to vote for the capital improvements the Fire Department needs. Attorney Winters suggested that a .50 millage over 5 years may be needed to be put on the ballot. He also reminded the Board that in 2014 and 2015 the firefighters received a 0% wage increase, in 2016 they received 3.0% increase, in 2017 the bargaining team is seeking a 3% increase and in 2018 the recommendation is a 2.5% wage increase. He said that if a capital improvement millage was put on the ballot and it passed the contract would provide an additional .5% wage increase for 2018 resulting in a 3% combined wage increase for 2018. Attorney Winters went over other changes in the contract.

Supervisor Stumbo stated we need these funds to make the capital improvements and we would have to get across to the residents the importance of this. She thanked the negotiations team for getting this completed.

**CHARTER TOWNSHIP OF YPSILANTI
MINUTES OF THE DECEMBER 5, 2017 REGULAR BOARD MEETING
PAGE 9**

The motion carried unanimously.

A motion was made by Trustee Eldridge, supported by Trustee Wilson to Adjourn.

The meeting was adjourned at approximately 9:00 pm.

Respectfully Submitted,

Brenda L. Stumbo, Supervisor
Charter Township of Ypsilanti

Karen Lovejoy Roe, Clerk
Charter Township of Ypsilanti

Charter Township of Ypsilanti

Proclamation

Honoring
2017 LINCOLN HIGH SCHOOL BOYS VARSITY FOOTBALL TEAM

WHEREAS, the Charter Township of Ypsilanti wishes to recognize and congratulate the 2017 Lincoln High School Boys Varsity Football Team on their outstanding winning season; and

WHEREAS, the Team's hard work and dedication resulted in a season of firsts by winning nine games in a row, making it the longest winning streak in school history; having the first home field playoff game; winning the first (and second) playoff game; winning the first MHSAA District Championship and being the highest scoring team in school history, with 345 total points; and

WHEREAS, individual awards from the Associated Press All State for Honorable Mention went to Dereck Thomason, Cameron Thompson, Matthew Moorer and to Chris Westfall for First Team Coach; and

WHEREAS, the Ann Arbor News Dream Team recognition went to Cameron Thompson, Player of the Year; Tate Mackenzie, First Team Offensive Line; Derek Thomason, First Team Defensive Back; Matthew Moorer, First Team Defensive Back; Avery Kenyon, First Team Defensive Line, William Lynn, Honorable Mention Linebacker; Jacob Campbell, Honorable Mention Linebacker; and Chris Westfall, Coach of the Year; and

WHEREAS, the Southeastern Conference recognition went to Cameron Thompson, Derek Thomason and Matthew Moorer for First Team Offense; William Lynn, Tahj Chatman, Avery Keyon and Jacob Campbell for First Team Defense; and Tate Mackenzie, Kevin Carter, Ethan Richardson and Trevon Davis received Honorable Mention; and

WHEREAS, Chris Westfall, Lincoln High School Boys Varsity Football Head Coach was presented with the Michigan High School Football Coaches Association Regional Coach of the Year Award and;

NOW, THEREFORE BE IT RESOLVED AND PROCLAIMED, the Charter Township of Ypsilanti Board of Trustees on behalf of all our residents wishes to applaud the 2017 Lincoln High School Boys Varsity Football Team on their history making season. **Go Lincoln Railsplitters!**

Dated and Signed This 5th Day of December, 2017



Brenda L. Stumbo, Supervisor

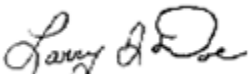

Karen Lovejoy Roe, Clerk

Larry J. Doe, Treasurer

Stan Eldridge, Trustee

Heather Jarrell Roe, Trustee

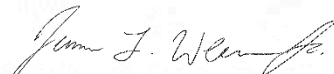
Monica Ross Williams, Trustee

Jimmie Wilson, Jr., Trustee

Resolution No. 2017-31

Charter Township of Ypsilanti 2018 Fiscal Year Budget

WHEREAS the Township Supervisor has prepared and submitted to the Township Board the proposed budgets for calendar year 2018; and

WHEREAS the Township Board has advertised the tentative millage rates in the Washtenaw Legal News and held the public hearing on December 5, 2017 on the budget and the tentative millage rates pursuant to Section 16 of the Uniform Budgeting Accounting Act (Truth in Budgeting); and

WHEREAS the Township Board has reviewed the proposed tax rates and budgets;

NOW THEREFORE BE IT RESOLVED that the Charter Township of Ypsilanti Board of Trustees adopts the 2018 Fiscal Year Budget by cost center, as follows:

Expenditures:

General Fund - Fund 101

101	Township Board	\$	146,668
137	Due Process		300,000
171	Supervisor		274,242
201	Accounting		301,480
202	Independent Auditing		32,000
209	Assessing		435,418
210	Legal Services		207,310
215	Clerk		587,997
227	Human Resources		191,750
247	Board of Review		2,055
253	Treasurer		362,464
265	Building Operations		534,050
266	Computer Support		557,277
267	General Services		185,100
371	Community Development		199,576
400	Planning Commission		6,873
410	Zoning Board of Appeals		3,345
446	Highways and Streets		385,922
762	RSD Administration		66,948
774	RSD Park and Grounds		640,695
780	RSD Storm Water Management		25,000
851	Fringes and Insurance		7,950
950	Community Stabilization		1,136,000
956	Other Functions		859,791
970	Capital Outlay		79,500
999	Other Financing Uses		870,000
Total General Fund Expenditure by Department:			\$ 8,399,411

Fire Department - Fund 206

206	Fire Department	\$	3,576,104
220	Civil Service Commission		12,520
852	Pension and Insurance		1,412,536
970	Capital Outlay		169,752
975	Federal Grant Department		-
Total Fire Department Fund by Department			Total: \$ 5,170,912

Parks Commission - Fund 208

Total: \$ 7,473

Bike Path, Sidewalk, Recreation, Roads, Operations - Fund 212

212	BSR II-Operations	\$	791,320
230	BSR II-Recreation		0
584	BSR II-Golf Course		0
970	Capital Outlay		0
991	Debt Service		666,250
Total BSR II Fund by Department			Total: \$ 1,457,570

Environmental Services - Fund 226	Total:	<u>\$ 2,764,357</u>
Recreation - Fund 230	Total:	<u>\$ 821,469</u>
14B Court - Fund 236	Total:	<u>\$ 1,903,845</u>
Housing & Business Inspection - Fund 248	Total:	<u>\$ 326,854</u>
Building Department - Fund 249	Total:	<u>\$ 706,603</u>
Local Development Finance Authority - Fund 250	Total:	<u>\$ 120,609</u>
Hydro Station - Fund 252	Total:	<u>\$ 604,275</u>
Law Enforcement - Fund 266		
301 Sheriff Services		\$ 6,906,991
304 Ordinance		362,237
Total Law Enforcement Fund by Department	Total:	<u>\$ 7,269,228</u>
Debt Fund Series B Bonds - Fund 397	Total:	<u>\$ 530,600</u>
Debt 2006 Bond - Fund 398	Total:	<u>\$ 231,600</u>
Capital Improv-Seaver Infrastr - Fund 498	Total:	<u>\$ 331,085</u>
Golf Course - Fund 584	Total:	<u>\$ 744,501</u>
Compost - Fund 590	Total:	<u>\$ 463,823</u>
Motor Pool - Fund 595	Total:	<u>\$ 248,232</u>
Nuisance Abatement - Fund 893	Total:	<u>\$ 28,097</u>
	Grand Total:	<u>\$ 32,130,544</u>
 Revenues:		
Revenues		\$ 8,477,840
Transfer-in		-
Appropriation of prior year fund balance		-
General Fund - 101	Total:	<u>\$ 8,477,840</u>
Revenues		\$ 5,133,269
Transfer-in		-
Appropriation of prior year fund balance		37,643
Fire Department Fund - 206	Total:	<u>\$ 5,170,912</u>
Revenues		\$ 7,500
Transfer-in		-
Appropriation of prior year fund balance		-
Parks Commission Fund - 208	Total:	<u>\$ 7,500</u>

Revenues	\$	1,193,758	
Transfer-in		333,000	
Appropriation of prior year fund balance		-	
Bike Path, Sidewalk, Recreation, Roads, Operations - 212	Total:	\$	<u>1,526,758</u>
Revenues	\$	2,556,134	
Transfer-in		-	
Appropriation of prior year fund balance		208,223	
Environmental Services Fund - 226	Total:	\$	<u>2,764,357</u>
Revenues	\$	313,950	
Transfer-in		507,519	
Appropriation of prior year fund balance		-	
Recreation Fund - 230	Total:	\$	<u>821,469</u>
Revenues	\$	1,979,900	
Transfer-in		-	
Appropriation of prior year fund balance		-	
14B Court - 236	Total:	\$	<u>1,979,900</u>
Revenues	\$	271,500	
Transfer-in		-	
Appropriation of prior year fund balance		55,354	
Building Rental Inspection Fund - 248	Total:	\$	<u>326,854</u>
Revenues	\$	762,300	
Transfer-in		-	
Appropriation of prior year fund balance		-	
Building Department Fund - 249	Total:	\$	<u>762,300</u>
Revenues	\$	120,709	
Transfer-in		-	
Appropriation of prior year fund balance		-	
Local Development Finance Authority Fund - 250	Total:	\$	<u>120,709</u>
Revenues	\$	389,500	
Transfer-in		-	
Appropriation of prior year fund balance		214,775	
Hydro Station Fund - 252	Total:	\$	<u>604,275</u>
Revenues	\$	7,061,764	
Transfer-in		-	
Appropriation of prior year fund balance		207,464	
Law Enforcement Fund- 266	Total:	\$	<u>7,269,228</u>
Revenues	\$	-	
Transfer-in		537,000	
Appropriation of prior year fund balance		-	
Debt Fund Series B Bonds - 397	Total:	\$	<u>537,000</u>
Revenues	\$	-	
Transfer-in		451,694	
Appropriation of prior year fund balance		-	
Debt 2006 Bond Fund - Fund 398	Total:	\$	<u>451,694</u>
Revenues	\$	500	
Transfer-in		-	
Appropriation of prior year fund balance		330,585	
Capital Improv-Seaver Infrastr - Fund 498	Total:	\$	<u>331,085</u>

Revenues	\$	500,700	
Transfer-in		193,801	
Appropriation of prior year fund balance		50,000	
Golf Course Fund - 584	Total:	\$	744,501
Revenues	\$	458,514	
Transfer-in		-	
Appropriation of prior year fund balance		5,309	
Compost Site Fund - 590	Total:	\$	463,823
Revenues	\$	237,720	
Transfer-in		-	
Appropriation of prior year fund balance		10,512	
Motorpool Fund - 595	Total:	\$	248,232
Revenues	\$	28,100	
Transfer-in		-	
Appropriation of prior year fund balance		-	
Nuisance Abatement Fund - 893	Total:	\$	28,100
Grand Total:		\$	32,636,537

Levied Property Tax Revenues and Rates:

<u>Operating</u>	<u>Rate</u>	<u>Revenue</u>
General	1.0167	\$ 1,222,171
Fire Department	3.0962	\$ 3,721,930
Solid Waste	2.1351	\$ 2,566,595
Law Enforcement	5.8952	\$ 7,086,597
Bike Path, Sidewalk, Recreation, Roads, Operation	0.9966	\$ 1,198,009
Operating Total:	13.1398	\$ 15,795,302
<u>Debt</u>		
Fire Pension	1.2000	\$ 1,442,515
Debt Total:	1.2000	\$ 1,442,515
Grand Total:	14.3398	\$ 17,237,816

The Township will levy the 1% Tax Administration fee on property taxes collected by the Township Treasurer on behalf of other governmental units, as permitted by State Law.

I, Karen Lovejoy Roe, Clerk of the Charter Township of Ypsilanti, County of Washtenaw, State of Michigan hereby certify the above resolution is a true and exact copy of Resolution No. 2017-31 approved by the Charter Township of Ypsilanti, Board of Trustees assembled at a Regular Meeting held on December 5, 2017.



Karen Lovejoy Roe, Clerk
Charter Township of Ypsilanti

Zimbra**Istanfield@ytown.org**

Re: Rate increases at Green Oaks GC

From : Karen Lovejoy Roe Mon, Dec 04, 2017 11:11 AM
<klovejoyroe@ytown.org>

Subject : Re: Rate increases at
Green Oaks GC

To : Mittie <Mitster@aol.com>

Cc : Lisa Stanfield
<Istanfield@ytown.org>

Hello Mittie,

Thank you for your email. I will include it as part of the record for the Tuesday, Dec. 5th board meeting minutes. I will also share with all our board members. Thank you for taking the time to attend our meeting and for your comments. Your input is appreciated. Take care, Karen

----- Original Message -----

From: "Mittie" <Mitster@aol.com>

To: "Brenda Stumbo" <bstumbo@ytown.org>

Cc: "Karen Lovejoy Roe"

<klovejoyroe@ytown.org>, "Larry Doe"
<l DOE@ytown.org>

Sent: Sunday, December 3, 2017 10:42:24 PM

Subject: Re: Rate increases at Green Oaks GC

Brenda,

I appreciate the opportunity given to the residents of Ypsilanti township to speak during

public comments at board meetings. I'm requesting that this email please be read at the December 5, 2017, meeting.

Due to a prior commitment, I'm unable to attend.

At the last meeting the proposed price increases for Green Oaks was tabled till the next meeting.

Upon hearing our concerns, feedback from some board members and attempting to find a win win situation for the golf course and the residents. Kirk Sherwood, Director of Golf has proposed a 5 day senior rate of \$525 and non senior rate of \$575 offering a discount rate for senior members even though it includes a \$25 increase. As most golf courses offer senior discount membership rates, I believe this is a good compromise as the golf course moves forward. Since there was no proposal to increase 7 day rates there was no discussion to offer senior rates for 7 day memberships. This may be something that needs to be address in the future. As a senior resident, I appreciate Kirk considering members input as he continues to look for ways to improve revenue at Green Oaks.

In May 2014 our golf carts were grandfathered in for storage at the rate of \$250.

My husband and I appreciate the opportunity to use this service and are in agreement with the \$50 increase for 2018.

Last but not least, I'd like to thank the Green Oaks clubhouse staff. A special shout out to the Monday crew, Darcy Slaven and Cade Hines.

Our ladies league appreciated how welcoming they made us feel, always going the extra mile. We hope to return next year and look forward to seeing Darcy and Cade.

Thank you for reading and listening to my concerns.

Best regards,

Mittie McMaster
1180 E Forest Ave
Ypsilanti, Mi 48198

Sent from Mittie's ipad

--

Karen Lovejoy Roe

Clerk

Charter Township of Ypsilanti

7200 S. Huron River Dr.

Ypsilanti, MI 48197

734.484.4700

[<mailto:klovejoyroe@ytown.org> |

klovejoyroe@ytown.org]

For Ypsilanti Township News go to

[<http://ytown.org/> | ytown.org]

**CHARTER TOWNSHIP OF YPSILANTI
2017 BUDGET AMENDMENT #17**

December 5, 2017

101 - GENERAL OPERATIONS FUND

Total Increase \$1,579.00

Request to increase budget for PTO payout request over the budgeted 32 hours, an additional 72 hours to be paid at 75%. This will be funded by an Appropriation of Prior Year Fund Balance.

Revenues:	Prior Year Fund Balance	101-000-000-699.000	\$1,579.00
		Net Revenues	<u><u>\$1,579.00</u></u>
Expenditures:	HR Salaries pay out -PTO	101-227-000-708.004	\$1,467.00
	FICA	101-227-000-715.000	\$112.00
		Net Expenditures	<u><u>\$1,579.00</u></u>

Request to increase budget and create a new line to allow for a transfer into the General Fund from the State Grant Fund. The State Grant Fund has not been used since 2008. The funds that are remaining belong to the General Fund. I am requesting to close the State Grant Fund in the amount of \$18,517.15 plus any interest earned (anticipating \$13.85 for November) and transfer to the General Fund. This will increase the revenue and decrease the amount appropriated to prior year fund balance.

Revenues:	Transfer In: State Grant Funds	101-000-000-697.010	\$18,531.00
	Prior Year Fund Balance	101-000-000-699.000	<u><u>(\$18,531.00)</u></u>
		Net Revenues	<u><u>\$0.00</u></u>

280 STATE GRANT FUND

Total Increase \$18,531.00

Request to increase budget and create a new line to allow for a transfer from the State Grant Fund into the General Fund. The State Grant Fund has not been used since 2008. The funds that are remaining belong to the General Fund. I am requesting to close the State Grant Fund in the amount of \$18,517.15 plus any interest earned (anticipating \$13.85 for November) and transfer to the General Fund. This will be funded from an appropriated to prior year fund balance.

Revenues:	Prior Year Fund Balance	280-000-000-699.000	\$18,531.00
		Net Revenues	<u><u>\$18,531.00</u></u>
Expenditures:	Transfer Out to: General Fund	280-970-000-969.101	\$18,531.00
		Net Expenditures	<u><u>\$18,531.00</u></u>

Motion to Amend the 2017 Budget (#17):

Move to increase the General Fund budget by \$1,579 to \$11,174,306 and approve the department line item changes as outlined.

Move to increase the State Grant Fund by \$18,531 to \$18,531 and approve the department line item changes as outlined.

CHARTER TOWNSHIP OF YPSILANTI

Resolution No.2017-11

Adoption of Housing Affordability and Economic Equity - Analysis for Washtenaw County

WHEREAS the Washtenaw County Office of Community and Economic Development undertook an analysis of housing market conditions throughout the community, with support from the City of Ann Arbor, the U.S. Department of Housing and Urban Development and the Ann Arbor Downtown Development Authority; and

WHEREAS the report from that analysis provides information from stakeholder interviews, surveys, and data analysis describing a widening imbalance in the housing markets of Washtenaw County, and particularly the urbanized area; and

WHEREAS the report provides findings as well as targets and implementation strategies that can be considered to improve the balance of markets and the access of lower income households throughout the community; and

WHEREAS the Ypsilanti Township Board of Trustees is committed to promoting those policies that create resiliency, promote equity and improve opportunity for households of all income levels throughout the County.

NOW THEREFORE BE IT RESOLVED that Ypsilanti Township hereby adopts the Housing Affordability and Equity - Analysis for Washtenaw County; and

BE IT FURTHER RESOLVED that the Board of Trustees commits to advancing the goals of this analysis to promote balance in the County's housing market through policy and resource allocations, partnerships and collaborations throughout the County and through a goal of providing services to all County residents, inclusive of the most vulnerable; and

BE IT FURTHER RESOLVED that the Board of Trustees reaffirms the adoption and implementation of the 2015 Housing Affordability and Economic Equity- Analysis for Washtenaw County.

I, Karen Lovejoy Roe, Clerk of the Charter Township of Ypsilanti, County of Washtenaw, State of Michigan hereby certify the above resolution is a true and exact copy of Resolution No. 2017-11 approved by the Charter Township of Ypsilanti, Board of Trustees assembled at a Regular Meeting held on December 5, 2017.

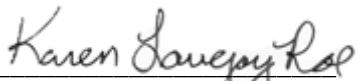
Karen Lovejoy Roe, Clerk
Charter Township of Ypsilanti

Charter Township of Ypsilanti

Resolution 2017-32

RESOLUTION TO ADOPT THE ANNUAL EXEMPTION OPTION AS SET FORTH IN 2011 PUBLIC ACT 152, THE PUBLICLY FUNDED HEALTH INSURANCE CONTRIBUTION ACT

WHEREAS, 2011 Public Act 152 (the "Act") was passed by the State Legislature and signed by the Governor on September 24, 2011;

WHEREAS, the Act contains three options for complying with the requirements of the Act;

WHEREAS, the three options are as follows:

- 1) Section 3 - "Hard Caps" Option - limits a public employer's total annual health care costs for employees based on coverage levels, as defined in the Act;
- 2) Section 4 - "80%/20%" Option - limits a public employer's share of total annual health care costs to not more than 80%. This option requires an annual majority vote of the governing body;
- 3) Section 8 - "Exemption" Option - a local unit of government, as defined in the Act, may exempt itself from the requirements of the Act by an annual 2/3 vote of the governing body;

WHEREAS, the Charter Township of Ypsilanti Board of Trustees has decided to adopt the annual Exemption option as its choice of compliance under the Act;

NOW, THEREFORE, BE IT RESOLVED the Charter Township of Ypsilanti Board of Trustees of the Charter Township of Ypsilanti elects to comply with the requirements of 2011 Public Act 152, the Publicly Funded Health Insurance Contribution Act, by adopting the annual Exemption option for the medical benefit plan coverage year January 1, 2018 through December 31, 2018.

I, Karen Lovejoy Roe, Clerk of the Charter Township of Ypsilanti, County of Washtenaw, State of Michigan hereby certify the above resolution is a true and exact copy of Resolution No. 2017-32 approved by the Charter Township of Ypsilanti, Board of Trustees assembled at a Regular Meeting held on December 5, 2017.

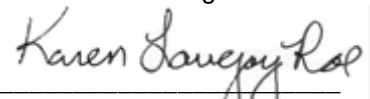

Karen Lovejoy Roe, Clerk
Charter Township of Ypsilanti

Exhibit A to Master Agreement

Purchase Agreement

This Purchase Agreement (this "Agreement") is dated as of November 27, 2017 between The Detroit Edison Company ("Company") and Charter Township of Ypsilanti ("Customer").

This Agreement is a "Purchase Agreement" as referenced in the Master Agreement for Municipal Street Lighting dated March 28, 2013 (the "Master Agreement") between Company and Customer. All of the terms of the Master Agreement are incorporated herein by reference. In the event of an inconsistency between this Agreement and the Master Agreement, the terms of this Agreement shall control.

Customer requests the Company to furnish, install, operate and maintain street lighting equipment as set forth below:

1. DTE Work Order Number:	48957073	
	If this is a conversion or replacement, indicate the Work Order Number for current installed equipment: N/A	
2. Location where Equipment will be installed:	Along N Harris Rd between Michigan Ave & Holmes Rd in Ypsilanti Township, as more fully described on the map attached hereto as <u>Attachment 1</u> .	
3. Total number of lights to be installed:	32	
4. Description of Equipment to be installed (the " <u>Equipment</u> "):	Install (32) stock 39 watt Granville acorn LED fixtures with black housings mounted on stock 11'6" Mainstreet fiberglass fluted posts with concrete foundations.	
5. Estimated Total Annual Lamp Charges	<u>Ypsilanti Township:</u> 32 UG X \$293.48 per light = \$9,391.36	
6. Computation of Contribution in aid of Construction (" <u>CIAC Amount</u> ")	Total estimated construction cost, including labor, materials, and overhead:	\$198,344.51
	Credit for 3 years of lamp charges:	\$28,174.08
	CIAC Amount (cost minus revenue)	\$170,170.43
7. Payment of CIAC Amount:	Due promptly upon execution of this Agreement	
8. Term of Agreement	5 years. Upon expiration of the initial term, this Agreement shall continue on a month-to-month basis until terminated by mutual written consent of the parties or by either party with thirty (30) days prior written notice to the other party.	
9. Does the requested Customer lighting design meet IESNA recommended practices?	(Check One) <input type="checkbox"/> YES <input checked="" type="checkbox"/> NO If "No", Customer must sign below and acknowledge that the lighting design does not meet IESNA recommended practices Signature: <i>Brenda L. Stumbo / Karen Lovejoy Roe</i>	
10. Customer Address for Notices:	Charter Township of Ypsilanti 7200 S Huron River Dr Ypsilanti, MI 48197 Attn: Karen Lovejoy Roe	

11. Special Order Material Terms:

All or a portion of the Equipment consists of special order material: (check one) YES NO

If "Yes" is checked, Customer and Company agree to the following additional terms.

A. Customer acknowledges that all or a portion of the Equipment is special order materials ("SOM") and not Company's standard stock. Customer will purchase and stock replacement SOM and spare parts. When replacement equipment or spare parts are installed from Customer's inventory, the Company will credit Customer in the amount of the then current material cost of Company standard street lighting equipment.

B. Customer will maintain an initial inventory of at least N/A posts and N/A luminaires and any other materials agreed to by Company and Customer, and will replenish the stock as the same are drawn from inventory. Costs of initial inventory are included in this Agreement. The Customer agrees to work with the Company to adjust inventory levels from time to time to correspond to actual replacement material needs. If Customer fails to maintain the required inventory, Company, after 30 days' notice to Customer, may (but is not required to) order replacement SOM and Customer will reimburse Company for such costs. Customer acknowledges that failure to maintain required inventory could result in extended outages due to SOM lead times.

C. The inventory will be stored at N/A. Access to the Customers inventory site must be provided between the hours of 9:00 am to 4:00 pm, Monday through Friday with the exceptions of federal Holidays. Customer shall name an authorized representative to contact regarding inventory: levels, access, usage, transactions, and provide the following contact information to the Company:

Name: N/A Title: N/A

Phone Number: N/A Email: N/A

The Customer will notify the Company of any changes in the Authorized Customer Representative. The Customer must comply with SOM manufacturer's recommended inventory storage guidelines and practices. Damaged SOM will not be installed by the Company.

D. In the event that SOM is damaged by a third party, the Company may (but is not required to) pursue a damage claim against such third party for collection of all labor and stock replacement value associated with the damage claim. Company will promptly notify Customer as to whether Company will pursue such claim.

E. In the event that SOM becomes obsolete or no longer manufactured, the Customer will be allowed to select new alternate SOM that is compatible with the Company's existing infrastructure.

F. Should the Customer experience excessive LED equipment failures, not supported by LED manufacturer warranties, the Company will replace the LED equipment with other Company supported Solid State or High Intensity Discharge luminaires at the Company's discretion. The full cost to complete these replacements to standard street lighting equipment will be the responsibility of the Customer.

12. Experimental Emerging Lighting Technology ("EELT") Terms:

All or a portion of the Equipment consists of EELT: (check one) YES NO

If "Yes" is checked, Customer and Company agree to the following additional terms.

A. The annual billing lamp charges for the EELT equipment has been calculated by the Company are based upon the estimated energy and maintenance cost expected with the Customer's specific pilot project EELT equipment.

B. Upon the approval of any future MPSC Option I tariff for EELT street lighting equipment, the approved rate schedules will automatically apply for service continuation to the Customer under Option 1 Municipal Street Lighting Rate, as approved by the MPSC. The terms of this paragraph B replace in its entirety Section 7 of the Master Agreement with respect to any EELT equipment purchased under this Agreement.

Company and Customer have executed this Purchase Agreement as of the date first written above.

Company:

The Detroit Edison Company

By: _____

Name: _____

Title: _____

Customer:

Charter Township of Ypsilanti

By: Brenda L. Stumbo / Kara Lovejoy Roc

Name: Brenda L. Stumbo / Kara Lovejoy Roc

Title: Supervisor / Clerk

Attachment 1 to Purchase Agreement

Map of Location

[To be attached]

WL 33:
AAB460
IN: UG CUBE TAP

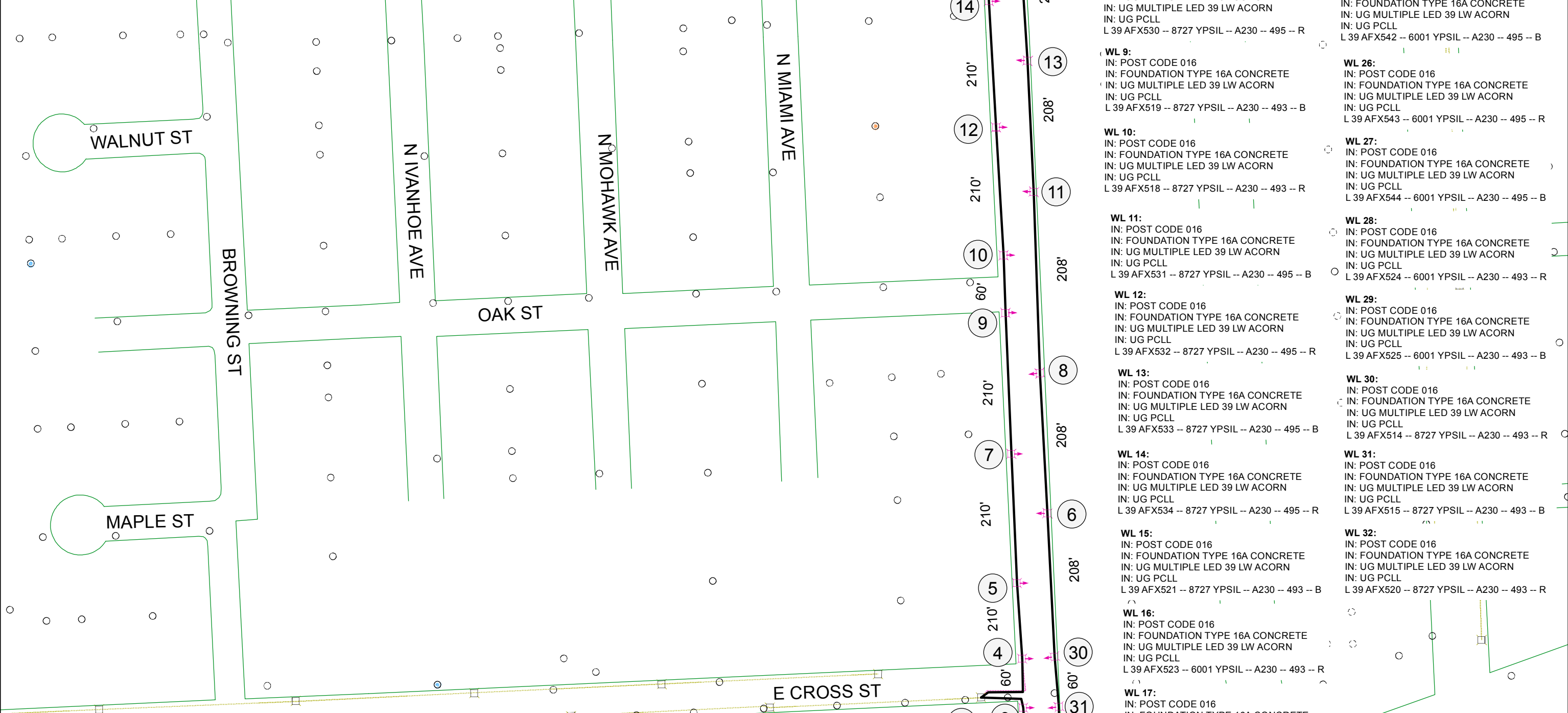
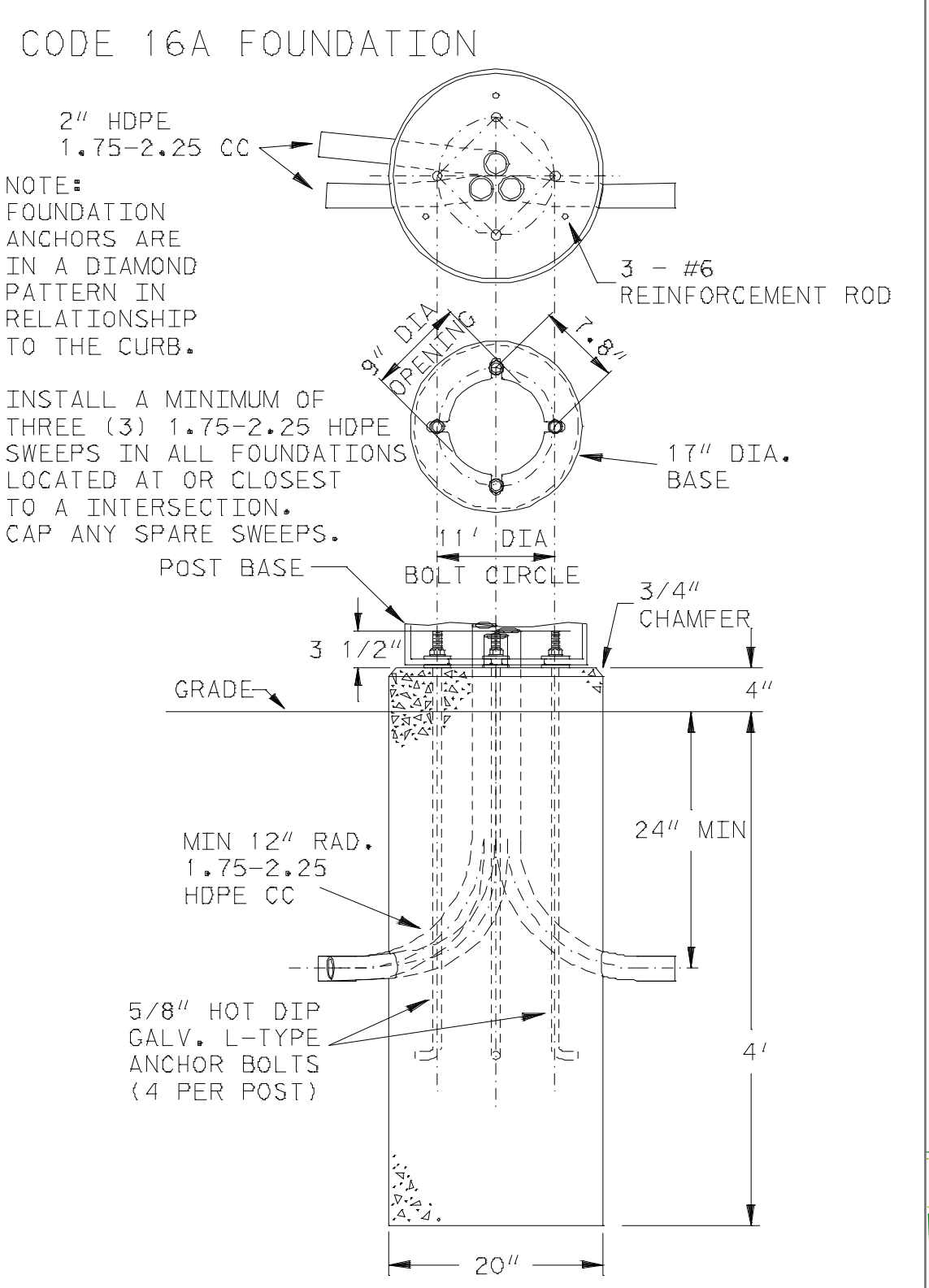
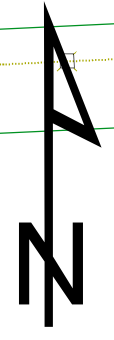
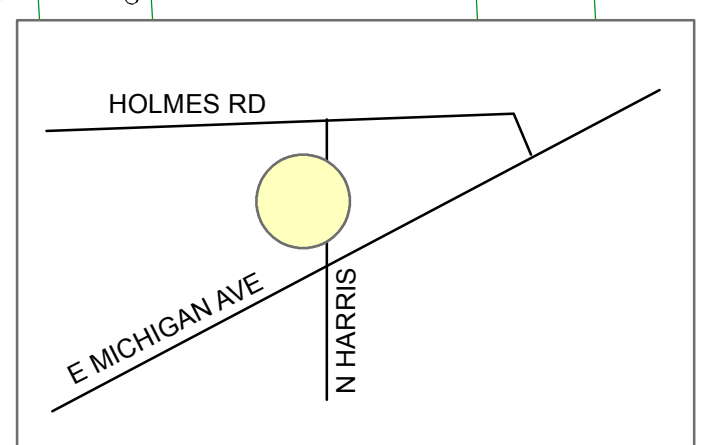

- WL 1:**
IN: POST CODE 016
IN: FOUNDATION TYPE 16A CONCRETE
IN: UG MULTIPLE LED 39 LW ACORN
IN: UG PCLL
L 39 AFX528 -- 8727 YPSIL -- A230 -- 495 -- B
- WL 2:**
IN: POST CODE 016
IN: FOUNDATION TYPE 16A CONCRETE
IN: UG MULTIPLE LED 39 LW ACORN
IN: UG PCLL
L 39 AFX517 -- 8727 YPSIL -- A230 -- 493 -- R
- WL 3:**
IN: POST CODE 016
IN: FOUNDATION TYPE 16A CONCRETE
IN: UG MULTIPLE LED 39 LW ACORN
IN: UG PCLL
L 39 AFX516 -- 8727 YPSIL -- A230 -- 493 -- B
- WL 4:**
IN: POST CODE 016
IN: FOUNDATION TYPE 16A CONCRETE
IN: UG MULTIPLE LED 39 LW ACORN
IN: UG PCLL
L 39 AFX513 -- 8727 YPSIL -- A230 -- 493 -- R
- WL 5:**
IN: POST CODE 016
IN: FOUNDATION TYPE 16A CONCRETE
IN: UG MULTIPLE LED 39 LW ACORN
IN: UG PCLL
L 39 AFX527 -- 8727 YPSIL -- A230 -- 495 -- B
- WL 6:**
IN: POST CODE 016
IN: FOUNDATION TYPE 16A CONCRETE
IN: UG MULTIPLE LED 39 LW ACORN
IN: UG PCLL
L 39 AFX528 -- 8727 YPSIL -- A230 -- 495 -- R
- WL 7:**
IN: POST CODE 016
IN: FOUNDATION TYPE 16A CONCRETE
IN: UG MULTIPLE LED 39 LW ACORN
IN: UG PCLL
L 39 AFX529 -- 8727 YPSIL -- A230 -- 495 -- B
- WL 8:**
IN: POST CODE 016
IN: FOUNDATION TYPE 16A CONCRETE
IN: UG MULTIPLE LED 39 LW ACORN
IN: UG PCLL
L 39 AFX530 -- 8727 YPSIL -- A230 -- 495 -- R
- WL 9:**
IN: POST CODE 016
IN: FOUNDATION TYPE 16A CONCRETE
IN: UG MULTIPLE LED 39 LW ACORN
IN: UG PCLL
L 39 AFX519 -- 8727 YPSIL -- A230 -- 493 -- B
- WL 10:**
IN: POST CODE 016
IN: FOUNDATION TYPE 16A CONCRETE
IN: UG MULTIPLE LED 39 LW ACORN
IN: UG PCLL
L 39 AFX518 -- 8727 YPSIL -- A230 -- 493 -- R
- WL 11:**
IN: POST CODE 016
IN: FOUNDATION TYPE 16A CONCRETE
IN: UG MULTIPLE LED 39 LW ACORN
IN: UG PCLL
L 39 AFX531 -- 8727 YPSIL -- A230 -- 495 -- B
- WL 12:**
IN: POST CODE 016
IN: FOUNDATION TYPE 16A CONCRETE
IN: UG MULTIPLE LED 39 LW ACORN
IN: UG PCLL
L 39 AFX532 -- 8727 YPSIL -- A230 -- 495 -- R
- WL 13:**
IN: POST CODE 016
IN: FOUNDATION TYPE 16A CONCRETE
IN: UG MULTIPLE LED 39 LW ACORN
IN: UG PCLL
L 39 AFX533 -- 8727 YPSIL -- A230 -- 495 -- B
- WL 14:**
IN: POST CODE 016
IN: FOUNDATION TYPE 16A CONCRETE
IN: UG MULTIPLE LED 39 LW ACORN
IN: UG PCLL
L 39 AFX534 -- 8727 YPSIL -- A230 -- 495 -- R
- WL 15:**
IN: POST CODE 016
IN: FOUNDATION TYPE 16A CONCRETE
IN: UG MULTIPLE LED 39 LW ACORN
IN: UG PCLL
L 39 AFX523 -- 6001 YPSIL -- A230 -- 493 -- R
- WL 16:**
IN: POST CODE 016
IN: FOUNDATION TYPE 16A CONCRETE
IN: UG MULTIPLE LED 39 LW ACORN
IN: UG PCLL
L 39 AFX523 -- 6001 YPSIL -- A230 -- 493 -- R
- WL 17:**
IN: POST CODE 016
IN: FOUNDATION TYPE 16A CONCRETE
IN: UG MULTIPLE LED 39 LW ACORN
IN: UG PCLL
L 39 AFX522 -- 6001 YPSIL -- A230 -- 493 -- B
- WL 18:**
IN: POST CODE 016
IN: FOUNDATION TYPE 16A CONCRETE
IN: UG MULTIPLE LED 39 LW ACORN
IN: UG PCLL
L 39 AFX535 -- 6001 YPSIL -- A230 -- 495 -- R
- WL 19:**
IN: POST CODE 016
IN: FOUNDATION TYPE 16A CONCRETE
IN: UG MULTIPLE LED 39 LW ACORN
IN: UG PCLL
L 39 AFX536 -- 6001 YPSIL -- A230 -- 495 -- B
- WL 20:**
IN: POST CODE 016
IN: FOUNDATION TYPE 16A CONCRETE
IN: UG MULTIPLE LED 39 LW ACORN
IN: UG PCLL
L 39 AFX537 -- 6001 YPSIL -- A230 -- 495 -- R
- WL 21:**
IN: POST CODE 016
IN: FOUNDATION TYPE 16A CONCRETE
IN: UG MULTIPLE LED 39 LW ACORN
IN: UG PCLL
L 39 AFX538 -- 6001 YPSIL -- A230 -- 495 -- B
- WL 22:**
IN: POST CODE 016
IN: FOUNDATION TYPE 16A CONCRETE
IN: UG MULTIPLE LED 39 LW ACORN
IN: UG PCLL
L 39 AFX539 -- 6001 YPSIL -- A230 -- 495 -- R
- WL 23:**
IN: POST CODE 016
IN: FOUNDATION TYPE 16A CONCRETE
IN: UG MULTIPLE LED 39 LW ACORN
IN: UG PCLL
L 39 AFX540 -- 6001 YPSIL -- A230 -- 495 -- B
- WL 24:**
IN: POST CODE 016
IN: FOUNDATION TYPE 16A CONCRETE
IN: UG MULTIPLE LED 39 LW ACORN
IN: UG PCLL
L 39 AFX541 -- 6001 YPSIL -- A230 -- 495 -- R
- WL 25:**
IN: POST CODE 016
IN: FOUNDATION TYPE 16A CONCRETE
IN: UG MULTIPLE LED 39 LW ACORN
IN: UG PCLL
L 39 AFX542 -- 6001 YPSIL -- A230 -- 495 -- B
- WL 26:**
IN: POST CODE 016
IN: FOUNDATION TYPE 16A CONCRETE
IN: UG MULTIPLE LED 39 LW ACORN
IN: UG PCLL
L 39 AFX543 -- 6001 YPSIL -- A230 -- 495 -- R
- WL 27:**
IN: POST CODE 016
IN: FOUNDATION TYPE 16A CONCRETE
IN: UG MULTIPLE LED 39 LW ACORN
IN: UG PCLL
L 39 AFX544 -- 6001 YPSIL -- A230 -- 495 -- B
- WL 28:**
IN: POST CODE 016
IN: FOUNDATION TYPE 16A CONCRETE
IN: UG MULTIPLE LED 39 LW ACORN
IN: UG PCLL
L 39 AFX545 -- 6001 YPSIL -- A230 -- 495 -- B
- WL 29:**
IN: POST CODE 016
IN: FOUNDATION TYPE 16A CONCRETE
IN: UG MULTIPLE LED 39 LW ACORN
IN: UG PCLL
L 39 AFX525 -- 6001 YPSIL -- A230 -- 493 -- B
- WL 30:**
IN: POST CODE 016
IN: FOUNDATION TYPE 16A CONCRETE
IN: UG MULTIPLE LED 39 LW ACORN
IN: UG PCLL
L 39 AFX514 -- 8727 YPSIL -- A230 -- 493 -- R
- WL 31:**
IN: POST CODE 016
IN: FOUNDATION TYPE 16A CONCRETE
IN: UG MULTIPLE LED 39 LW ACORN
IN: UG PCLL
L 39 AFX515 -- 8727 YPSIL -- A230 -- 493 -- B
- WL 32:**
IN: POST CODE 016
IN: FOUNDATION TYPE 16A CONCRETE
IN: UG MULTIPLE LED 39 LW ACORN
IN: UG PCLL
L 39 AFX520 -- 8727 YPSIL -- A230 -- 493 -- R

8727 YPSIL
NO TAG AT POLE

WL 35:
AP572
IN: UG CUBE TAP

Streetlight Billing Summary	
A230 - YPSILANTI TWP OF	
6001 YPSIL	IN 4 *493
6001 YPSIL	IN 10 *495
8727 YPSIL	IN 9 *493
8727 YPSIL	IN 9 *495

Created on: 11/13/2017 12:02:56 PM

Trench-Bore Summary	
Type	Length
34	5790
Total - 5790	

Cable Summary	
Type	Length
IR #2 ALX2 - #4 ALX1	6179

Created on: 11/14/2017 11:25:53 AM

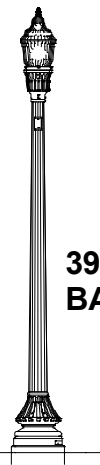

39W BLACK BASIC ACORN

CODE 016 BLACK POST

LEGEND

- SET NEW POLE
- CABLE POLE / RISER
- POSITION OF SWEEP UP CABLE POLE
- BURIED PRIMARY CABLE (ALL VOLTAGES)
- BURIED SECONDARY CABLE
- SINGLE DUCT OCCUPIED
- DOUBLE DUCT - OCCUPIED
- SINGLE DUCT-TO BLIND END FOR FUTURE USE
- ⊠ PAD-MOUNTED TRANSFORMER
- ← DIRECTION OF TRANSFORMER DOOR OPENING
- GUARD POST
- P.S.C PRIMARY SWITCH CABINET
- S.C.C SEPARABLE CONNECTION CABINET

PWO# 46470076 17 X 22

DTE Energy		DTE Electric - Distribution Engineering and Planning	
Service Planner	O'Dea, Charlotte A	Work Order Description	SL_NBUS - 32 UG - Harris Rd btwn Michigan & Holmes - Ypsilanti Twp
Phone	734.397.4307	Work Order #	49103052
Supervisor	Brian R Kinnick	GIS-DSN	49103053
Service Center	ANN	COH	49103062
Work to be Performed	JU Work to be Performed	Circuit #2	49103063
Planning Engineer	734.397.4024	PH	49103061
Worksite City	YPSILANTI	County	Washtenaw
Worksite Twp	YPSILANTI	Range	07E
Ver	1	Section	02
CUE Number	758683	Scale	NTS
Plot Date	11/17/2017	Town	03S

Exhibit A to Master Agreement

Purchase Agreement

This Purchase Agreement (this "Agreement") is dated as of November 28, 2017 between The Detroit Edison Company ("Company") and Charter Township of Ypsilanti ("Customer").

This Agreement is a "Purchase Agreement" as referenced in the Master Agreement for Municipal Street Lighting dated March 28, 2013 (the "Master Agreement") between Company and Customer. All of the terms of the Master Agreement are incorporated herein by reference. In the event of an inconsistency between this Agreement and the Master Agreement, the terms of this Agreement shall control.

Customer requests the Company to furnish, install, operate and maintain street lighting equipment as set forth below:

1. DTE Work Order Number:	48227260	
	If this is a conversion or replacement, indicate the Work Order Number for current installed equipment: N/A	
2. Location where Equipment will be installed:	Along Veterans Memorial Dr and in the parking lots at Ypsilanti Township Civic Center at 7200 S Huron River Dr, as more fully described on the map attached hereto as <u>Attachment 1</u> .	
3. Total number of lights to be installed:	31	
4. Description of Equipment to be installed (the " <u>Equipment</u> "):	<p>Install (27) new stock 135 watt Autobahn LED fixtures with black housings mounted on (23) stock 30' black steel davit arm poles with concrete foundations. Nineteen of the poles to be installed are stock black single Code 06B poles. Four of the poles to be installed are stock grey twin Code 87 poles and are to be painted black. Two of the Code 87 pole foundations to be installed in the parking lot area will require high band foundations.</p> <p>Install (4) new stock 60 watt Granville acorn LED fixtures with black housings to be mounted on (4) new stock 11'-6" black fiberglass fluted posts with concrete foundations to light the pathway near the Township building.</p> <p>Remove all existing Ypsilanti Township owned posts and fixtures along Veterans Memorial Dr and in the parking lots at Ypsilanti Township Civic Center.</p>	
5. Estimated Total Annual Lamp Charges	\$9,504.27	
6. Computation of Contribution in aid of Construction (" <u>CIAC Amount</u> ")	Total estimated construction cost, including labor, materials, and overhead:	\$158,534.82
	Credit for 3 years of lamp charges:	\$28,512.81
	CIAC Amount (cost minus revenue)	\$130,022.01
7. Payment of CIAC Amount:	Due promptly upon execution of this Agreement	
8. Term of Agreement	5 years. Upon expiration of the initial term, this Agreement shall continue on a month-to-month basis until terminated by mutual written consent of the parties or by either party with thirty (30) days prior written notice to the other party.	

<p>9. Does the requested Customer lighting design meet IESNA recommended practices?</p>	<p>(Check One) <input type="checkbox"/> YES <input checked="" type="checkbox"/> NO</p> <p>If "No", Customer must sign below and acknowledge that the lighting design does not meet IESNA recommended practices</p> <p style="text-align: center;">Signature: <i>Brenda L. Stumbo / Karen Lovejoy Roe</i></p>
<p>10. Customer Address for Notices:</p>	<p>Charter Township of Ypsilanti 7200 S Huron River Dr Ypsilanti, MI 48197 Attn: Karen Lovejoy Roe</p>

11. Special Order Material Terms:

All or a portion of the Equipment consists of special order material: (check one) YES NO

If "Yes" is checked, Customer and Company agree to the following additional terms.

A. Customer acknowledges that all or a portion of the Equipment is special order materials ("SOM") and not Company's standard stock. Customer will purchase and stock replacement SOM and spare parts. When replacement equipment or spare parts are installed from Customer's inventory, the Company will credit Customer in the amount of the then current material cost of Company standard street lighting equipment.

B. Customer will maintain an initial inventory of at least N/A posts and N/A luminaires and any other materials agreed to by Company and Customer, and will replenish the stock as the same are drawn from inventory. Costs of initial inventory are included in this Agreement. The Customer agrees to work with the Company to adjust inventory levels from time to time to correspond to actual replacement material needs. If Customer fails to maintain the required inventory, Company, after 30 days' notice to Customer, may (but is not required to) order replacement SOM and Customer will reimburse Company for such costs. Customer acknowledges that failure to maintain required inventory could result in extended outages due to SOM lead times.

C. The inventory will be stored at N/A. Access to the Customers inventory site must be provided between the hours of 9:00 am to 4:00 pm, Monday through Friday with the exceptions of federal Holidays. Customer shall name an authorized representative to contact regarding inventory: levels, access, usage, transactions, and provide the following contact information to the Company:

Name: N/A Title: N/A

Phone Number: N/A Email: N/A

The Customer will notify the Company of any changes in the Authorized Customer Representative. The Customer must comply with SOM manufacturer's recommended inventory storage guidelines and practices. Damaged SOM will not be installed by the Company.

D. In the event that SOM is damaged by a third party, the Company may (but is not required to) pursue a damage claim against such third party for collection of all labor and stock replacement value associated with the damage claim. Company will promptly notify Customer as to whether Company will pursue such claim.

E. In the event that SOM becomes obsolete or no longer manufactured, the Customer will be allowed to select new alternate SOM that is compatible with the Company's existing infrastructure.

F. Should the Customer experience excessive LED equipment failures, not supported by LED manufacturer warranties, the Company will replace the LED equipment with other Company supported Solid State or High Intensity Discharge luminaires at the Company's discretion. The full cost to complete these replacements to standard street lighting equipment will be the responsibility of the Customer.

12. Experimental Emerging Lighting Technology ("EELT") Terms:

All or a portion of the Equipment consists of EELT: (check one) YES NO

If "Yes" is checked, Customer and Company agree to the following additional terms.

A. The annual billing lamp charges for the EELT equipment has been calculated by the Company are based upon the estimated energy and maintenance cost expected with the Customer's specific pilot project EELT equipment.

B. Upon the approval of any future MPSC Option I tariff for EELT street lighting equipment, the approved rate schedules will automatically apply for service continuation to the Customer under Option 1 Municipal Street Lighting Rate, as approved by the MPSC. The terms of this paragraph B replace in its entirety Section 7 of the Master Agreement with respect to any EELT equipment purchased under this Agreement.

Company and Customer have executed this Purchase Agreement as of the date first written above.

Company:

The Detroit Edison Company

By: _____

Name: _____

Title: _____

Customer:

Charter Township of Ypsilanti

By: Brenda L. Stumbo / Karen Lovjoy Roe

Name: Brenda L. Stumbo / Karen Lovjoy Roe

Title: Supervisor / Clerk

Dec. 6, 2017

Attachment 1 to Purchase Agreement

Map of Location

[To be attached]



Know what's Below.
Call before you dig.

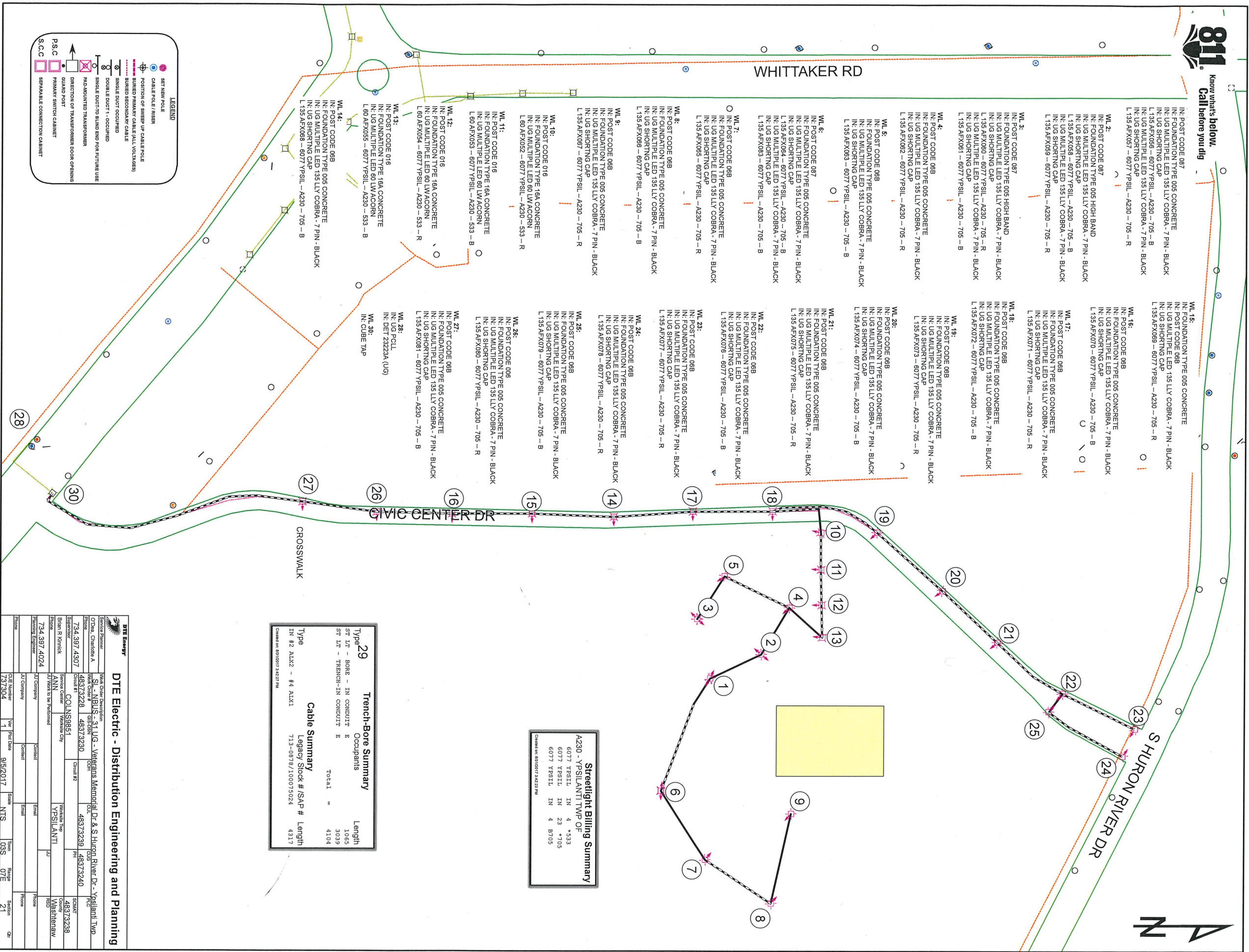

Streetlight Billing Summary
A230 - YPSILANTI TWP OF
6077 YPSIL IN 4 *533
6077 YPSIL IN 23 *705
6077 YPSIL IN 4 8705

Checked on 8/31/2017 14:22:37 PM

Trench-Bore Summary

Type	Length
SR UT - BORE - IN CONDUIT E	1065
SR UT - TRENCH-IN CONDUIT E	3039
Total	4104

Cable Summary

Type	Legacy Stock # /SAP #	Length
IN #2 ALX2 - #4 ALX1	713-0878/100015024	4317

Checked on 8/31/2017 14:22:37 PM

DTE Electric - Distribution Engineering and Planning

Project Number	734.397.4024
Client	City of Ypsilanti
Project Name	SL - NBUS - 31 UG - Veterans Memorial Dr & S Huron River Dr - Ypsilanti Twp
Project Manager	SL - NBUS - 31 UG - Veterans Memorial Dr & S Huron River Dr - Ypsilanti Twp
Project Engineer	ANN
Project Designer	ANN
Project Checker	ANN
Project Approver	ANN
Project Date	9/5/2017
Project Status	NTS
Project Scale	1" = 30'
Project Location	Ypsilanti, MI
Project Drawing	0335
Project Section	21
Project Date	9/5/2017

CHARTER TOWNSHIP OF YPSILANTI

Resolution No. 2017-33

ADOPTION OF REGULAR BOARD MEETING DATES FOR THE 2018 CALENDAR YEAR

NOW THEREFORE, BE IT RESOLVED that the attached schedule of dates and times be adopted for the Charter Township of Ypsilanti for the 2018 calendar year.

I, Karen Lovejoy Roe, Clerk of the Charter Township of Ypsilanti, County of Washtenaw, State of Michigan hereby certify the above resolution is a true and exact copy of Resolution No. 2017-33 approved by the Charter Township of Ypsilanti, Board of Trustees assembled at a Regular Meeting held on December 5, 2017.

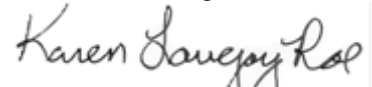

Karen Lovejoy Roe, Clerk
Charter Township of Ypsilanti

**CHARTER TOWNSHIP OF YPSILANTI
BOARD OF TRUSTEES**

SCHEDULE OF MEETINGS FOR 2018

Work Session
5:00 p.m.
Civic Center Board Room

Regular Meeting
7:00 p.m.
Civic Center Board Room

In 2018, the Township Board will meet on the 1st and 3rd Tuesday of each month in February, March, April, May, October, and December and on the 3rd Tuesday of each month in January, June, July, August, September and November.

Tuesday January 16, 2018

Tuesday February 6, 2018
Tuesday February 20, 2018

Tuesday March 6, 2018
Tuesday March 20, 2018

Tuesday April 3, 2018
Tuesday April 17, 2018

Tuesday May 1, 2018
Tuesday May 15, 2018

Tuesday June 19, 2018*

Tuesday July 17, 2018*

Tuesday August 21, 2018*

Tuesday September 18, 2018*

Tuesday October 2, 2018
Tuesday October 16, 2018

Tuesday November 20, 2018

Tuesday December 4, 2018
Tuesday December 18, 2018

All meetings are held at the Ypsilanti Township Civic Center Building, 7200 S. Huron River Drive, Ypsilanti Township

Special Meetings may be called with 24-hour notification.

Pre-approval of Statements and Checks is authorized when no Board Meeting is held, with formal approval at the next regularly scheduled meeting, contingent on Board Members review and no objection.

*Board members should plan to reserve the first Tuesday of June, July, August and September in case a Special Meeting needs to be scheduled.

CHARTER TOWNSHIP OF YPSILANTI

RESOLUTION NO. 2017-34

ADOPTION OF ROBERT'S RULES OF ORDER

NOW THEREFORE, BE IT RESOLVED that Robert's Rules of Order shall be adopted by the Charter Township of Ypsilanti Board of Trustees for the 2018 calendar year.

I, Karen Lovejoy Roe, Clerk of the Charter Township of Ypsilanti, County of Washtenaw, State of Michigan hereby certify the above resolution is a true and exact copy of Resolution No. 2017-34 approved by the Charter Township of Ypsilanti, Board of Trustees assembled at a Regular Meeting held on December 5, 2017.

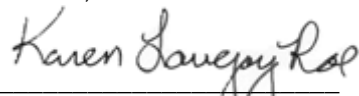

Karen Lovejoy Roe, Clerk
Charter Township of Ypsilanti

CHARTER TOWNSHIP OF YPSILANTI

RESOLUTION NO. 2017-35

**DESIGNATION OF DEPOSITORIES
FOR 2018**

NOW THEREFORE, BE IT RESOLVED that Bank of Ann Arbor-Ypsilanti Office, Comerica Bank, Charter One, Ann Arbor State Bank, Fifth Third Bank, Chase Bank, P&C Bank, United Bank & Trust, Fidelity Bank, Huntington National Bank, Key Bank and TCF Bank and their successors be designated depositories for all Charter Township of Ypsilanti funds and securities for the 2018 calendar year.

I, Karen Lovejoy Roe, Clerk of the Charter Township of Ypsilanti, County of Washtenaw, State of Michigan hereby certify the above resolution is a true and exact copy of Resolution No. 2017-35 approved by the Charter Township of Ypsilanti, Board of Trustees assembled at a Regular Meeting held on December 5, 2017.



Karen Lovejoy Roe, Clerk
Charter Township of Ypsilanti

CHARTER TOWNSHIP OF YPSILANTI

RESOLUTION NO. 2017-36

DESIGNATION OF NEWSPAPER OF CIRCULATION

NOW THEREFORE, BE IT RESOLVED that Washtenaw Legal and MLive/AnnArbor.com be designated as the newspapers of general circulation for the Charter Township of Ypsilanti advertisements and publications for the 2018 calendar year.

I, Karen Lovejoy Roe, Clerk of the Charter Township of Ypsilanti, County of Washtenaw, State of Michigan hereby certify the above resolution is a true and exact copy of Resolution No. 2017-36 approved by the Charter Township of Ypsilanti, Board of Trustees assembled at a Regular Meeting held on December 5, 2017.

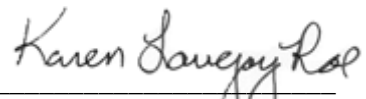

Karen Lovejoy Roe, Clerk
Charter Township of Ypsilanti