

**CHARTER TOWNSHIP OF
YPSILANTI BOARD OF TRUSTEES**

Supervisor

BRENDA L. STUMBO

Clerk

KAREN LOVEJOY ROE

Treasurer

LARRY J. DOE

Trustees

JEAN HALL CURRIE

STAN ELDRIDGE

MIKE MARTIN

SCOTT MARTIN

October 20, 2015

Work Session – 5:00 p.m.

Regular Meeting – 7:00 p.m.

**Ypsilanti Township Civic Center
7200 S. Huron River Drive
Ypsilanti, MI 48197**

		Year to Date	
	Prior Year Comparison		
Month	Revenue	Revenue	
	2014	2015	
January	\$93,424.58	\$101,726.02	
February	\$134,377.46	\$127,974.93	
March	\$116,070.56	\$119,020.09	
April	\$104,192.57	\$119,225.82	
May	\$106,156.14	\$90,046.85	
June	\$107,897.55	\$87,731.39	
July	\$101,268.87	\$103,821.60	
August	\$98,053.38	\$110,392.69	
September	\$106,365.17	\$124,547.06	
October	\$108,958.51		
November	\$81,140.04		
December	\$93,416.84		
Grant:		\$41,250.00	
Standardization			
Payment:	\$45,724.00	\$45,724.00	
Year-to Date			
Totals:	\$1,297,045.67	\$1,071,460.45	
Expenditure			
Budget:	\$1,267,085.00	\$1,328,089.00	
Difference:	\$29,960.67	(\$195,624.55)	

14-B District Court

Revenue Report for September 2015

General Account

Account Number
Due to Washtenaw County
(101-000-000-214.222) **\$3,798.50**

Due to State Treasurer

Civil Filing Fee Fund (MCL 600.171): \$17,017.00
State Court Fund (MCL 600.8371): \$1,370.00
Justice System Fund (MCL 600.181): \$21,560.00
Juror Compensation Reimbursement Fund:
 Civil Jury Demand Fee (MCL 600.8371): \$0.00
 Drivers License Clearance Fees (MCL 257.321a): \$1,573.50
Crime Victims Rights Fund (MCL 780.905): \$5,685.75
Judgment Fee (Dept. of Natural Resources): \$0.00
Due to Secretary of State
(101-000-000-206.136) \$1,575.00

Total: **\$48,781.25**

Due to Ypsilanti Township

Court Costs (101-000-000-602.136): \$38,823.29
Civil Fees (101-000-000-603.136): \$35,258.00
Probation Fees (101-000-000-604.000): \$5,935.50
Ordinance Fines (101-000-000-605.001): \$42,198.00
Bond Forfeitures (101-000-000-605.003): \$2,710.00
Interest Earned (101-000-000-605.004): \$0.00
State Aid-Caseflow Assistance (101-000-602.544): \$0.00
Expense Write-Off: \$0.00
Bank Charges (Expense - 101.136.000.957.000): (\$377.73)

Total: **\$124,547.06**

Total to General Account - (101.000.000.004.136): \$177,126.81

Escrow Account

(101-000-000-205.136)

Court Ordered Escrow: \$4,514.00
Garnishment Proceeds: \$0.00
Bonds: \$9,924.00
Restitution: \$7,830.42

Total to Escrow Account - (101.000.000.205.136): \$22,268.42

14-B District Court

Monthly Disbursements

September 2015

Revenue received as a Fine for violation of a State Statute is disbursed to the Washtenaw County Treasurer, for library purposes.

Revenue received as a Fine for violation of a Township Ordinance and all Court Costs are disbursed to the Ypsilanti Township Treasurer. Local revenue also includes Probation oversight fees and Bond Forfeitures.

Revenue received as State Filing Fee, State Court Fund, Justice System Fund, Juror Compensation, Crime Victims Rights Fund and Dept. of Natural Resources Judgment Fee is forwarded to the State Treasurer.

Money received as Garnishment Proceeds, Criminal Bonds, Restitution, and Court Ordered Escrow are deposited in the Escrow Account of the Court.

All other revenues are transferred to the Ypsilanti Township Treasurer.

September 2015 Disbursements:

Washtenaw County:	\$ 3,798.50
State of Michigan:	\$ 48,781.25
Ypsilanti Township Treasurer:	\$124,547.06

TOTAL: \$177,126.81

**BUILDING DEPARTMENT REPORT
ALEX MAMO - CHIEF BUILDING OFFICIAL**

BUILDING DEPARTMENT MONTHLY REPORT - September 2015

Permit Type	Jan	Feb	Mar	April	May	June	July	Aug	Sept	Oct	Nov	Dec	TOTALS
Building	46	61	87	116	114	128	148	125	152				977
	\$ 3,081	\$ 9,211	\$ 20,850	\$ 16,030	\$ 13,320	\$ 23,326	\$ 19,613	\$ 35,654	\$ 34,430				\$ 175,515
Electrical	23	78	38	43	59	51	62	59	60				473
	\$ 1,530	\$ 4,715	\$ 2,775	\$ 3,375	\$ 4,090	\$ 3,525	\$ 4,975	\$ 3,910	\$ 4,305				\$ 33,200
Mechanical	78	89	119	101	130	155	69	107	117				965
	\$ 4,600	\$ 6,140	\$ 9,060	\$ 7,370	\$ 8,650	\$ 10,110	\$ 5,924	\$ 8,890	\$ 9,400				\$ 70,144
Plumbing	31	49	48	53	39	46	41	51	53				411
	\$ 1,625	\$ 2,830	\$ 3,775	\$ 4,825	\$ 2,605	\$ 3,445	\$ 3,695	\$ 4,660	\$ 4,095				\$ 31,555
Zoning	2	-	3	13	20	27	17	14	8				104
	\$ 90	\$ -	\$ 105	\$ 455	\$ 740	\$ 945	\$ 645	\$ 455	\$ 280				\$ 3,715
Sub Totals	180	277	295	326	362	407	337	356	390	-	-	-	2,930
TOTAL YTD	\$ 10,926	\$ 22,896	\$ 36,565	\$ 32,055	\$ 29,405	\$ 41,351	\$ 34,852	\$ 53,569	\$ 52,510	\$ -	\$ -	\$ -	\$ 314,129

BUILDING DEPARTMENT MONTHLY REPORT - 2014

Permit Type	Jan	Feb	Mar	April	May	June	July	Aug	Sept	Oct	Nov	Dec	TOTALS
Building	55	44	66	90	127	124	91	128	91	112	62	79	1,069
	\$ 16,244	\$ 16,632	\$ 12,783	\$ 18,614	\$ 96,726	\$ 56,621	\$ 12,936	\$ 17,586	\$ 16,583	\$ 20,770	\$ 14,954	\$ 17,582	\$ 318,031
Electrical	16	16	23	18	49	43	41	30	25	39	28	18	346
	\$ 1,290	\$ 2,175	\$ 1,815	\$ 1,800	\$ 3,855	\$ 2,775	\$ 3,465	\$ 2,670	\$ 2,250	\$ 2,820	\$ 2,325	\$ 1,290	\$ 28,530
Mechanical	85	51	50	58	81	98	75	35	59	96	80	66	834
	\$ 4,980	\$ 2,760	\$ 3,095	\$ 4,185	\$ 5,925	\$ 10,000	\$ 7,161	\$ 3,390	\$ 6,110	\$ 7,125	\$ 5,385	\$ 4,682	\$ 64,798
Plumbing	28	30	83	35	46	107	39	36	49	53	16	26	548
	\$ 2,145	\$ 2,010	\$ 4,545	\$ 2,745	\$ 3,525	\$ 6,300	\$ 2,955	\$ 2,430	\$ 3,885	\$ 3,780	\$ 1,080	\$ 1,905	\$ 37,305
Zoning	2	-	1	14	13	26	16	10	7	9	8	7	113
	\$ 90	\$ -	\$ 45	\$ 630	\$ 585	\$ 1,170	\$ 720	\$ 450	\$ 315	\$ 405	\$ 360	\$ 270	\$ 5,040
Sub Totals	186	141	223	215	316	398	262	239	231	309	194	196	2,910
TOTAL YTD	\$ 24,749	\$ 23,577	\$ 22,283	\$ 27,974	\$ 110,616	\$ 76,866	\$ 27,237	\$ 26,526	\$ 29,143	\$ 34,900	\$ 24,104	\$ 25,729	\$ 453,704

**BUILDING DEPARTMENT REPORT
ALEX MAMO - CHIEF BUILDING OFFICIAL**

INSPECTION RUNNING TOTALS													
Inspections	Jan	Feb	Mar	April	May	June	July	Aug	Sept	Oct	Nov	Dec	TOTALS
Total 2015	337	442	456	584	417	624	556	713	458				
Total 2014	318	253	354	417	429	501	581	496	445	516	360	344	5,014
Total 2013	336	328	239	306	445	404	389	507	459	647	410	378	4,848
Total 2012	852	259	592	328	340	268	275	419	317	382	340	276	4,648
Total 2011	319	238	280	311	371	369	319	411	349	432	316	143	3,858
Total 2010	292	220	361	366	379	358	427	405	350	449	322	140	4,069
Total 2009	323	315	340	337	350	372	440	401	463	374	341	137	4,193
Total 2008	460	352	326	432	432	628	727	562	533	577	393	128	5,550

Rental Inspections	Jan	Feb	Mar	April	May	June	July	Aug	Sept	Oct	Nov	Dec	TOTALS
Total 2015	327	287	361	339	297	318	286	287	354				
Total 2014	234	225	303	337	310	290	267	291	296	310	256	264	3,383
Total 2013	197	237	206	175	226	251	291	302	222	297	215	175	2,794
Total 2012	142	165	228	194	209	202	185	258	225	265	231	131	2,435
Total 2011	95	49	102	146	129	179	183	243	177	214	187	153	1,857
Total 2010	214	170	139	216	223	158	264	179	212	183	83	48	2,089
Total 2009	(Began tracking separate rental inspection totals Oct, 2009)									57	160	77	294



WASHTENAW COUNTY

OFFICE OF THE SHERIFF



JERRY L. CLAYTON
SHERIFF

2201 Hogback Road ♦ Ann Arbor, Michigan 48105-9732 ♦ OFFICE (734) 971-8400 ♦ FAX (734) 973-4624 ♦ EMAIL sheriff@ewashtenaw.org

MARK A. PTASZEK
UNDERSHERIFF

To: Brenda Stumbo, Ypsilanti Township Supervisor
From: Mike Marocco, Police Services Lieutenant
Cc: Mike Radzik, Ypsilanti Township Police Administrator & Ypsilanti Township Board
Marlene Radzik, WCSO Police Services Commander
Date: October 5, 2015
Re: September 2015 Police Services Monthly Report

In September of 2015, there were 3479 calls for service in Ypsilanti Township, which is a .75% increase in calls for service as compared to September of 2014.

OPERATIONS

September 2015 was the first month of the fall shift preference bid. The most significant change in the bid was the elimination of the (2) Neighborhood Enforcement Team positions which were changed to Traffic Enforcement positions. Operating While Under the Influence (Alcohol / Drugs) arrests moved from 6 (3 Self-initiated / 3 Crashes) in 2014 to 12 (9 Self-initiated / 3 Crashes) for 2015.

Our cases with the gang factions continue to move forward with many of the targeted individuals being either incarcerated or having warrants for their arrest. In addition, it appears that our efforts and disruption have resulted in the factions operating more frequently out of our jurisdiction. We have collaborated with Van Buren PD in reference to the uptick in activity in their jurisdiction. Information sharing and collaborative prosecution is on going.

Direct communication with Supervisor Stumbo and Director Radzik is open and ongoing. My cell phone number is 734-545-6684. Please feel free to call me directly with questions, comments or concerns.

PAROLE COMPLIANCE CHECKS

On September 22, 2015 the Community Action Team and the Ann Arbor Parole Office conducted (28) random parole checks around the Ypsilanti Twp. area. As a result of these compliance checks a total of 9 arrests were made. We continue to aggressively check parolee compliance in the Township through the use of sweeps and a close relationship with Parole and Probation. We now routinely assist Parole and Probation in acting on tips and accompany agents outside of the designated scheduled sweeps.

SEARCH WARRANTS

The following locations are where search warrants were executed by either the Community Action Team or LAWNET for narcotics:

- 900 Blk of Tyler by Postal Service, DEA and CAT
 - Over a kilo of MDMA (Exstasy) and cash were recovered.

TRAFFIC AND CRIME ENFORCEMENT



WASHTENAW COUNTY OFFICE OF THE SHERIFF



2201 Hogback Road ♦ Ann Arbor, Michigan 48105-9732 ♦ OFFICE (734) 971-8400 ♦ FAX (734) 973-4624 ♦ EMAIL sheriff@ewashtenaw.org

JERRY L. CLAYTON
SHERIFF

MARK A. PTASZEK
UNDERSHERIFF

The Sheriff's Office concluded the first phase of DDACTS in the (3) identified Zones. In summary, the new model had mixed results. While curbing both Property and Violent Crimes significantly within each zone, traffic crashes actually rose in 2 of the 3 target zones. One engineering issue was addressed that was/is leading to increases in crashes and we should see relief in the near future.

We have narrowed and adjusted our second phase target zones for the next 6 month period with input from the Patrolling deputies, Ypsilanti Township board, Crime analysis and Neighborhood Watch feedback. The next phase was implemented on October 1, 2015.

CLR-008 Monthly Summary Of Offenses (WD)

City:Ypsilanti Twp-YPT



Month:	September
Year:	2015
Print Option:	Print Both Monthly and YTD
Include Unfounded:	No
Report Offenses:	Include All (1,2,3,4)
Attempted/Completed/NA:	Includes Attempted, Completed
City:	Ypsilanti Twp-YPT

CLR-008 Monthly Summary Of Offenses (WD)

City:Ypsilanti Twp-YPT

For The Month Of September

Classification	Sep/2014	Sep/2015	%Change
09001 MURDER/NONNEGLIGENT MANSLAUGHTER (VOLUNTARY)	0	0	0%
09004 JUSTIFIABLE HOMICIDE	0	0	0%
10001 KIDNAPPING/ABDUCTION	1	0	-100%
10002 PARENTAL KIDNAPPING	0	0	0%
11001 SEXUAL PENETRATION PENIS/VAGINA -CSC 1ST DEGREE	0	1	0%
11002 SEXUAL PENETRATION PENIS/VAGINA -CSC 3RD DEGREE	2	0	-100%
11003 SEXUAL PENETRATION ORAL/ANAL -CSC 1ST DEGREE	1	0	-100%
11004 SEXUAL PENETRATION ORAL/ANAL -CSC 3RD DEGREE	0	0	0%
11006 SEXUAL PENETRATION OBJECT -CSC 3RD DEGREE	0	0	0%
11007 SEXUAL CONTACT FORCIBLE -CSC 2ND DEGREE	0	0	0%
11008 SEXUAL CONTACT FORCIBLE -CSC 4TH DEGREE	1	0	-100%
12000 ROBBERY	5	4	-20%
13001 NONAGGRAVATED ASSAULT	34	41	20.58%
13002 AGGRAVATED/FELONIOUS ASSAULT	13	15	15.38%
13003 INTIMIDATION/STALKING	7	1	-85.7%
20000 ARSON	2	1	-50%
21000 EXTORTION	0	0	0%
22001 BURGLARY -FORCED ENTRY	15	15	0%
22002 BURGLARY -ENTRY WITHOUT FORCE (Intent to Commit)	4	4	0%
23001 LARCENY -POCKETPICKING	0	0	0%
23002 LARCENY -PURSESNAATCHING	0	0	0%
23003 LARCENY -THEFT FROM BUILDING	14	9	-35.7%
23004 LARCENY -THEFT FROM COIN-OPERATED MACHINE/DEVICE	0	1	0%
23005 LARCENY -THEFT FROM MOTOR VEHICLE	21	20	-4.76%
23006 LARCENY -THEFT OF MOTOR VEHICLE PARTS/ACCESSORIES	3	3	0%
23007 LARCENY -OTHER	15	10	-33.3%
24001 MOTOR VEHICLE THEFT	10	6	-40%
24002 MOTOR VEHICLE, AS STOLEN PROPERTY	1	0	-100%
24003 MOTOR VEHICLE FRAUD	0	0	0%
25000 FORGERY/COUNTERFEITING	2	2	0%
26001 FRAUD -FALSE PRETENSE/SWINDLE/CONFIDENCE GAME	4	6	50%
26002 FRAUD -CREDIT CARD/AUTOMATIC TELLER MACHINE	6	4	-33.3%
26003 FRAUD -IMPERSONATION	3	5	66.66%
26005 FRAUD -WIRE FRAUD	0	0	0%
27000 EMBEZZLEMENT	0	1	0%
28000 STOLEN PROPERTY	3	0	-100%
29000 DAMAGE TO PROPERTY	35	37	5.714%
30001 RETAIL FRAUD -MISREPRESENTATION	2	0	-100%
30002 RETAIL FRAUD -THEFT	2	8	300%
30003 RETAIL FRAUD -REFUND/EXCHANGE	1	0	-100%
35001 VIOLATION OF CONTROLLED SUBSTANCE ACT	15	10	-33.3%
35002 NARCOTIC EQUIPMENT VIOLATIONS	7	6	-14.2%
37000 OBSCENITY	0	0	0%

CLR-008 Monthly Summary Of Offenses (WD)

City:Ypsilanti Twp-YPT

For The Month Of September

Classification	Sep/2014	Sep/2015	%Change
40001 COMMERCIALIZED SEX -PROSTITUTION	0	0	0%
40002 COMMERCIALIZED SEX -ASSISTING/PROMOTING PROSTITUTION	0	0	0%
52001 WEAPONS OFFENSE- CONCEALED	2	1	-50%
52003 WEAPONS OFFENSE -OTHER	0	2	0%
Group A Totals	231	213	-7.79%
22003 BURGLARY - UNLAWFUL ENTRY (NO INTENT)	0	0	0%
22004 POSSESSION OF BURGLARY TOOLS	1	0	-100%
26006 FRAUD -BAD CHECKS	0	1	0%
36004 SEX OFFENSE -OTHER	0	0	0%
38001 FAMILY -ABUSE/NEGLECT NONVIOLENT	1	4	300%
41002 LIQUOR VIOLATIONS -OTHER	1	2	100%
48000 OBSTRUCTING POLICE	6	8	33.33%
49000 ESCAPE/FLIGHT	1	0	-100%
50000 OBSTRUCTING JUSTICE	12	9	-25%
53001 DISORDERLY CONDUCT	3	4	33.33%
53002 PUBLIC PEACE -OTHER	0	0	0%
54001 HIT and RUN MOTOR VEHICLE ACCIDENT	1	1	0%
54002 OPERATING UNDER THE INFLUENCE OF LIQUOR OR DRUGS	6	12	100%
55000 HEALTH AND SAFETY	2	1	-50%
56000 CIVIL RIGHTS	0	0	0%
57001 TRESPASS	1	0	-100%
57002 INVASION OF PRIVACY -OTHER	0	0	0%
58000 SMUGGLING	0	0	0%
62000 CONSERVATION	0	1	0%
63000 VAGRANCY	0	0	0%
70000 JUVENILE RUNAWAY	4	7	75%
73000 MISCELLANEOUS CRIMINAL OFFENSE	0	1	0%
77000 CONSPIRACY (ALL CRIMES)	0	0	0%
Group B Totals	39	51	30.76%
2800 JUVENILE OFFENSES AND COMPLAINTS	71	53	-25.3%
2900 TRAFFIC OFFENSES	28	22	-21.4%
3000 WARRANTS	57	51	-10.5%
3100 TRAFFIC CRASHES	96	99	3.125%
3200 SICK / INJURY COMPLAINT	55	103	87.27%
3300 MISCELLANEOUS COMPLAINTS	798	848	6.265%
3400 WATERCRAFT COMPLAINTS / ACCIDENTS	2	0	-100%
3500 NON-CRIMINAL COMPLAINTS	797	884	10.91%
3700 MISCELLANEOUS TRAFFIC COMPLAINTS	805	687	-14.6%
3800 ANIMAL COMPLAINTS	89	61	-31.4%
3900 ALARMS	176	160	-9.09%
Group C Totals	2974	2968	-0.20%
4000 HAZARDOUS TRAFFIC CITATIONS / WARNINGS	0	0	0%

CLR-008 Monthly Summary Of Offenses (WD)

City:Ypsilanti Twp-YPT

For The Month Of September

Classification	Sep/2014	Sep/2015	%Change
4100 NON-HAZARDOUS TRAFFIC CITATIONS / WARNINGS	0	0	0%
4200 PARKING CITATIONS	11	4	-63.6%
4300 LICENSE / TITLE / REGISTRATION CITATIONS	0	0	0%
4500 MISCELLANEOUS A THROUGH UUUU	8	9	12.5%
Group D Totals	19	13	-31.5%
5000 FIRE CLASSIFICATIONS	0	1	0%
5100 18A STATE CODE FIRE CLASSIFICATIONS	0	0	0%
Group E Totals	0	1	0%
6000 MISCELLANEOUS ACTIVITIES (6000)	30	27	-10%
6100 MISCELLANEOUS ACTIVITIES (6100)	102	151	48.03%
6300 CANINE ACTIVITIES	5	3	-40%
6500 CRIME PREVENTION ACTIVITIES	35	49	40%
6600 COURT / WARRANT ACTIVITIES	3	1	-66.6%
6700 INVESTIGATIVE ACTIVITIES	15	2	-86.6%
Group F Totals	190	233	22.63%
City : Ypsilanti Twp Totals	3453	3479	0.752%

CLR-008 Monthly Summary Of Offenses (WD)

City:Ypsilanti Twp-YPT

Year To Date Through September

Classification	2014	2015	%Change
Group F Totals	0	0	0%
09001 MURDER/NONNEGLIGENT MANSLAUGHTER (VOLUNTARY)	2	0	-100%
09004 JUSTIFIABLE HOMICIDE	1	0	-100%
10001 KIDNAPPING/ABDUCTION	5	3	-40%
10002 PARENTAL KIDNAPPING	1	3	200%
11001 SEXUAL PENETRATION PENIS/VAGINA -CSC 1ST DEGREE	14	20	42.85%
11002 SEXUAL PENETRATION PENIS/VAGINA -CSC 3RD DEGREE	5	6	20%
11003 SEXUAL PENETRATION ORAL/ANAL -CSC 1ST DEGREE	4	1	-75%
11004 SEXUAL PENETRATION ORAL/ANAL -CSC 3RD DEGREE	5	3	-40%
11006 SEXUAL PENETRATION OBJECT -CSC 3RD DEGREE	0	1	0%
11007 SEXUAL CONTACT FORCIBLE -CSC 2ND DEGREE	10	3	-70%
11008 SEXUAL CONTACT FORCIBLE -CSC 4TH DEGREE	4	6	50%
12000 ROBBERY	45	36	-20%
13001 NONAGGRAVATED ASSAULT	320	358	11.87%
13002 AGGRAVATED/FELONIOUS ASSAULT	149	171	14.76%
13003 INTIMIDATION/STALKING	32	22	-31.2%
20000 ARSON	7	4	-42.8%
21000 EXTORTION	1	1	0%
22001 BURGLARY -FORCED ENTRY	201	151	-24.8%
22002 BURGLARY -ENTRY WITHOUT FORCE (Intent to Commit)	39	34	-12.8%
23001 LARCENY -POCKETPICKING	4	0	-100%
23002 LARCENY -PURSESNAATCHING	4	1	-75%
23003 LARCENY -THEFT FROM BUILDING	151	101	-33.1%
23004 LARCENY -THEFT FROM COIN-OPERATED MACHINE/DEVICE	2	2	0%
23005 LARCENY -THEFT FROM MOTOR VEHICLE	138	137	-0.72%
23006 LARCENY -THEFT OF MOTOR VEHICLE PARTS/ACCESSORIES	29	22	-24.1%
23007 LARCENY -OTHER	89	91	2.247%
24001 MOTOR VEHICLE THEFT	89	70	-21.3%
24002 MOTOR VEHICLE, AS STOLEN PROPERTY	11	7	-36.3%
24003 MOTOR VEHICLE FRAUD	1	1	0%
25000 FORGERY/COUNTERFEITING	15	17	13.33%
26001 FRAUD -FALSE PRETENSE/SWINDLE/CONFIDENCE GAME	59	60	1.694%
26002 FRAUD -CREDIT CARD/AUTOMATIC TELLER MACHINE	46	52	13.04%
26003 FRAUD -IMPERSONATION	43	62	44.18%
26005 FRAUD -WIRE FRAUD	3	4	33.33%
27000 EMBEZZLEMENT	7	10	42.85%
28000 STOLEN PROPERTY	22	14	-36.3%
29000 DAMAGE TO PROPERTY	279	280	0.358%
30001 RETAIL FRAUD -MISREPRESENTATION	6	6	0%
30002 RETAIL FRAUD -THEFT	56	71	26.78%
30003 RETAIL FRAUD -REFUND/EXCHANGE	2	1	-50%
35001 VIOLATION OF CONTROLLED SUBSTANCE ACT	143	114	-20.2%
35002 NARCOTIC EQUIPMENT VIOLATIONS	62	39	-37.0%

CLR-008 Monthly Summary Of Offenses (WD)

City:Ypsilanti Twp-YPT

Year To Date Through September

Classification	2014	2015	%Change
37000 OBSCENITY	5	1	-80%
40001 COMMERCIALIZED SEX -PROSTITUTION	5	0	-100%
40002 COMMERCIALIZED SEX -ASSISTING/PROMOTING PROSTITUTION	7	0	-100%
52001 WEAPONS OFFENSE- CONCEALED	21	17	-19.0%
52003 WEAPONS OFFENSE -OTHER	8	11	37.5%
Group A Totals	2152	2014	-6.41%
22003 BURGLARY - UNLAWFUL ENTRY (NO INTENT)	10	3	-70%
22004 POSSESSION OF BURGLARY TOOLS	1	0	-100%
26006 FRAUD -BAD CHECKS	15	6	-60%
36004 SEX OFFENSE -OTHER	4	2	-50%
38001 FAMILY -ABUSE/NEGLECT NONVIOLENT	39	23	-41.0%
41002 LIQUOR VIOLATIONS -OTHER	16	16	0%
48000 OBSTRUCTING POLICE	62	58	-6.45%
49000 ESCAPE/FLIGHT	6	5	-16.6%
50000 OBSTRUCTING JUSTICE	107	84	-21.4%
53001 DISORDERLY CONDUCT	32	32	0%
53002 PUBLIC PEACE -OTHER	2	1	-50%
54001 HIT and RUN MOTOR VEHICLE ACCIDENT	6	8	33.33%
54002 OPERATING UNDER THE INFLUENCE OF LIQUOR OR DRUGS	70	90	28.57%
55000 HEALTH AND SAFETY	12	19	58.33%
56000 CIVIL RIGHTS	1	0	-100%
57001 TRESPASS	3	8	166.6%
57002 INVASION OF PRIVACY -OTHER	1	0	-100%
58000 SMUGGLING	3	3	0%
62000 CONSERVATION	0	2	0%
63000 VAGRANCY	4	4	0%
70000 JUVENILE RUNAWAY	76	80	5.263%
73000 MISCELLANEOUS CRIMINAL OFFENSE	7	19	171.4%
77000 CONSPIRACY (ALL CRIMES)	1	1	0%
Group B Totals	478	464	-2.92%
2800 JUVENILE OFFENSES AND COMPLAINTS	521	557	6.909%
2900 TRAFFIC OFFENSES	330	278	-15.7%
3000 WARRANTS	573	463	-19.1%
3100 TRAFFIC CRASHES	997	964	-3.30%
3200 SICK / INJURY COMPLAINT	594	807	35.85%
3300 MISCELLANEOUS COMPLAINTS	7116	7141	0.351%
3400 WATERCRAFT COMPLAINTS / ACCIDENTS	19	15	-21.0%
3500 NON-CRIMINAL COMPLAINTS	7739	8260	6.732%
3700 MISCELLANEOUS TRAFFIC COMPLAINTS	9035	7945	-12.0%
3800 ANIMAL COMPLAINTS	774	666	-13.9%
3900 ALARMS	1668	1633	-2.09%
Group C Totals	29366	28729	-2.16%

CLR-008 Monthly Summary Of Offenses (WD)

City:Ypsilanti Twp-YPT

Year To Date Through September

Classification	2014	2015	%Change
4000 HAZARDOUS TRAFFIC CITATIONS / WARNINGS	5	9	80%
4100 NON-HAZARDOUS TRAFFIC CITATIONS / WARNINGS	2	0	-100%
4200 PARKING CITATIONS	48	34	-29.1%
4300 LICENSE / TITLE / REGISTRATION CITATIONS	3	7	133.3%
4500 MISCELLANEOUS A THROUGH UUUU	73	82	12.32%
Group D Totals	131	132	0.763%
5000 FIRE CLASSIFICATIONS	2	4	100%
5100 18A STATE CODE FIRE CLASSIFICATIONS	18	3	-83.3%
Group E Totals	20	7	-65%
6000 MISCELLANEOUS ACTIVITIES (6000)	296	279	-5.74%
6100 MISCELLANEOUS ACTIVITIES (6100)	830	1035	24.69%
6300 CANINE ACTIVITIES	47	42	-10.6%
6500 CRIME PREVENTION ACTIVITIES	270	322	19.25%
6600 COURT / WARRANT ACTIVITIES	19	9	-52.6%
6700 INVESTIGATIVE ACTIVITIES	63	54	-14.2%
Group F Totals	1525	1741	14.16%
City : Ypsilanti Twp Totals	33672	33087	-1.73%

YPSILANTI TOWNSHIP FIRE DEPARTMENT
MONTHLY REPORT

AUGUST 2015

Fire Department staffing levels are as follows:

1 Fire Chief	3 Shift Captains	20 Fire Fighters
1 Fire Marshal (part time)	3 Shift Lieutenants	1 Clerk III / Staff Support

All fire department response personnel are licensed as Emergency Medical Technicians by the State of Michigan Public Health. During the month, the fire department responded to 379 requests for assistance. Of those requests, 247 were medical emergency service calls, with the remaining 132 incidents classified as non-medical and/or fire related.

Department activities for the month of August, 2015:

- 1) The Public Education Department participated in the following events:
 - a) Homefront Victory Parade
 - b) Truck Demonstration & Fire Prevention at Christian Tabernacle Church
 - c) Smoke Alarms: 619 Kennedy (2)
 - d) Car Seat fittings for U of M Buckle Up program

- 2) Fire fighters attended 5 neighborhood watch meetings

- 3) Fire fighters received training in the following areas:
 - a) Washtenaw County Tech Rescue Team
 - b) Washtenaw County HazMat Team
 - c) EMS
 - d) St Joseph Hospital with Superior Township & Ypsilanti City Fire Departments
 - e) Hurst Vehicle Extrication

The Fire Marshal had these inspections / meetings for the month of August, 2015:
(the Fire Marshal part-time contract ended August 19th, per Civil Service rules)

- 1) Plan Reviews: 5
- 2) Inspections: 2
- 3) Complaint investigations: 1
- 4) Court Reviews: 1
- 5) Code Enforcements: 2
- 6) Fire Alarm testings: 1
- 7) Consultations: 1
- 8) Fire Investigations: 3 – 823 E Michigan (2) & 287 Kansas (1)
- 9) Commercial Building meetings: 2
- 10) Insurance Company meeting: 1
- 11) Building Department meetings: 2
- 12) Human Resources meeting: 1
- 13) Completed reports

The Fire Chief attended these meetings / events for the month of August, 2015:

- 1) Stuff the Bus campaign with United Way & Washtenaw County Parks
- 2) WAMAA picnic in Dexter
- 3) SE Michigan Fire Chiefs meeting
- 4) Fire Rescue International conference in Atlanta, GA
- 5) 4 Heritage Walk Parade construction meetings
- 6) Participated in the Heritage Walk Parade
- 7) Training Budget review with Training Officer
- 8) 2016 Draft Budget meeting
- 9) AFG Grant Consortium meeting
- 10) Department Head meeting
- 11) Development Team meeting
- 12) Conference with Human Resources & Township Attorney
- 13) 800 MHz Consortium meeting
- 14) Met with Graphics Company regarding new Fire Truck
- 15) Emergency Response Plan meeting with YCUA
- 16) Meeting with 2 Board Up vendors
- 17) Utilized a Community Service worker for 50.5 hours

There were 0 injuries and 0 deaths reported this month for civilians.

There was 0 injuries and 0 deaths reported this month for fire fighters.

This month the total fire loss, including vehicle fires, is estimated at **\$28,500.00**. All occurred at the following locations:

DATE OF LOSS	ADDRESS	ESTIMATED LOSS
1) 08/02/2015	1824 Eileen	\$ 0.00 (brush)
2) 08/03/2015	6655 Crane	\$ 0.00 (Mutual Aid-Pittsfield Twp)
3) 08/04/2015	2531 Ellsworth	\$ 1,000.00 (cooking)
4) 08/04/2015	1500 Village Lane	\$ 0.00 (dumpster)
5) 08/05/2015	814 E Cross	\$ 17,000.00 (building)
6) 08/11/2015	115 Holmes	\$ 0.00 (forest / woods)
7) 08/13/2015	2630 Woodruff Lane	\$ 0.00 (vehicle)
8) 08/19/2015	287 Kansas	\$ 6,000.00 (vehicle)
9) 08/21/2015	329 Jarvis	\$ 0.00 (Mutual Aid-Ypsi City)
10) 08/22/2015	953 Washtenaw	\$ 0.00 (Mutual Aid-Ypsi City)
11) 08/24/2015	William @ Emerson	\$ 0.00 (outside rubbish)
12) 08/24/2015	1222 Marcus	\$ 0.00 (outside rubbish)
13) 08/24/2015	3344 S Grove	\$ 0.00 (outside rubbish)
14) 08/26/2015	Johnson @ George Place	\$ 0.00 (outside rubbish)
15) 08/27/2015	2625 Tyler	\$ 4,500.00 (vehicle)
16) 08/28/2015	2721 Int'l Drive #1606B	\$ 0.00 (building – cooking)

Respectfully submitted,

Rhonda Bates, Clerical Support Staff
Charter Township of Ypsilanti Fire Department

Attachment: Fire House Incident Type Report (Summary) 08/01/2015 – 08/31/2015

Ypsilanti Township Fire Department

Incident Type Report (Summary)

Alarm Date Between {08/01/15} And {08/31/15}

Incident Type	Count	Pct of Incidents	Total Est Loss	Pct of Losses
1 Fire				
111 Building fire	6	1.58%	\$17,000	59.64%
113 Cooking fire, confined to container	1	0.26%	\$1,000	3.50%
131 Passenger vehicle fire	3	0.79%	\$10,500	36.84%
141 Forest, woods or wildland fire	1	0.26%	\$0	0.00%
142 Brush or brush-and-grass mixture fire	1	0.26%	\$0	0.00%
150 Outside rubbish fire, Other	3	0.79%	\$0	0.00%
151 Outside rubbish, trash or waste fire	1	0.26%	\$0	0.00%
154 Dumpster or other outside trash receptacle fire	1	0.26%	\$0	0.00%
	17	4.49%	\$28,500	100.00%
3 Rescue & Emergency Medical Service Incident				
300 Rescue, EMS incident, other	25	6.60%	\$0	0.00%
311 Medical assist, assist EMS crew	20	5.28%	\$0	0.00%
320 Emergency medical service, other	10	2.64%	\$0	0.00%
321 EMS call, excluding vehicle accident with injury	68	44.33%	\$0	0.00%
322 Motor vehicle accident with injuries	14	3.69%	\$0	0.00%
323 Motor vehicle/pedestrian accident (MV Ped)	4	1.06%	\$0	0.00%
324 Motor Vehicle Accident with no injuries	6	1.58%	\$0	0.00%
	247	65.17%	\$0	0.00%
4 Hazardous Condition (No Fire)				
412 Gas leak (natural gas or LPG)	1	0.26%	\$0	0.00%
424 Carbon monoxide incident	2	0.53%	\$0	0.00%
440 Electrical wiring/equipment problem, Other	4	1.06%	\$0	0.00%
442 Overheated motor	1	0.26%	\$0	0.00%
444 Power line down	4	1.06%	\$0	0.00%
445 Arcing, shorted electrical equipment	2	0.53%	\$0	0.00%
463 Vehicle accident, general cleanup	1	0.26%	\$0	0.00%
	15	3.96%	\$0	0.00%
5 Service Call				
500 Service Call, other	1	0.26%	\$0	0.00%
5111 Lock-in	1	0.26%	\$0	0.00%
522 Water or steam leak	1	0.26%	\$0	0.00%
531 Smoke or odor removal	7	1.85%	\$0	0.00%
542 Animal rescue	1	0.26%	\$0	0.00%
550 Public service assistance, Other	1	0.26%	\$0	0.00%
5501 Neighborhood Watch	5	1.32%	\$0	0.00%
552 Police matter	1	0.26%	\$0	0.00%
553 Public service	1	0.26%	\$0	0.00%

Ypsilanti Township Fire Department

Incident Type Report (Summary)

Alarm Date Between {08/01/15} And {08/31/15}

Incident Type	Count	Pct of Incidents	Total Est Loss	Pct of Losses
5 Service Call				
554 Assist invalid	1	0.26%	\$0	0.00%
561 Unauthorized burning	6	1.58%	\$0	0.00%
	26	6.86%	\$0	0.00%
6 Good Intent Call				
600 Good intent call, Other	6	1.58%	\$0	0.00%
611 Dispatched & cancelled en route	19	5.01%	\$0	0.00%
6111 Canceled on Arrival	7	1.85%	\$0	0.00%
621 Wrong location	1	0.26%	\$0	0.00%
622 No Incident found on arrival at dispatch address	6	1.58%	\$0	0.00%
631 Authorized controlled burning	3	0.79%	\$0	0.00%
	42	11.08%	\$0	0.00%
7 False Alarm & False Call				
700 False alarm or false call, Other	3	0.79%	\$0	0.00%
715 Local alarm system, malicious false alarm	2	0.53%	\$0	0.00%
730 System malfunction, Other	1	0.26%	\$0	0.00%
733 Smoke detector activation due to malfunction	4	1.06%	\$0	0.00%
735 Alarm system sounded due to malfunction	4	1.06%	\$0	0.00%
736 CO detector activation due to malfunction	2	0.53%	\$0	0.00%
740 Unintentional transmission of alarm, Other	2	0.53%	\$0	0.00%
741 Sprinkler activation, no fire - unintentional	2	0.53%	\$0	0.00%
743 Smoke detector activation, no fire - unintentional	5	1.32%	\$0	0.00%
744 Detector activation, no fire - unintentional	2	0.53%	\$0	0.00%
745 Alarm system activation, no fire - unintentional	1	0.26%	\$0	0.00%
746 Carbon monoxide detector activation, no CO	3	0.79%	\$0	0.00%
	31	8.18%	\$0	0.00%
9 Special Incident Type				
900 Special type of incident, Other	1	0.26%	\$0	0.00%
	1	0.26%	\$0	0.00%
Total Incident Count:	379		Total Est Loss:	\$28,500

YPSILANTI TOWNSHIP FIRE DEPARTMENT
MONTHLY REPORT

SEPTEMBER 2015

Fire Department staffing levels are as follows:

1 Fire Chief	3 Shift Captains	20 Fire Fighters
	3 Shift Lieutenants	1 Clerk III / Staff Support

All fire department response personnel are licensed as Emergency Medical Technicians by the State of Michigan Public Health. During the month, the fire department responded to 377 requests for assistance. Of those requests, 266 were medical emergency service calls, with the remaining 111 incidents classified as non-medical and/or fire related.

Department activities for the month of September, 2015:

- 1) The Public Education Department participated in the following events:
 - a) 9/11 Luncheon & Ceremony at Ypsilanti Township Senior Center
 - b) Patriot Day Commemoration at Ypsilanti American Legion
 - c) Truck Demonstration at Streamwood Subdivision Neighborhood picnic
 - d) Truck Demonstration at National Guard Armory Family Day
 - e) Truck Demonstration & Fire Safety Talk at K C Daycare
 - f) Smoke Alarms: 5892 Willowbridge (2)
 - g) Car Seat fittings for U of M Buckle Up program

- 2) Fire fighters attended 11 neighborhood watch meetings

- 3) Fire fighters received training in the following areas:
 - a) Washtenaw County Tech Rescue Team
 - b) Washtenaw County HazMat Team
 - c) Pump Training at Rave Theater with Pittsfield Township Fire Department

The Fire Chief attended these meetings / events for the month of September, 2015:

- 1) WAMAA meeting
- 2) IFC 2012 review for Township Board
- 3) 2 meetings with Township Attorney
- 4) Fire Investigation & follow up for 839 Tyler
- 5) Completed Addressing for Creekside West subdivision
- 6) Attended 9/11 Luncheon
- 7) SE Michigan Fire Chiefs meeting
- 8) Officers meeting
- 9) Issued 2 Burn Permits
- 10) Pre-bid meeting for Roof Replacement project
- 11) Inspection at Clark East Towers
- 12) Graphics meeting for new Fire Truck
- 13) New Fire Truck final meeting in Charlotte
- 14) Fire Investigation for 552 N Harris
- 15) 2 meetings with Firefighter Union
- 16) MI Fire Inspectors Fall Conference in Lansing
- 17) AFG Training Simulator meeting
- 18) Bid Opening for AFG Simulator in Ann Arbor
- 19) Several meetings with HR & Township Attorney
- 20) Processed 1 Knox Box application
- 21) Completed 2 Site Inspections

There was 0 injuries and 0 deaths reported this month for civilians.

There was 0 injuries and 0 deaths reports this month for fire fighters.

This month the total fire loss, including vehicle fires, is estimated at **\$124,000.00**. All occurred at the following locations:

DATE OF LOSS	ADDRESS	ESTIMATED LOSS
1) 09/02/2015	2380 Carpenter	\$ 0.00 (Mutual Aid-Pittsfield Twp)
2) 09/06/2015	7661 Berwick Drive	\$ 0.00 (cooking)
3) 09/07/2015	2911 Bynan Drive	\$ 0.00 (outside rubbish)
4) 09/08/2015	839 Tyler	\$ 20,000.00 (building)
5) 09/08/2015	632 Glenwood	\$ 1,800.00 (vehicle)
6) 09/09/2015	2324 Woodchip	\$ 0.00 (Mutual Aid-Pittsfield Twp)
7) 09/17/2015	810 Eugene	\$ 1,500.00 (building)
8) 09/17/2015	810 Eugene-exp #1	\$ 23,000.00 (building)
9) 09/17/2015	820 Eugene-exp #2	\$ 1,000.00 (building)
10) 09/20/2015	1423 Andrea	\$ 0.00 (outside rubbish)
11) 09/20/2015	2351 Ellsworth	\$ 0.00 (fire / other)
12) 09/21/2015	1017 Cross	\$ 0.00 (Mutual Aid-Ypsi City)
13) 09/25/2015	1314 E Forest	\$ 1,700.00 (vehicle)
14) 09/28/2015	8956 MacArthur	\$ 0.00 (Mutual Aid-Superior Twp)
15) 09/30/2015	552 N Harris	\$ 75,000.00 (building)

Respectfully submitted,

Rhonda Bates, Clerical Support Staff
Charter Township of Ypsilanti Fire Department

Attachment: Fire House Incident Type Report (Summary) 09/01/2015 – 09/30/2015

Ypsilanti Township Fire Department

Incident Type Report (Summary)

Alarm Date Between {09/01/15} And {09/30/15}

Incident Type	Count	Pct of Incidents	Total Est Loss	Pct of Losses
1 Fire				
100 Fire, Other	1	0.27%	\$0	0.00%
111 Building fire	9	2.39%	\$120,500	97.17%
113 Cooking fire, confined to container	1	0.27%	\$0	0.00%
131 Passenger vehicle fire	2	0.53%	\$3,500	2.82%
151 Outside rubbish, trash or waste fire	2	0.53%	\$0	0.00%
	15	3.98%	\$124,000	100.00%
2 Overpressure Rupture, Explosion, Overheat(no fire)				
240 Explosion (no fire), Other	1	0.27%	\$0	0.00%
	1	0.27%	\$0	0.00%
3 Rescue & Emergency Medical Service Incident				
300 Rescue, EMS incident, other	42	11.14%	\$0	0.00%
311 Medical assist, assist EMS crew	25	6.63%	\$0	0.00%
320 Emergency medical service, other	10	2.65%	\$0	0.00%
321 EMS call, excluding vehicle accident with injury	65	43.77%	\$0	0.00%
322 Motor vehicle accident with injuries	6	1.59%	\$0	0.00%
324 Motor Vehicle Accident with no injuries	16	4.24%	\$0	0.00%
331 Lock-in (if lock out , use 511)	1	0.27%	\$0	0.00%
356 High-angle rescue	1	0.27%	\$0	0.00%
	266	70.56%	\$0	0.00%
4 Hazardous Condition (No Fire)				
411 Gasoline or other flammable liquid spill	2	0.53%	\$0	0.00%
412 Gas leak (natural gas or LPG)	1	0.27%	\$0	0.00%
424 Carbon monoxide incident	1	0.27%	\$0	0.00%
444 Power line down	3	0.80%	\$0	0.00%
445 Arcing, shorted electrical equipment	2	0.53%	\$0	0.00%
463 Vehicle accident, general cleanup	1	0.27%	\$0	0.00%
	10	2.65%	\$0	0.00%
5 Service Call				
500 Service Call, other	2	0.53%	\$0	0.00%
510 Person in distress, Other	1	0.27%	\$0	0.00%
511 Lock-out	1	0.27%	\$0	0.00%
531 Smoke or odor removal	6	1.59%	\$0	0.00%
5501 Neighborhood Watch	10	2.65%	\$0	0.00%
5502 Community Outreach	3	0.80%	\$0	0.00%

Ypsilanti Township Fire Department

Incident Type Report (Summary)

Alarm Date Between {09/01/15} And {09/30/15}

Incident Type	Count	Pct of Incidents	Total Est Loss	Pct of Losses
5 Service Call				
553 Public service	2	0.53%	\$0	0.00%
554 Assist invalid	1	0.27%	\$0	0.00%
561 Unauthorized burning	3	0.80%	\$0	0.00%
	29	7.69%	\$0	0.00%
6 Good Intent Call				
600 Good intent call, Other	1	0.27%	\$0	0.00%
611 Dispatched & cancelled en route	28	7.43%	\$0	0.00%
6111 Canceled on Arrival	12	3.18%	\$0	0.00%
622 No Incident found on arrival at dispatch address	2	0.53%	\$0	0.00%
650 Steam, Other gas mistaken for smoke, Other	1	0.27%	\$0	0.00%
671 HazMat release investigation w/no HazMat	1	0.27%	\$0	0.00%
	45	11.94%	\$0	0.00%
7 False Alarm & False Call				
700 False alarm or false call, Other	2	0.53%	\$0	0.00%
730 System malfunction, Other	1	0.27%	\$0	0.00%
733 Smoke detector activation due to malfunction	3	0.80%	\$0	0.00%
736 CO detector activation due to malfunction	1	0.27%	\$0	0.00%
743 Smoke detector activation, no fire - unintentional	1	0.27%	\$0	0.00%
744 Detector activation, no fire - unintentional	2	0.53%	\$0	0.00%
745 Alarm system activation, no fire - unintentional	1	0.27%	\$0	0.00%
	11	2.92%	\$0	0.00%

Total Incident Count: 377

Total Est Loss:

\$124,000



Charter Township of Ypsilanti

7200 S. HURON RIVER DRIVE • YPSILANTI, MI 48197

SUPERVISOR BRENDA STUMBO • CLERK KAREN LOVEJOY ROE • TREASURER LARRY DOE
TRUSTEES: JEAN HALL CURRIE • STAN ELDRIDGE • MIKE MARTIN • SCOTT MARTIN

WORK SESSION AGENDA CHARTER TOWNSHIP OF YPSILANTI TUESDAY, OCTOBER 20, 2015

5:00 P.M.

**CIVIC CENTER
BOARD ROOM
7200 S. HURON RIVER DRIVE**

1. SPLASH PAD LONNIE SCOTT, PARK COMMISSION
2. 2016 PRELIMINARY BUDGET SUPERVISOR STUMBO AND JAVONNA NEEL
 - a) 101 - GENERAL FUND
 - b) 206 – FIRE
 - c) 208 – PARKS
 - d) 212 – BSR II
 - e) 226 – ENVIRONMENTAL SERVICES
 - f) 230 – RECREATION
3. DEDICATION OF CIVIC CENTER AND 14B COURT TRUSTEE SCOTT MARTIN
4. AGENDA REVIEW SUPERVISOR STUMBO
5. OTHER DISCUSSION BOARD MEMBERS

Park Commission

7200 S. Huron River Drive
Ypsilanti, MI 48197
Phone: (734) 484-0073
Fax: (734) 544-3501
www.ytown.org



Lonnie Scott, Chair
Keith P. Jason, Vice Chair
Debbie Swanson, Secretary
Richard Roe, Treasurer

Commissioners:
Gail Boyd-Palmer
Evan Hayes
Jimmie Maggard
Monica Ross-Williams
Jasmine Mackey

MEMORANDUM

To: Brenda Stumbo, Supervisor
Karen Lovejoy Roe, Clerk
Larry Doe, Treasurer
Ypsilanti Township Board of Trustees

From: Lonnie Scott, Chair of the Ypsilanti Township Park Commission

Subject: Recommendations to the Township Board

Date: October 6, 2015

At our meeting on October 5, 2015, the Park Commission voted unanimously in favor of the following motion:

“The Park Commission recommends that the Township Board review the conceptual splash pad design from Vortex. We further recommend that financing options be pursued to allow for a complete installation of the splash pad. Finally, it is recommended that a joint committee be created to consist of park commissioners and board members to move the project forward.”

This recommendation comes after months of planning and discussion about the project and is the next step needed to move forward. We look forward to working with the Township Board to advance this project.

The proposal may be found in digital format here:
<https://vortex.paperlessproposal.com/v/85643/2728/120410>

Please let me know if you have any questions.



PROPOSAL

**A CLEAR
SOURCE
OF
FUN**

**Ypsilanti Splashpad
Charter Township of Ypsilanti - Parks &
Recreation**

July 2, 2015





Ypsilanti Splashpad

Charter Township of Ypsilanti - Parks & Recreation

Ypsilanti, MI

After carefully assessing your needs, we have designed a Splashpad solution specifically for your project. Please see the attached 3D renderings for visual support as well as the Top View drawing giving you dimensions, water flows and layout of the products selected for you. A CAD version of the Spray Zone is available upon request. You will also find a short summary of each product selected within this proposal for a better understanding of the individual features we are proposing.

The Water Management System proposed is a full recirculation system that includes a manifold, solenoid valves, a full filtration system, a chemical controller and a wireless controller that allows access to the system from anywhere.

We have designed a Splashpad comprised of above ground spray features and ground sprays for maximum play value.

Play Value

Vortex Aquatic Structures International Inc. designs every Splashpad with a variety of water effects to ensure the maximum play value for the users. Emphasis is put on interactive play and narration throughout the Splashpad. The goal is to stimulate imagination and creativity, unscripted free play encourages children to create their own play experiences. Our products are designed with the Universal Design principal at its core. This results in an esthetically pleasing design that can be enjoyed by users of all ages and ability. Our exclusive Vortex Technologies encourage interactivity and allow users to control the water and the feature itself.

Quality and Durability

Our products are made of stainless steel and we utilize some of the most durable materials in the industry; including our unique Seeflow material, our Soft-touch elastomer as well as lead-free brass nozzles for maximum durability. Our components are vandal resistant as well as being UV and chemical resistant. We create products that are safe, durable and of the highest quality ensuring your Splashpad will endure season after season of use.

We have Experience

Vortex Aquatic Structures International Inc. is the world leader in Aquatic Play Landscapes and entertainment. With installations at more than 6,000 locations around the world in public, commercial and entertainment settings, Vortex International provides imaginative, durable aquatic play and water feature solutions that create everlasting memories. Our ongoing mission is to develop fun, safe and reliable products for families and children of all ages and abilities.

We have included a short corporate video to familiarize you with Vortex Aquatic Structures International Inc. Please feel free to consult our reference list and contact us if you have any questions or need assistance.

Thank you and enjoy our proposal

**A CLEAR
SOURCE
OF
POSSIBILITIES**



VORTEX

**A CLEAR
SOURCE
OF
FUN**

CELEBRATING

20
YEARS

OF AQUATIC PLAY
INNOVATION

1995-2015

INDUSTRY DESIGN LEADERS



Vortex's aquatic play solutions continue to be recognized by the prestigious **DREAM DESIGN AWARDS**, awarded by Aquatics International, the leading media network in the industry.

2013

- + THE RAY AND JOAN KROC CORPS COMMUNITY CENTER
- + NACPRO AWARD — BLUE HERON BAY

2012

- + CUMMING AQUATIC CENTER
- + GRAND PRAIRIE AQUATICS AND MULTIPLEX
- + SKIATOOK CENTRAL PARK SPLASHPAD®
- + STEPHEN SORENSEN PARK

2011

- + BENTLEY PARK SPLASHPAD®
- + KROC CENTER
- + MACDONALD ISLAND PARK

2010

- + KIDS LOVE RECREATION SPLASHPAD®
- + CRYSTAL BEACH AQUATIC CENTER
- + CITRUS COMMUNITY PARK SPLASHPAD®

2009

- + JEFFERSON, MCKINLEY AND SOUTH PARK
- + OHELLO COMMUNITY POOL

OUR DESIGN PHILOSOPHY

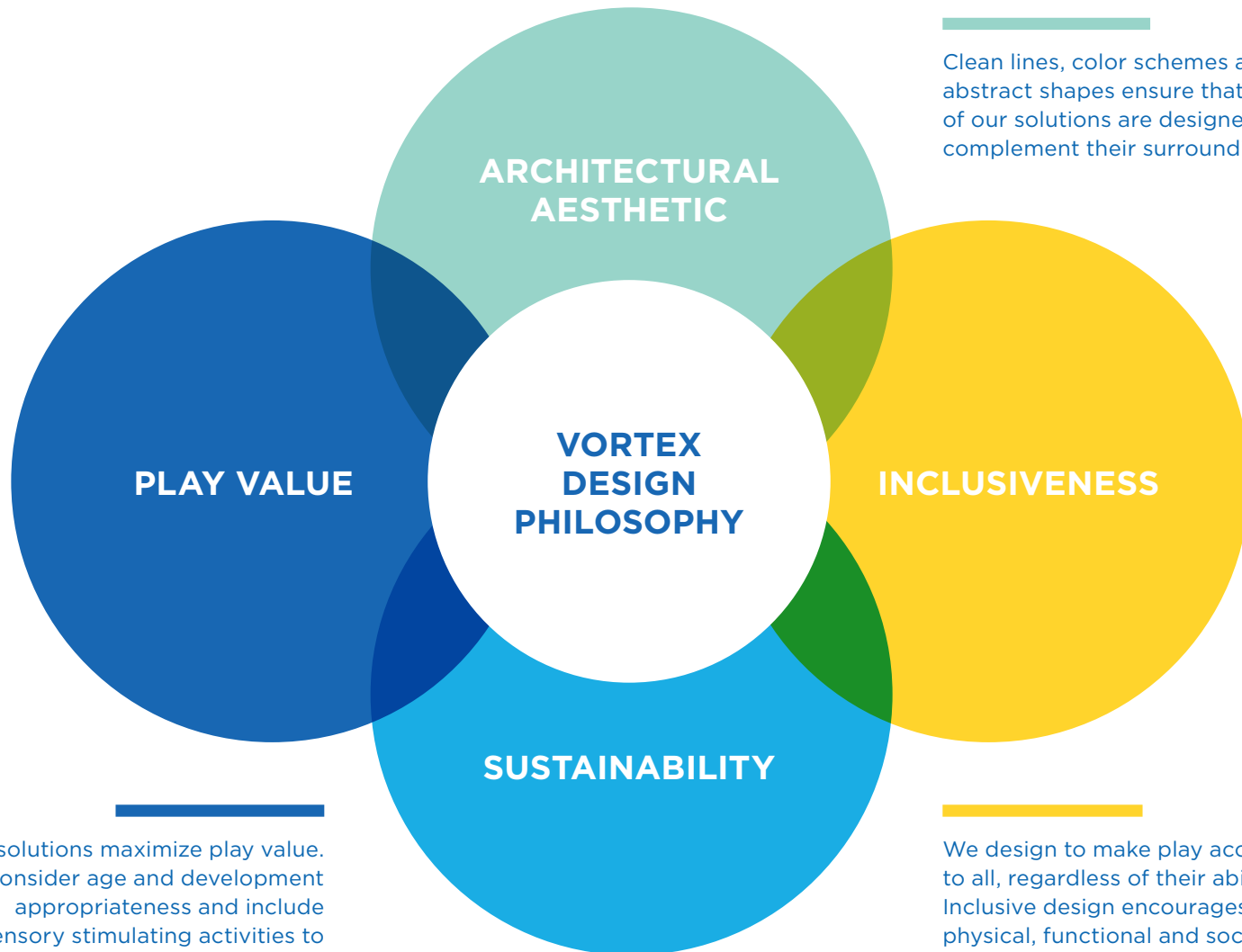

Clean lines, color schemes and abstract shapes ensure that all of our solutions are designed to complement their surroundings.

Our solutions maximize play value. We consider age and development appropriateness and include sensory stimulating activities to keep interest level high.

We design to make play accessible to all, regardless of their abilities. Inclusive design encourages the physical, functional and social development of children.

Advanced water management systems have been developed to help reduce water and energy consumption, while all of our solutions are built with durable, long-lasting materials.





**WE
INNOVATE
RELENTLESSLY
SO YOU
CAN HAVE
ALL THE
FUN**

VORTEX AQUATIC STRUCTURES INTERNATIONAL INC. IS THE WORLD LEADER IN AQUATIC PLAY LANDSCAPES AND ENTERTAINMENT. WITH INSTALLATIONS AT MORE THAN 6,000 LOCATIONS AROUND THE WORLD IN PUBLIC, COMMERCIAL AND ENTERTAINMENT SETTINGS, VORTEX INTERNATIONAL PROVIDES IMAGINATIVE, DURABLE AQUATIC PLAY AND WATER FEATURE SOLUTIONS THAT CREATE EVERLASTING MEMORIES. OUR ONGOING MISSION IS TO DEVELOP FUN, SAFE AND RELIABLE PRODUCTS FOR FAMILIES AND CHILDREN OF ALL AGES AND ABILITIES.



FISH N°1



Gentle
water effect



Rotates for added
play value



Seeflow™ tail makes
it easy to turn



VORTEX EXCLUSIVE TECHNOLOGIES

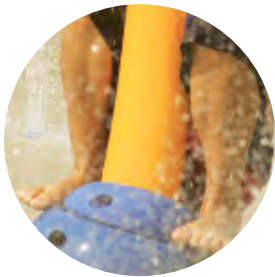

TOEGUARD™

- Soft-touch elastomer
 - Protects children's toes from anchoring hardware
 - Durable, vandal resistant, resistant to chemicals
 - Infused with a UV resistant bright color
 - Available in one or two pieces ensuring tight fit to post
-



SEEFLOW™

- Impact-resistant polymer
 - Resistant to UV rays and chemicals
 - Colorful reflections are created with the combination of bright colors, water, and sunlight
 - Manufactured with up to 40% pre-consumer recycled materials
 - Reusable at the end of life
-

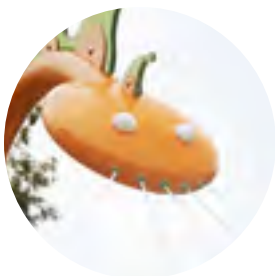

TRIFLOW™ NOZZLE

- One nozzle, three different water effect options
 - Stainless steel
 - Adjustable 360° cone spray
 - Internal diffuser for soft safe spray effect
 - Sleeved for easy maintenance
 - Tapered edges so it won't catch on anything
-





PODSPRAY™ (ON PRODUCT)

- Press to send water to another nozzle on the same feature
- Combine multiple pods and features to create team play
- Lead-free brass for maximum durability



PODSPRAY™ (GROUND)

- Step on or press to send water to another feature
- Increase flow to attached features to increase play value—connected features spin faster, spray farther, dance higher
- Combine multiple pods and features to create team play
- Lead-free brass for maximum durability



FUNFLOW ACTUATOR™

- Interactive cause & effect
- Encourages collaborative play
- Step on the cap to divert and multiply the water to another feature
- Low flow when not pressed to help save water
- No electrical required—simple installation



TURNTEC™

- Easy turning for kids of all ages and abilities
- Lead-free brass for maximum durability - heat resistant
- 360° rotation—no mechanical stops to break
- Adjustable spray zone—control the area where water begins and stops
- Corrosion and chemical resistant



SPINTEC™

- Kids can stand or sit on the platform while pushing off the ground to make the platform spin
 - Creates spiraling water effect
 - Manufactured with damper speed system that controls spinning speed
-



TWIRLTEC™

- Spin the round handle to create a spiraling water effect overhead
- Soft-touch elastomer
- Interactive cause and effect
- Friction-free, triple bearing system



LINEFLOW™ NOZZLE

- Precisely orient the stream of water with the internal brass marble
- Compact design provides better product integration
- Easy to adjust for the most efficient use of water based on your installation
- Made of lead-free brass for maximum durability



SAFESWAP™ ANCHORING SYSTEM

- Attractive ground caps are substituted for future play products
- Easily add future play elements with no change to infrastructure
- Easily move products from one location to another at no additional cost
- Provides flexibility to spread investment over time as capital becomes available
- Structural stainless steel base for maximum strength
- Optional interim spray cap



PRESS & PLAY ACTIVATOR

- On-demand activation saves water
- Constructed of durable stainless steel—vandal resistant
- No moving parts
- Low voltage—safe fun
- 2 wire connection for easy installation
- Easy operation for kids of all ages & abilities



TWIRLFLOW™

- Two linear jets create one twirling water effect from the water pressure
- 360° water jet creating a fragmented water splash, promoting dynamic play
- Visually captivating circular water movement
- Made of UHMW for superior durability

EXPERIENCE:

**Cory Anderson/GM Owner:
Over 250 designed Splashpads & 150 Turn-Key Installations**

**Installation Crew:
Over 30 years Experience in plumbing, electrical and concrete
Technicians for over 450 projects in Midwest**



**Local Office Support:
Located in Williamston, MI
We house spare parts for same day turn around on common parts**

AWARDS:

**Best Splashpad Design of the Year & Decade
by Aquatics International
KLR Splashpad
Oxford, Michigan**



**2013 NACPRO Award
Blue Heron Bay
Independence Lake, Michigan
National Park and Recreation Award for best design, planning and
construction to benefit a community. This pad is the largest Vortex
Splashpad every built.**

Blue Heron Bay at Independence Lake County Park in Michigan Wins Prestigious NACPRO Award Using the Largest Vortex Splashpad® Ever Built

Vortex Aquatic Structures International extends a well-deserved congratulations to Washtenaw County Parks & Recreation Commission for winning the award for the Blue Heron Bay Splashpad® they opened Memorial Day Weekend (May) 2013.

Montreal, Quebec ([PRWEB](#)) October 03, 2013 -- Vortex Aquatic Structures International is overjoyed by the recognition Washtenaw County Parks and Recreation Commission will receive for the extraordinary spray park they built and that [Vortex Midwest](#) could be part of the project. The NACPRO awards is an annual recognition given to individuals, programs and innovative installations that contribute to the American park system. The category for which Blue Heron Bay at Independence Lake County Park won – the Park and Recreation Award (Class I) - was to honor and focus national attention on their spray park installation as the best in design, planning, construction and benefit to the community.

The Blue Heron Bay is the largest [Splashpad®](#) complex in North America with over 20,000 square feet, and with the greatest number of water features. It took two years and cost \$4 million dollars to complete. It replaced a former splash park that had operated for about 12 summers and was mechanically failing. The new project involved building the spray park in a more centrally located area in the 414 acre park, significantly improving access to the amenity. Using a Vortex Splashpad®, the spray park implemented some of the most advanced technology in sustainable water usage, including: water distribution system, nozzles, spray sequences, flow controllers and intervals of usage. It also benefits from having the largest Vortex Water Quality Management System (WQMS) ever built, manufactured for the highest efficiency in water recirculation, and includes a UV water treatment to kill over 99% of all harmful bacteria. The splash pad itself can accommodate about 420 people, and will operate from Memorial Day to Labor Day each year.

“Spray parks are colorful and exciting. They offer greater value than a traditional pool and have a much higher fun value,” said Jeff Dehring PLA, ASLA, Principal Park Planner for Washtenaw County. “We are delighted to have won this prestigious award from NACPRO and thank Vortex for being such incredible partners in turning our vision into reality.”

“Blue Heron Bay is truly something special not only for the community, but also the Midwest, it has all the amenities for the whole family, regardless of age or ability,” said Cory Anderson, Managing Partner Vortex Midwest. “We are honored to have been chosen as part of the design team for this project and congratulate Washtenaw County on the win.”

The Splashpad® is divided into three areas: a toddler zone features free standing bubbling fountains, plus a turtle and frog who spit large mouthfuls of water on younger children; a sizable family zone, whose main focal feature is the Elevation™ structure highlighted by the Superwave: a tall spinning wheel that slowly fills with water before dumping it on the excited children below. The third “interactive” zone is located at the opposite end of the park from the toddler’s section and features a 15’ large spider that sprays webs of water in response to activating its Funflow Actuator™. The splash park also has a two-story water slide with two flumes: one that’s enclosed and one that’s open. This is attached to a 24’ tower and uses a run out, rather than a pool, to allow shorter riders & non-swimmers to enjoy the slides.

Vortex will participate in the upcoming NRPA Congress and Exhibition from October 8-10th in Houston,

Award Winning Splashpads



KLR Splashpad Oxford, MI

Ron Davis
248-628-1720
rdavis@oxparkrec.org



Blue Heron Bay Splashpad

Jeff Dehring
734-971-6337
dehringj@ewashtenaw.org

Accessibility :

**Cory Anderson
GM/Owner
Project Coordination
1-877-586-7839 Ext. 362
517-488-9469 Cell
cory@vortex-midwest.com
Williamston, MI**

**Angie Monroe
Office Manager
1-877-586-7839 Ext. 361
517-375-2316 Cell
angie@vortex-midwest.com
Williamston, MI**



**Jeff Myszak
Installation Specialist
517-202-4157 cell
jeff@vortex-midwest.com
Williamston, MI**

**Darrell Klein
Installation Specialist
989-277-5908 cell
darrell@vortex-midwest.com
Williamston, MI**

Design Highlights
Materials:

Stainless Steel

Brass

Seeflow Polymer

Soft touch elastomer Toe Guards

Superior Powder Coating with Additional UV treatment



Flush Nozzles

No Trip hazards

Fail Safe Activator

No finger/toe entrapments

REFERENCES:



**Thorn Park Splashpad
Brownstown, MI**

**Vern Gustafsson
734-675-5913
vgustafsson@brownstown-mi.org**



**Blue Heron Bay
Washtenaw County, MI**

**Jeff Dehring
734-971-6337
dehringj@ewashtenaw.org**



**The Centre Splashpad
Adrian, MI**

**Ryan Johnson
517-438-8837
rjohnson@lenawee.org**



**Splash Playground
Canton, MI**

**Brad Sharp
734-394-5363
brad.sharp@canton-mi.org**

Ypsilanti Splashpad by Vortex

**\$845,000.00
Turnkey**



It's always easy and a pleasure to refer the Vortex product line simply because of its quality. The Vortex equipment and customer service speaks for itself.

RON DAVIS

DIRECTOR OF PARKS & RECREATION | OXFORD TOWNSHIP, MICHIGAN, USA



Ypsilanti Splashpad®, MI - Option 01
Rev 00 - 23972

View 1



Ypsilanti Splashpad®, MI - Option 01
Rev 00 - 23972

View 2



Ypsilanti Splashpad®, MI - Option 01
Rev 00 - 23972

View 3



Ypsilanti Splashpad®, MI - Option 01
Rev 00 - 23972

View 4





Ypsilanti Splashpad®, MI - Option 01
Rev 00 - 23972

View 5

ELEVATIONS™ COMPONENTS



#	ITEM	QTY	GPM	LPM
INTERACTIVE WATER PLAY FEATURES				
1	Aquadome	1	20	76
2	Deck Geysers	2	20	76
3	Spray Cannons	2	40	152
4	Orb Spray No2	2	40	152
5	Spray Bar	5	100	380
6	Plux Perispray	1	20	76
WATER PLAY FEATURES				
7	Dumping Bucket	2	40	152
8	Dumping Bucket Panel	1	20	76
9	Pipe fall	1	60	227
10	Seven falls	2	80	302
11	Spinner	1	40	151
12	Superwave	1	38	144
13	Water Dome	1	40	151
14	Water wall/sheet	1	60	227
15	Custom Front Boat	1	40	151
16	Fiberglass water slide	1	40	151
17	Fiberglass water close tube	1	200	757
PLAY FEATURES				
TOTAL WATER FLOW		26	898GPM	3401LPM

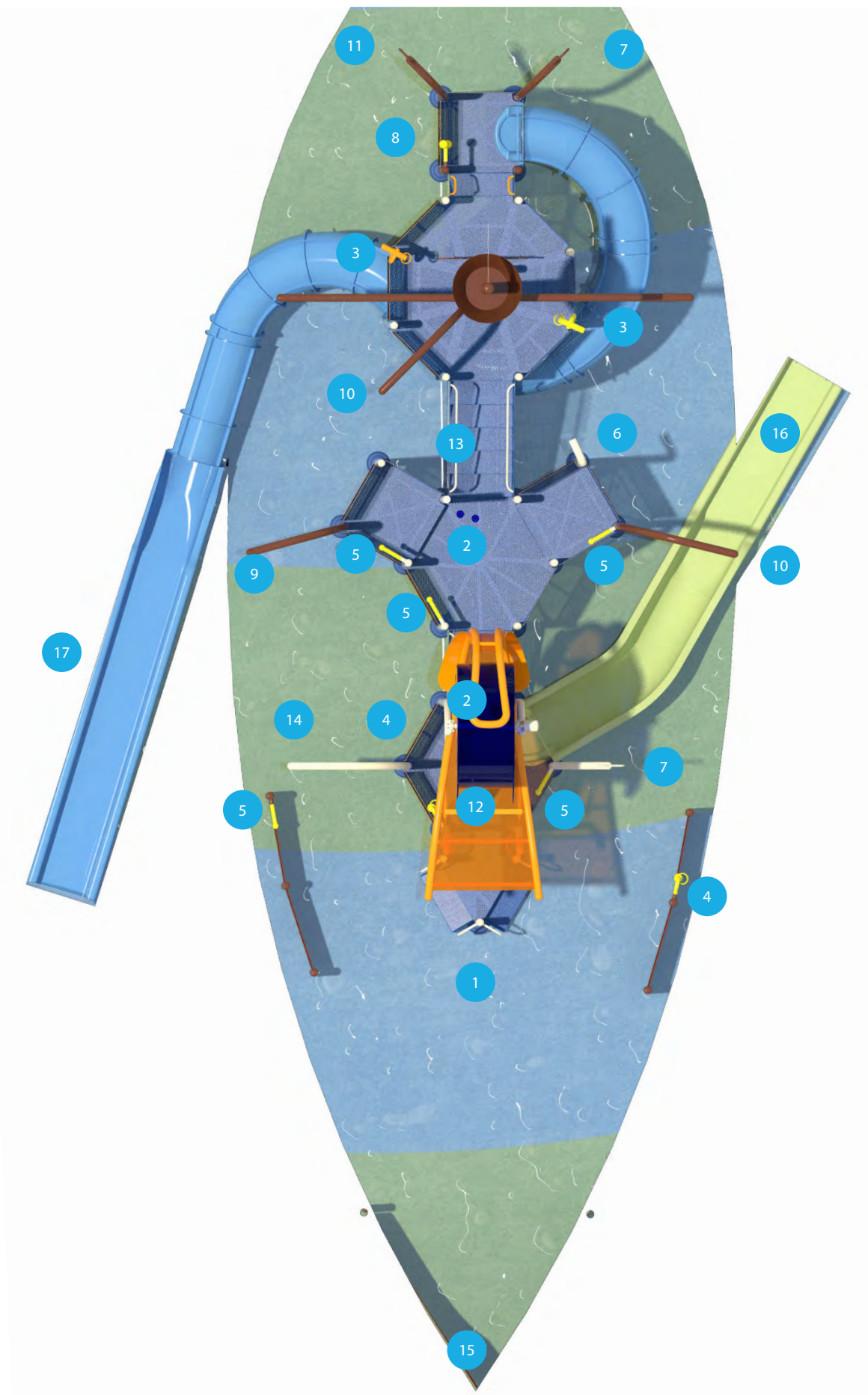

VORTEX AQUATIC STRUCTURES INTERNATIONAL INC. VORTEX-INTL.COM | 877.586.7839 ©2012 VORTEX INTERNATIONAL, ALL RIGHTS RESERVED

ELEVATIONS™ COMPONENTS



#	ITEM	QTY	GPM	LPM
TOTAL WATER FLOW		26	898GPM	3401LPM
STRUCTURES COMPONENTS		QTY	GPM	LPM
A	Entry 32"	1	n/a	n/a
B	Hex 32" (+Manifold)	1	228	864
C	3 Steps	1	n/a	n/a
D	Hex 64" (+Manifold)	1	230	871
E	Square 72"	2	n/a	n/a
F	5 Steps	1	n/a	n/a
G	Octa 112"	1	80	303
H	Square 96"	1	280	1060
Main Posts				
Barrier Graphics		SPLASHIE / OCEAN / JUNGLE A / B / A&B		

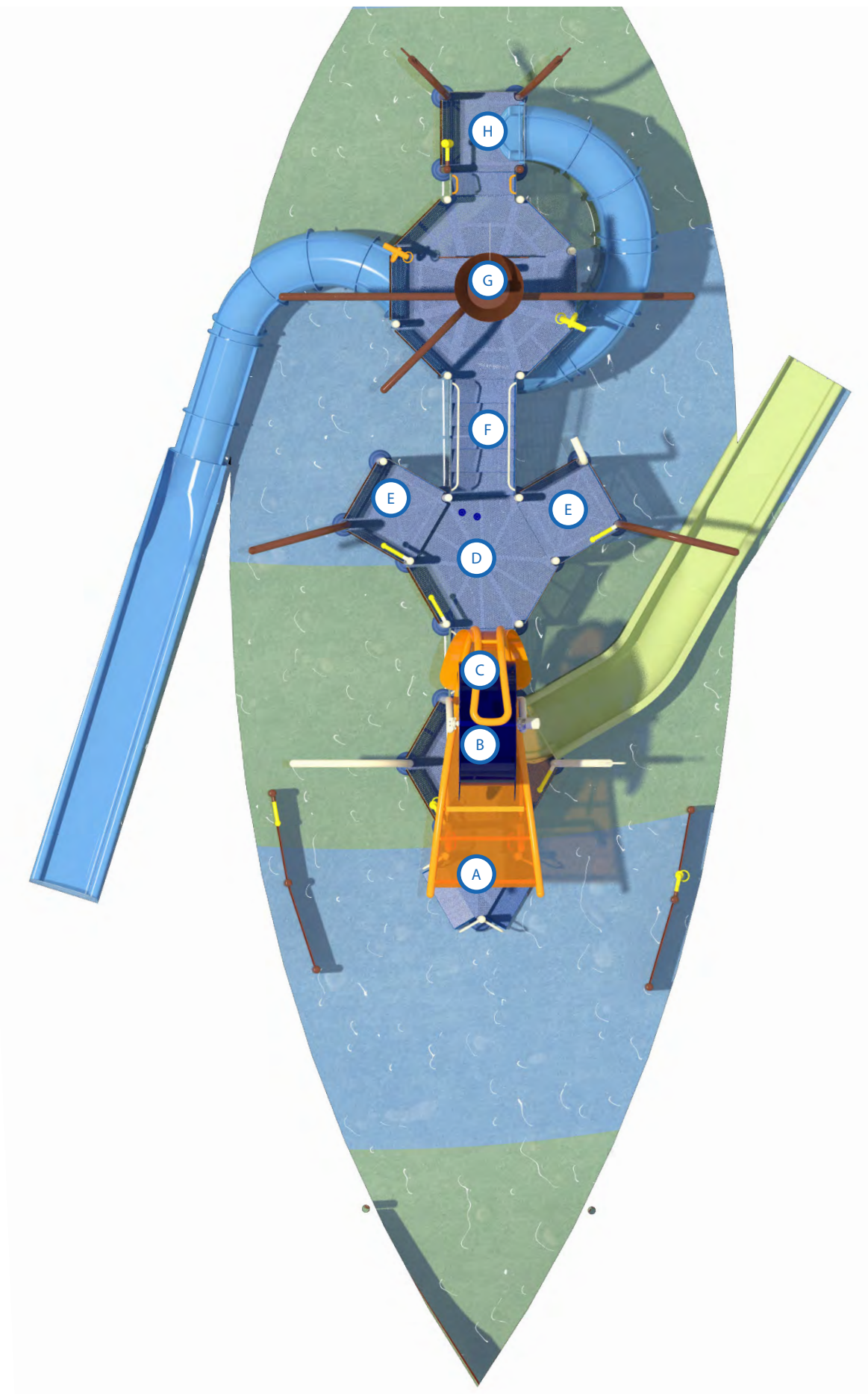

Top View Elevations™



SPLASHPAD® COMPONENTS



TOTAL AREA: 6200 ft²(546 m²)
 SPRAY AREA: 4825 ft²(448 m²)

#	ITEM	QTY	GPM	LPM
1	custom evation VOR 8537.0000	1	898	3401
2	directional water jet VOR 305	4	16	60.4
3	ground geyser VOR 301	2	15	56.8
4	jet stream VOR 7512	4	10	38
5	team spray No1 VOR 7640	1	17.5	66.3
6	team spray No2 VOR 8061	1	34	128.7
7	tube No1 VOR 220	3	22.5	85.2
8	water jelly No5 VOR 7033	1	32.5	123
9	watergarden fish No1 VOR 7218	1	4	15
10	Sea Silhouette Lanternfish VOR 7682	1	8	30.3
11	Sea Silhouette Seahorse VOR 7684	1	5.5	20.8
12	Sea Silhouette Crab Claw VOR 7686	1	10	38
13	Sea Silhouette Octopus VOR 7691	1	26	98.4
14	Seaweed No1 VOR 7779	1	3	11.3
15	Seaweed No2 VOR 7780	2	9	34
16	playsafe drain No1 VOR 1001.4000	3	n/a	n/a
17	watergarden activator no2 VOR 612	1	n/a	n/a
		QTY	GPM	LPM
TOTAL WATER FLOW		30	1111	4207.2

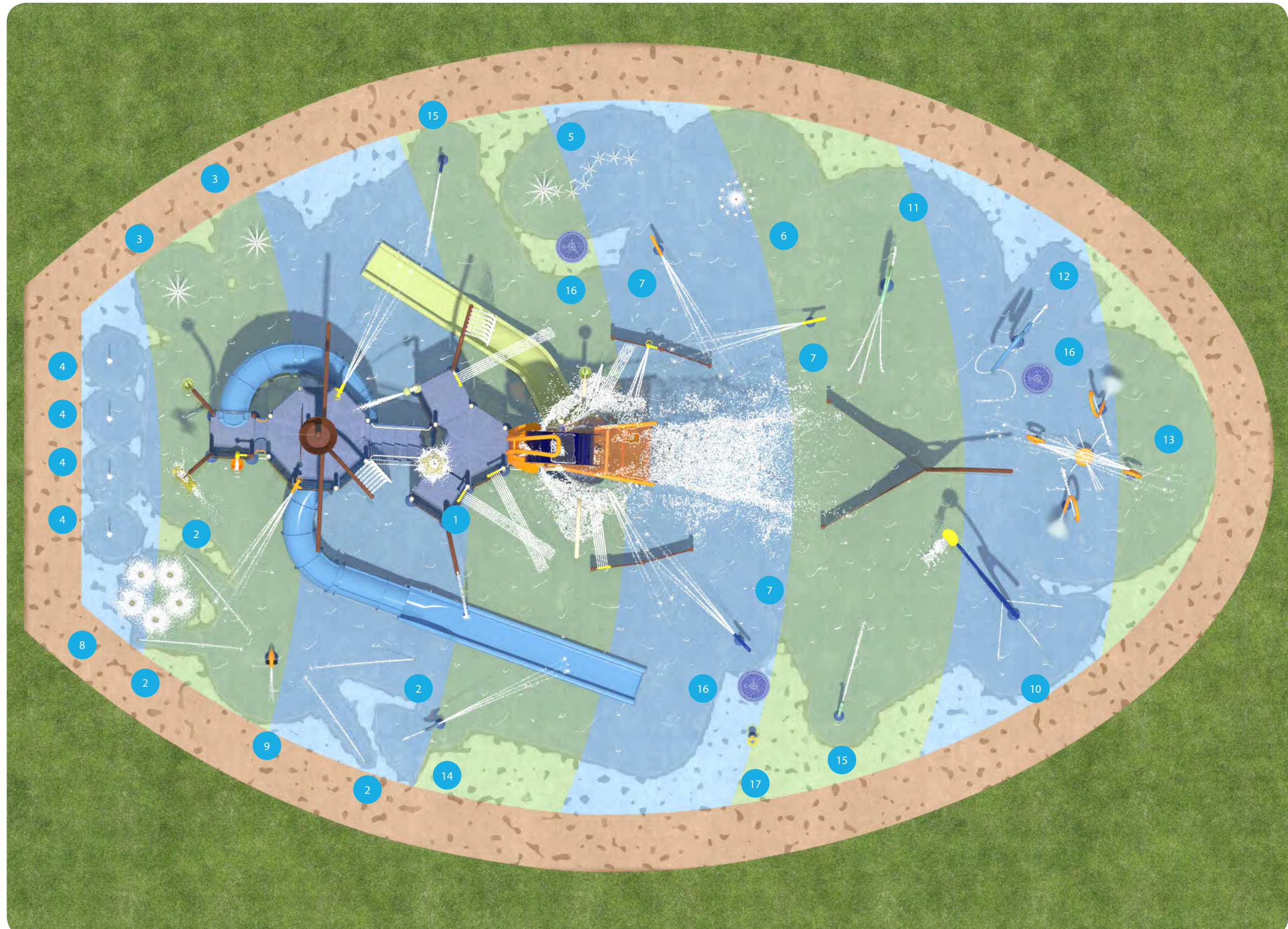

VORTEX AQUATIC STRUCTURES INTERNATIONAL INC. VORTEX-INTL.COM | 877.586.7839 ©2012 VORTEX INTERNATIONAL, ALL RIGHTS RESERVED

ELEVATIONS™ COLOR CHOICES

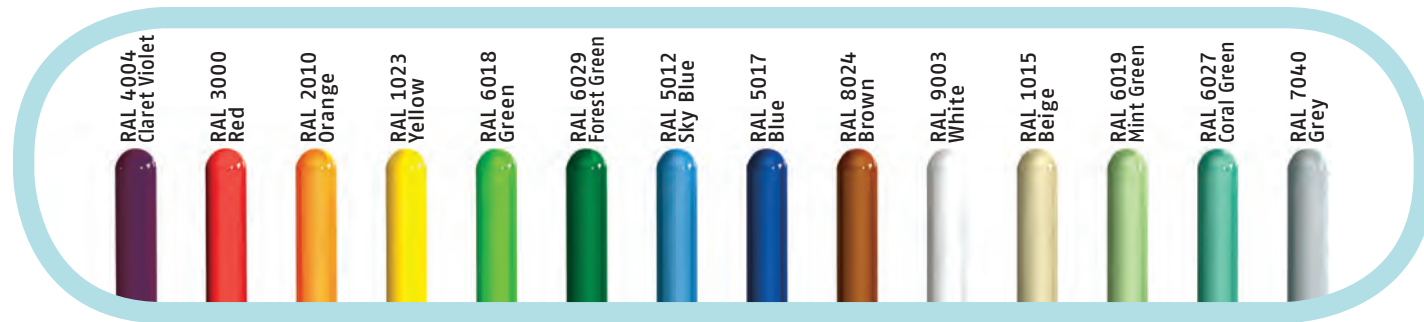

Posts



Seeflow™ Colors



Seeflow™ Dumping Bells & Flower



Toeguard™

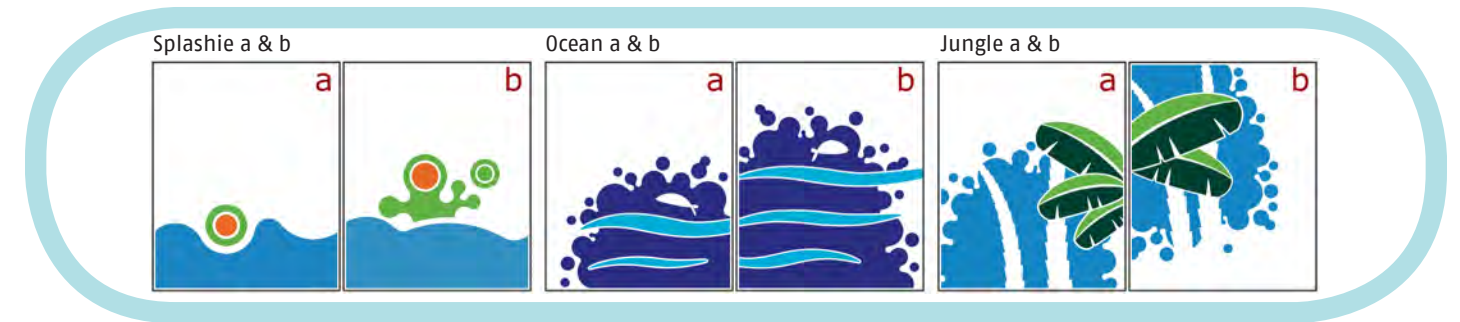

Seeflow™ Barrier Graphics



Fiberglass Water Slides & Supersplash Buckets

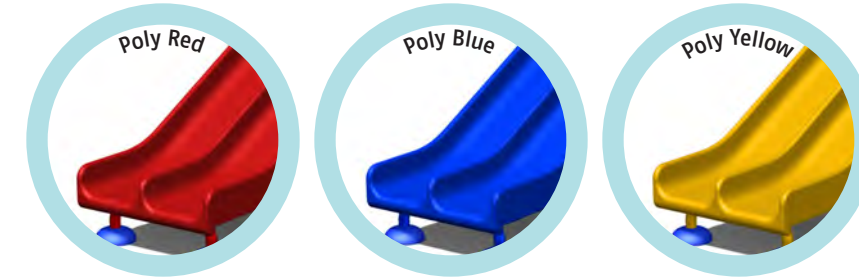

Poly Slides



Handle Sphere

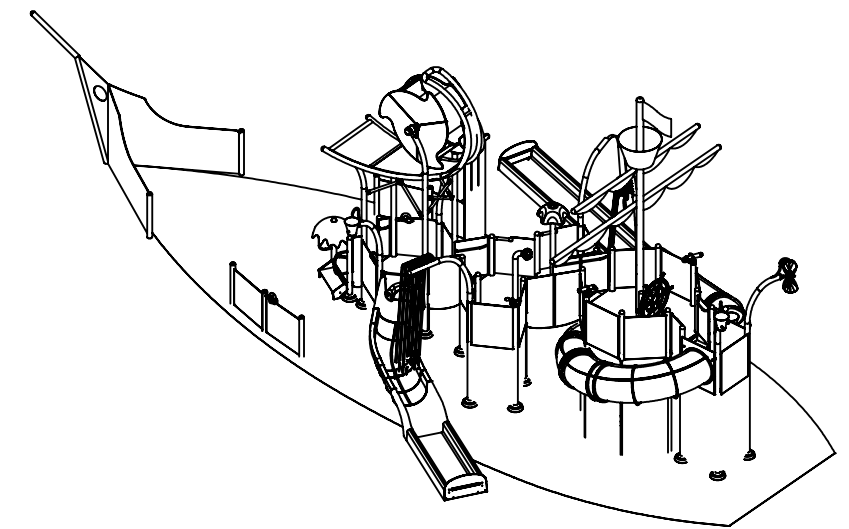
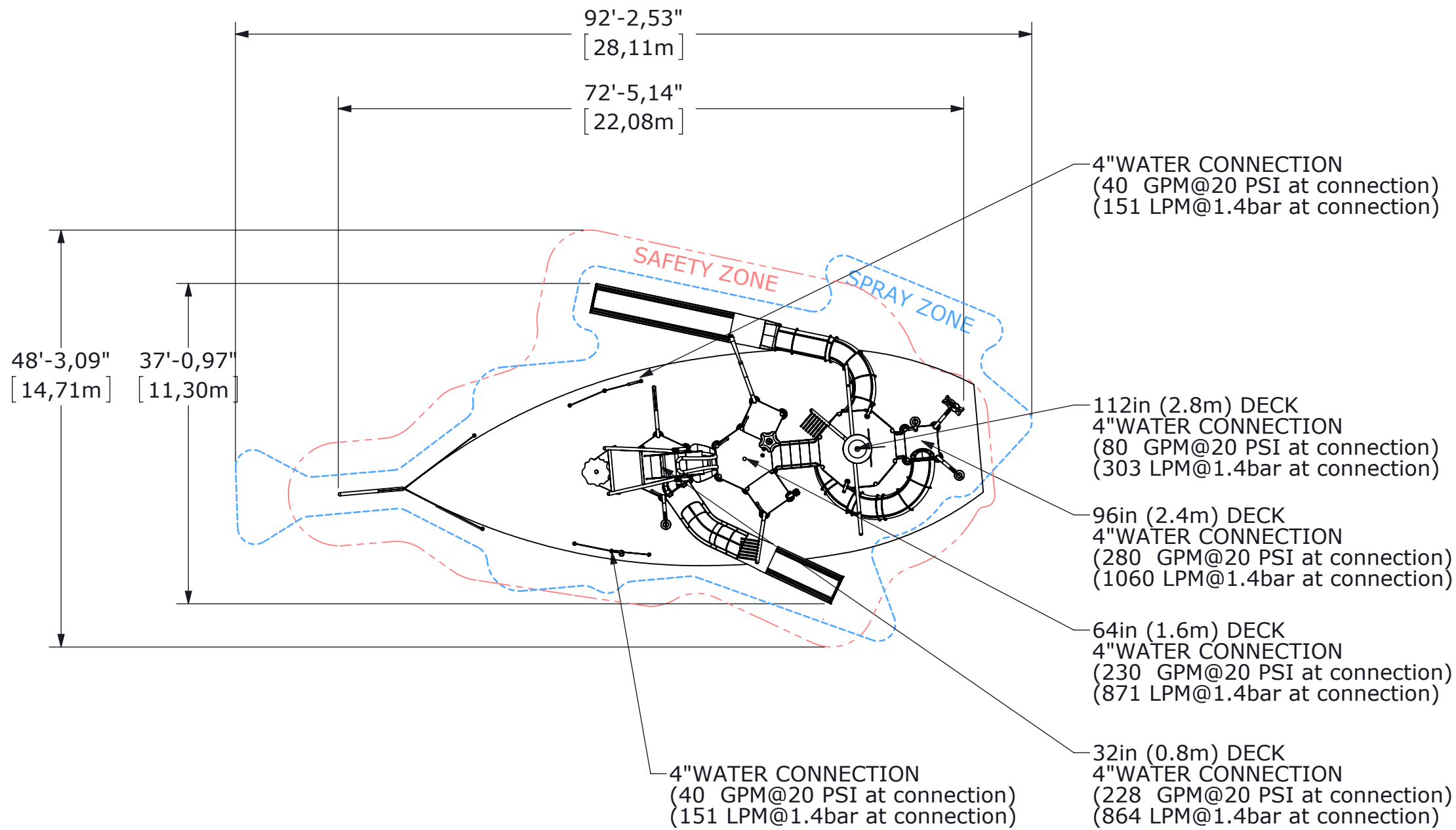

ELEVATIONS LEGEND
 Nb. of water anchors=4
 Nb. deck=4
 Nb. interactive features=13
 Nb. overhead features=11
 Nb. water slides=2

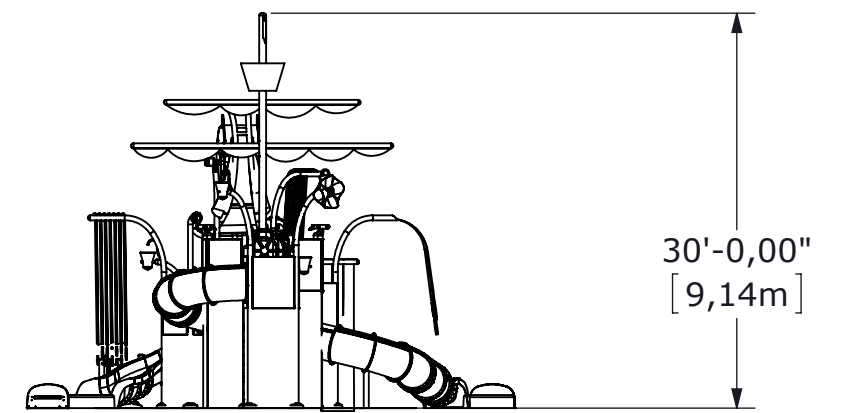
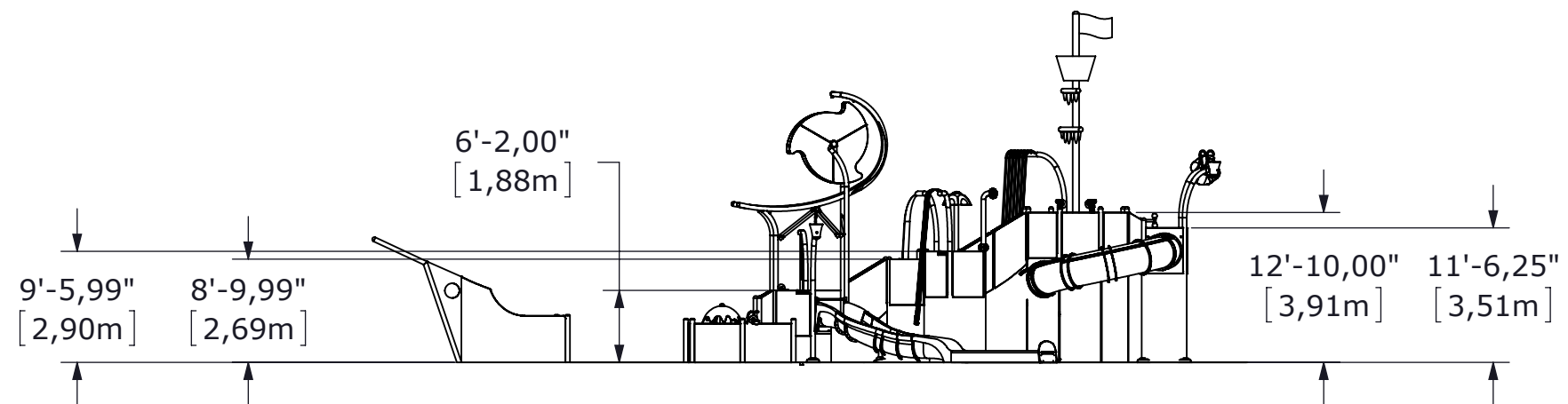

PROJECT NAME: PALOS DE LA FRONTERA, ES	ELEVATIONS MODEL: L4	PROPOSAL REVISION: REV-00	
DRAWING TITLE: GENERAL VIEWS	DATE: JANUARY/05/2014	DESIGNER: D SCHERTENLEIB	

Splashpad[®]

SPECTACULAR FUN

A Splashpad[®] is a dynamic, zero-depth aquatic play area that provides endless hours of fun for the entire family. Splashpad[®] combines the sensations of different water movements—flowing, misting, and jetting—with over 250 diverse features for an unequalled aquatic play adventure.



VORTEX

A CLEAR
SOURCE
OF
FUN

VOR 7691 SEA SILHOUETTE OCTOPUS

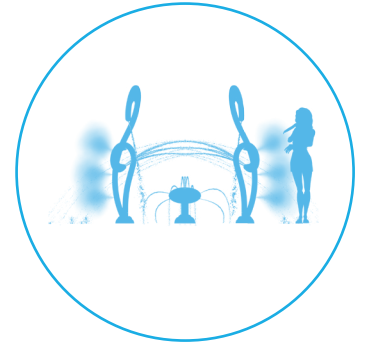
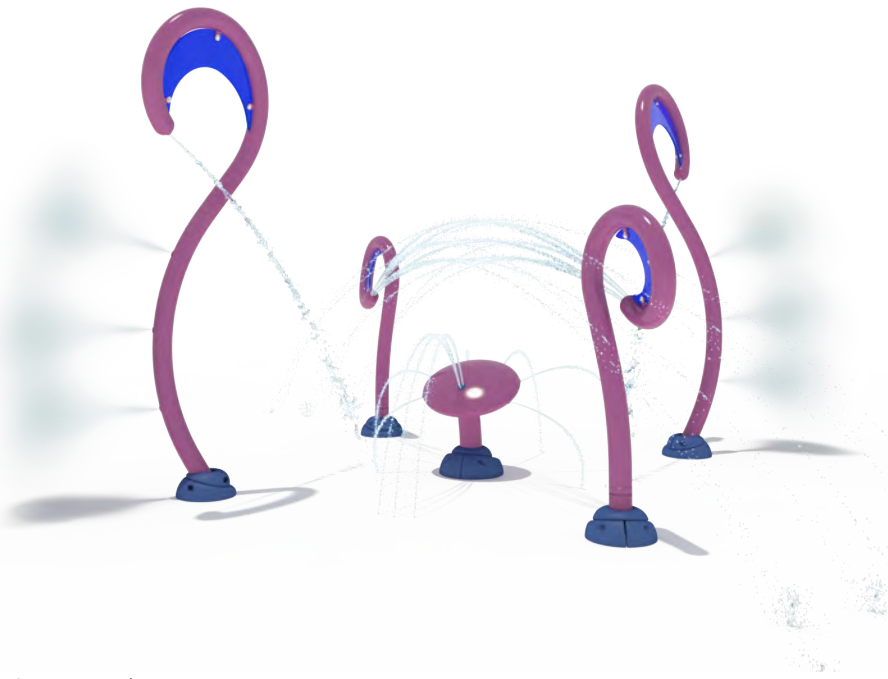

Ideal age group: 6 years and up

PRODUCT HIGHLIGHTS

- Press on the Podspray™ from the feature to amplify the water effect
- Intuitive 360° rotation with no pinch point on the tentacles for more play value
- Encourages immersive play with different water effects
- Projects colorful shadows with the Seeflow™ for visual experience



*This Octopus wants
to play with you!*

You may also like



• Sea Silhouette Pelican
(VOR 7688)

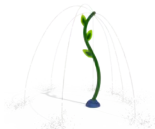

• Seaweed N°3
(VOR 7781)



• Seaweed N°2
(VOR 7780)



• Crab N°1
(VOR 7208)



World leader in aquatic play solutions with over
6,000 installations worldwide
vortex-intl.com • info@vortex-intl.com
1.877.586.7839 (free USA/CND) • +1.514.694.3868 (Intl.)

Spray Zone

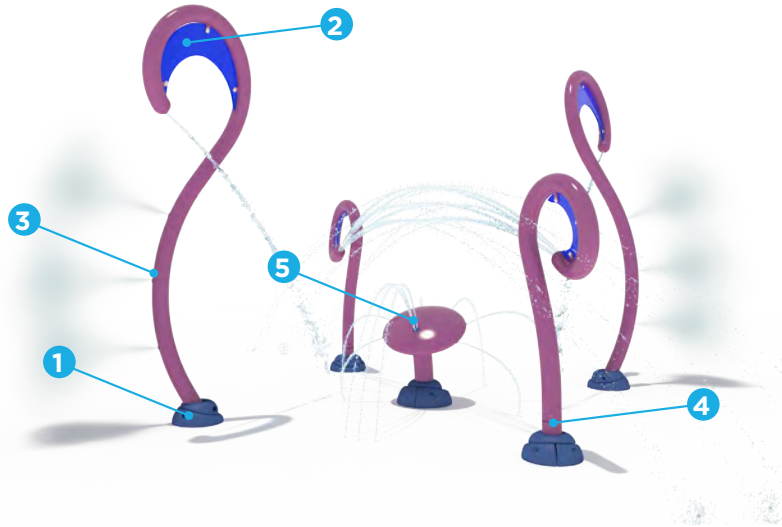

Ø 270" (Ø 686 cm)

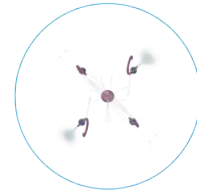

H/W/L	Pressure
85/134/129 in	10-25 PSI
216/340/327 cm	0.68-0.70 BAR

Flow	Smartflow
20-32 GPM	-
75.71-121.13 LPM	-

Color Choices: Vortex colors

VORTEX EXCLUSIVE TECHNOLOGIES

This product features the following technologies that are unique to Vortex.



TOEGUARD™

- Soft-touch Elastomer
- Protects children's toes from anchoring hardware
- Durable, vandal resistant, resistant to chemicals
- Infused with a UV resistant bright color
- Available in one or two pieces ensuring tight fit to post



SEEFLOW™

- Impact-resistant polymer
- Resistant to UV rays and chemicals
- Colorful reflections are created with the combination of bright colors, water, and sunlight
- Manufactured with up to 40% pre-consumer recycled materials
- Reusable at the end of life



TRIFLOW™ NOZZLE

- One nozzle, three different water effect options
- Stainless Steel
- Adjustable 360° cone spray
- Internal diffuser for soft safe spray effect
- Sleeved for easy removal and replacement
- Tapered edges so it won't catch on anything



TURNTEC™

- Easy turning for kids of all ages and abilities
- Lead-free brass for maximum durability - heat resistant
- 360° rotation - no mechanical stops to break
- Adjustable spray zone - control the area where water begins and stops
- Corrosion and chemical resistant



PODSPRAY™ (ON PRODUCT)

- Simply press to send water to another nozzle on the same feature
- Combine multiple pods and features to create team play
- Lead-free brass for maximum durability

WATER EFFECTS

- Misty jet (6)
- Jet stream (5)
- Cannon jet (2)
- Interactive Podspray™ (1)



World leader in aquatic play solutions with over 6,000 installations worldwide
 vortex-intl.com • info@vortex-intl.com
 1.877.586.7839 (free USA/CND) • +1.514.694.3868 (Intl.)



VOR 7682 SEA SILHOUETTE LANTERNFISH

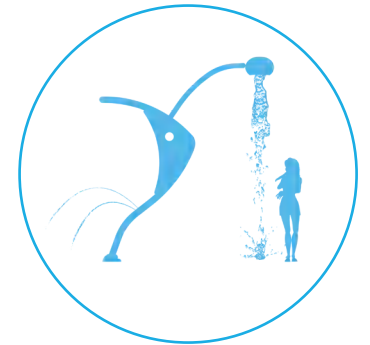

Ideal age group: 4 years and up

PRODUCT HIGHLIGHTS

- Predict and anticipate when its bucket will spill over
- Encourages the imagination and creative play
- Projects colorful shadows with the Seeflow™ for visual experience



*This Lanternfish
wants to play!*

You may also like



• Sea Silhouette Angelfish
(VOR 7685)



• Sea Silhouette Fish
(VOR 7687)



• Seaweed N°1
(VOR 7779)



World leader in aquatic play solutions with over
6,000 installations worldwide
vortex-intl.com • info@vortex-intl.com
1.877.586.7839 (free USA/CND) • +1.514.694.3868 (Intl.)

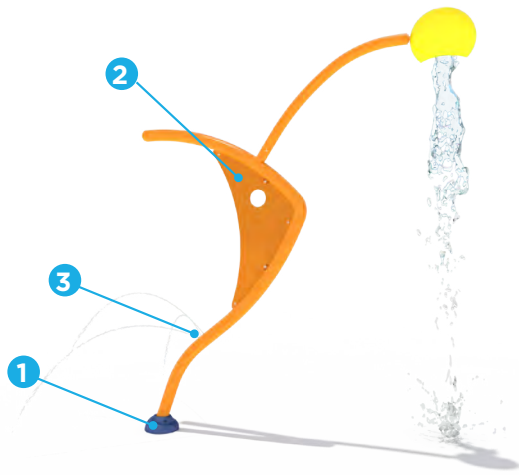

Spray Zone

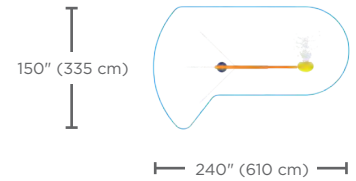

H/W/L	Pressure
142/120/13 in	6-10 PSI
361/305/33 cm	0.40-0.70 BAR

Flow	Smartflow
6-10 GPM	-
22.71-37.85 LPM	-
Color Choices: Vortex colors	

VORTEX EXCLUSIVE TECHNOLOGIES

This product features the following technologies that are unique to Vortex.



TOEGUARD™

- Soft-touch Elastomer
- Protects children's toes from anchoring hardware
- Durable, vandal resistant, resistant to chemicals
- Infused with a UV resistant bright color
- Available in one or two pieces ensuring tight fit to post



SEEFLOW™

- Impact-resistant polymer
- Resistant to UV rays and chemicals
- Colorful reflections are created with the combination of bright colors, water, and sunlight
- Manufactured with up to 40% pre-consumer recycled materials
- Reusable at the end of life



TRIFLOW™ NOZZLE

- One nozzle, three different water effect options
- Stainless Steel
- Adjustable 360° cone spray
- Internal diffuser for soft safe spray effect
- Sleeved for easy removal and replacement
- Tapered edges so it won't catch on anything

WATER EFFECTS

- Dumping water bucket (1)
- Jet stream (3)



World leader in aquatic play solutions with over 6,000 installations worldwide
 vortex-intl.com • info@vortex-intl.com
 1.877.586.7839 (free USA/CND) • +1.514.694.3868 (Intl.)



VOR 7684 SEA SILHOUETTE SEAHORSE

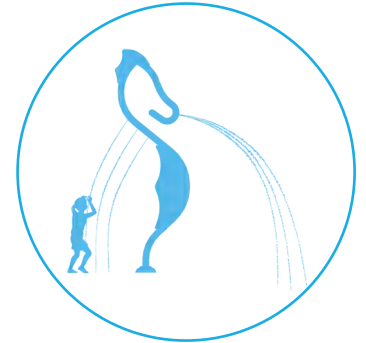
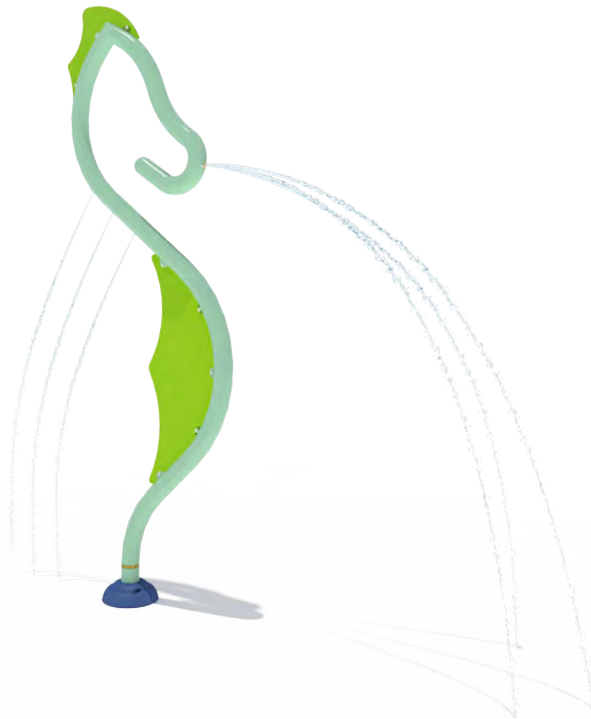

Ideal age group: 6 years and up

PRODUCT HIGHLIGHTS

- Intuitive 360° rotation with no pinch point
- Encourages the imagination and creative play
- Projects colorful shadows with the Seeflow™ for visual experience



This Seahorse is friendly!

You may also like



• Sea Silhouette Angelfish (VOR 7685)



• Sea Silhouette Lanternfish (VOR 7682)



• Seaweed N°2 (VOR 7780)



World leader in aquatic play solutions with over 6,000 installations worldwide
 vortex-intl.com • info@vortex-intl.com
 1.877.586.7839 (free USA/CND) • +1.514.694.3868 (Intl.)

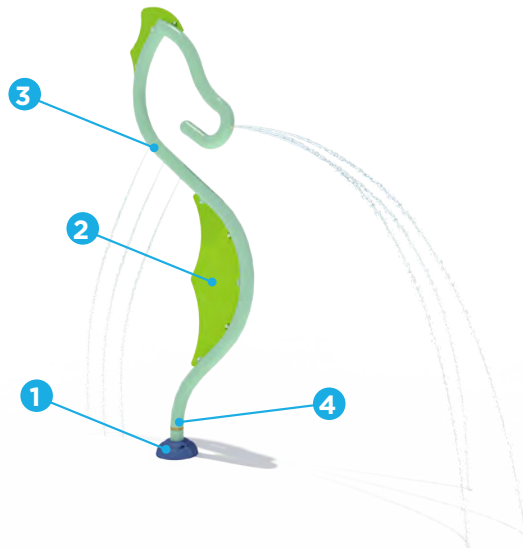

Spray Zone

Ø 240" (Ø 610 cm)

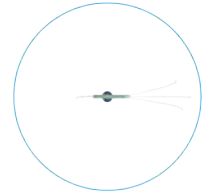

H/W/L	Pressure
150/50/13 in	6-8 PSI
381/127/33 cm	0.40-0.60 BAR

Flow	Smartflow
4-7 GPM	-
15.14-26.50 LPM	-
Color Choices: Vortex colors	

VORTEX EXCLUSIVE TECHNOLOGIES

This product features the following technologies that are unique to Vortex.



TOEGUARD™

- Soft-touch Elastomer
- Protects children's toes from anchoring hardware
- Durable, vandal resistant, resistant to chemicals
- Infused with a UV resistant bright color
- Available in one or two pieces ensuring tight fit to post



SEEFLOW™

- Impact-resistant polymer
- Resistant to UV rays and chemicals
- Colorful reflections are created with the combination of bright colors, water, and sunlight
- Manufactured with up to 40% pre-consumer recycled materials
- Reusable at the end of life



TRIFLOW™ NOZZLE

- One nozzle, three different water effect options
- Stainless Steel
- Adjustable 360° cone spray
- Internal diffuser for soft safe spray effect
- Sleeved for easy removal and replacement
- Tapered edges so it won't catch on anything



TURNTEC™

- Easy turning for kids of all ages and abilities
- Lead-free brass for maximum durability - heat resistant
- 360° rotation - no mechanical stops to break
- Adjustable spray zone - control the area where water begins and stops
- Corrosion and chemical resistant

WATER EFFECTS

- Interactive jet stream (4)



World leader in aquatic play solutions with over 6,000 installations worldwide
 vortex-intl.com • info@vortex-intl.com
 1.877.586.7839 (free USA/CND) • +1.514.694.3868 (Intl.)



VOR 7686 SEA SILHOUETTE CRAB CLAW



Ideal age group: 6 years and up

PRODUCT HIGHLIGHTS

- Press on the Podspray™ from the feature to amplify the water effects
- Play by dodging the twirling water effect from the Twirlflow™
- Encourages the imagination and creative play
- Projects colorful shadows with the Seeflow™ for visual experience



This Crab Claw will catch you!

You may also like



• Sea Silhouette Crab (VOR 7690)



• Fish N°1 (VOR 7218)



• Turtle N°2 (VOR 7216)



• Sea Silhouette Lanternfish (VOR 7682)



World leader in aquatic play solutions with over 6,000 installations worldwide
 vortex-intl.com • info@vortex-intl.com
 1.877.586.7839 (free USA/CND) • +1.514.694.3868 (Intl.)

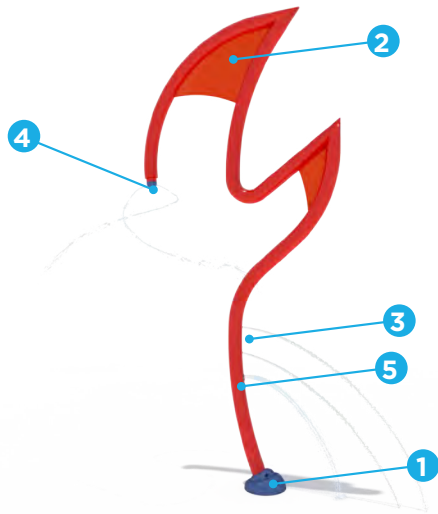

Spray Zone

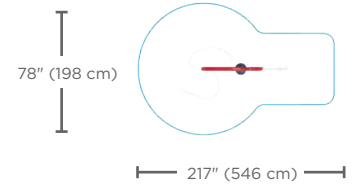

H/W/L	Pressure
148/67/13 in	6-10 PSI
376/170/33 cm	0.40-0.70 BAR

Flow	Smartflow
7-13 GPM	-
27-49 LPM	-

Color Choices: Vortex colors

VORTEX EXCLUSIVE TECHNOLOGIES

This product features the following technologies that are unique to Vortex.



TOEGUARD™

- Soft-touch Elastomer
- Protects children's toes from anchoring hardware
- Durable, vandal resistant, resistant to chemicals
- Infused with a UV resistant bright color
- Available in one or two pieces ensuring tight fit to post



SEEFLOW™

- Impact-resistant polymer
- Resistant to UV rays and chemicals
- Colorful reflections are created with the combination of bright colors, water, and sunlight
- Manufactured with up to 40% pre-consumer recycled materials
- Reusable at the end of life



TRIFLOW™ NOZZLE

- One nozzle, three different water effect options
- Stainless Steel
- Adjustable 360° cone spray
- Internal diffuser for soft safe spray effect
- Sleeved for easy removal and replacement
- Tapered edges so it won't catch on anything



TWIRLFLOW™

- Two linear jets that create one twirling water effect from the water pressure
- 360° water jet creating a fragmented water splash, promoting dynamic play
- Visually captivating circular water movement
- Made of UHMW for superior durability



PODSPRAY™ (ON PRODUCT)

- Simply press to send water to another nozzle on the same feature
- Combine multiple pods and features to create team play
- Lead-free brass for maximum durability

WATER EFFECTS

- Spiral water jet (2)
- Interactive Podspray™ (1)
- Jet stream (2)



World leader in aquatic play solutions with over 6,000 installations worldwide
 vortex-intl.com • info@vortex-intl.com
 1.877.586.7839 (free USA/CND) • +1.514.694.3868 (Intl.)



VORTEX
A CLEAR SOURCE OF FUN

Ideal age group: 0 - 6 years

VOR 7218 FISH N°1

PRODUCT HIGHLIGHTS

- Gentle water effect
- Rotates for added play value
- Seeflow™ tail makes it easy to turn



Hold on to the fish's tail as it takes you for a swim under the sea!

You may also like



• Snail N°4 (VOR 7217)



• ab N°1 (OR 7208)



• Frog N°4 (VOR 7203)



• Snake N°2 (VOR 7214)



World leader in aquatic play solutions with over 6,000 installations worldwide
 vortex-intl.com • info@vortex-intl.com
 1.877.586.7839 (free USA/CND) • +1.514.694.3868 (Intl.)

Spray Zone

ø 12"
(ø 307 cm)

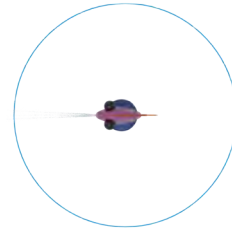

H/W/L	Pressure
33/27/14 in	10 - 15 PSI
83/69/36 cm	0.7 - 1 BAR

Flow	Smartflow
5-10 GPM	-
19-38 LPM	-

Color Choices: Vortex colors

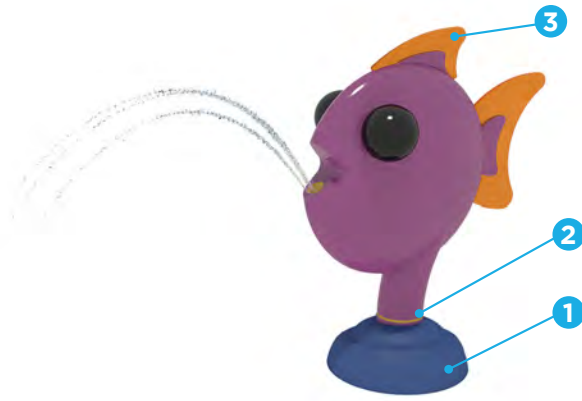

VORTEX EXCLUSIVE TECHNOLOGIES

This product features the following technologies that are unique to Vortex.



TOEGUARD™

- Soft-touch Elastomer
- Protects children's toes from anchoring hardware
- Durable, vandal resistant, resistant to chemicals
- Infused with a UV resistant bright color
- Available in one or two pieces ensuring tight fit to post



TURNTEC™

- Easy turning for kids of all ages and abilities
- Lead-free brass for maximum durability - heat resistant
- 360° rotation - no mechanical stops to break
- Adjustable spray zone - control the area where water begins and stops
- Corrosion and chemical resistant



SEEFLOW™

- Impact-resistant polymer
- Resistant to UV rays and chemicals
- Colorful reflections are created with the combination of bright colors, water, and sunlight
- Manufactured with up to 40% pre-consumer recycled materials
- Reusable at the end of life

WATER EFFECTS

- Gentle jet stream (6)

Features, anchoring systems and hardware are made of 100% recyclable stainless steel, including at least 25% post-consumer recycled content.



World leader in aquatic play solutions with over 6,000 installations worldwide
vortex-intl.com • info@vortex-intl.com
1.877.586.7839 (free USA/CND) • +1.514.694.3868 (Intl.)



VOR 7779 SEAWEED N°1

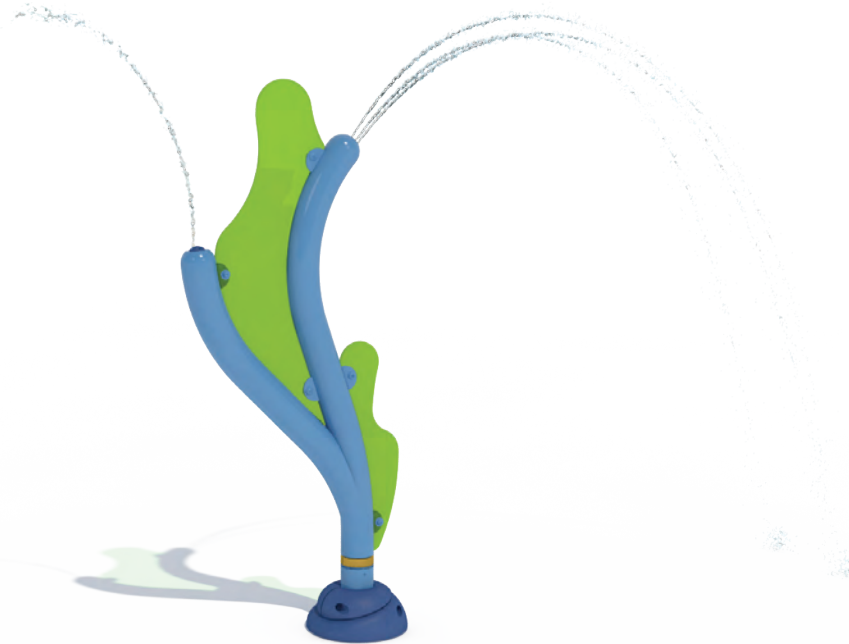

Ideal age group: 6 years and up

PRODUCT HIGHLIGHTS

- Intuitive 360° rotation with no pinch point
- Encourages interaction with other kids and promotes communicative skills
- Provides a visual experience by casting colorful shadows with the Seeflow™



This Seaweed has a cannon jet!

You may also like



• Bloom N°2 (VOR 7487)



• Sailboat N°1 (VOR 7671)



• Sea Serpent N°2 (VOR 0525)



• Turtle N°2 (VOR 7216)



World leader in aquatic play solutions with over 6,000 installations worldwide
 vortex-intl.com • info@vortex-intl.com
 1.877.586.7839 (free USA/CND) • +1.514.694.3868 (Intl.)

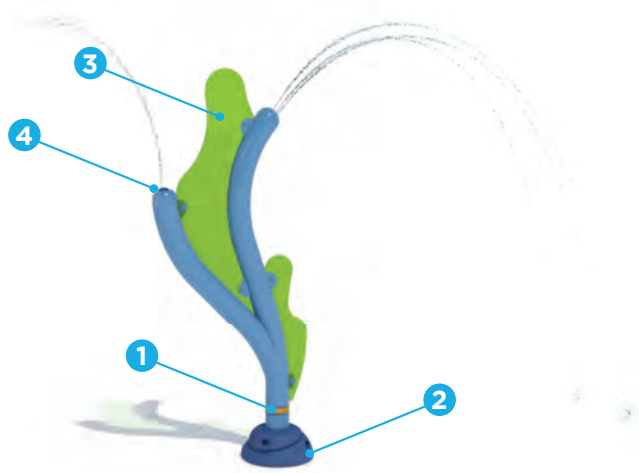

Spray Zone

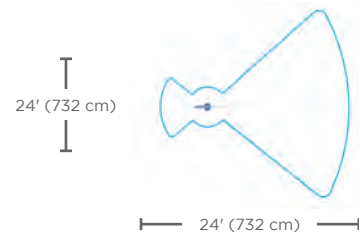

H/W/L	Pressure
57/24/11 in	5-10 PSI
145/61/28 cm	0.34-0.69 BAR

Flow	Smartflow
2-4 GPM	-
3.79-15.14 LPM	-

Color Choices: Vortex colors

VORTEX EXCLUSIVE TECHNOLOGIES

This product features the following technologies that are unique to Vortex.



TURNTEC™

- Easy turning for kids of all ages and abilities
- Lead-free brass for maximum durability - heat resistant
- 360° rotation - no mechanical stops to break
- Adjustable spray zone - control the area where water begins and stops
- Corrosion and chemical resistant



TOEGUARD™

- Soft-touch Elastomer
- Protects children's toes from anchoring hardware
- Durable, vandal resistant, resistant to chemicals
- Infused with a UV resistant bright color
- Available in one or two pieces ensuring tight fit to post



SEEFLOW™

- Impact-resistant polymer
- Resistant to UV rays and chemicals
- Colorful reflections are created with the combination of bright colors, water, and sunlight
- Manufactured with up to 40% pre-consumer recycled materials
- Reusable at the end of life



PODSPRAY™ (ON PRODUCT)

- Simply press to send water to another nozzle on the same feature
- Combine multiple pods and features to create team play
- Lead-free brass for maximum durability

WATER EFFECTS

- Cannon jet (1)
- Interactive Podspray™ (1)



World leader in aquatic play solutions with over 6,000 installations worldwide
 vortex-intl.com • info@vortex-intl.com
 1.877.586.7839 (free USA/CND) • +1.514.694.3868 (Intl.)

VORTEX

A CLEAR
SOURCE
OF
FUN

VOR 7780 SEAWEED N°2

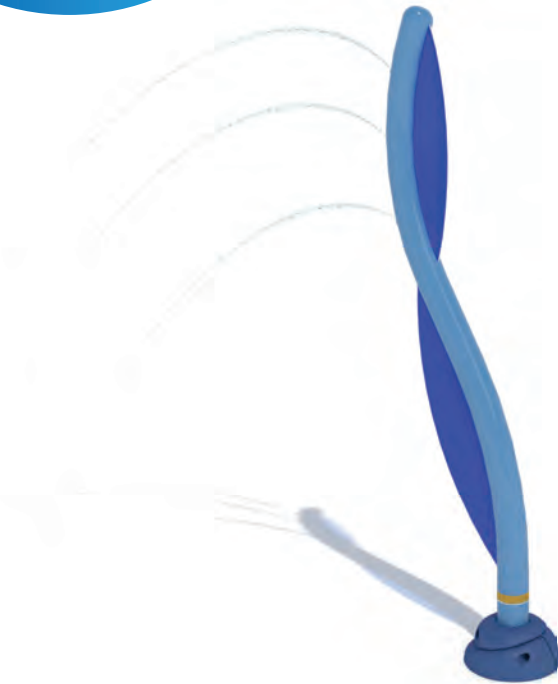

Ideal age group: 6 years and up

PRODUCT HIGHLIGHTS

- Horizontal directional water jet creating a water wall effect
- Intuitive 360° rotation with no pinch point
- Encourages interaction with other kids and promotes communicative skills
- Provides a visual experience by casting colorful shadows with the Seeflow™



This Seaweed can rotate!

You may also like



• Bloom N°1
(VOR 7486)



• Leaf N°3
(VOR 7672)



• Fish N°1
(VOR 7218)



• Bow N°1
(VOR 7673)



World leader in aquatic play solutions with over 6,000 installations worldwide
vortex-intl.com • info@vortex-intl.com
1.877.586.7839 (free USA/CND) • +1.514.694.3868 (Intl.)

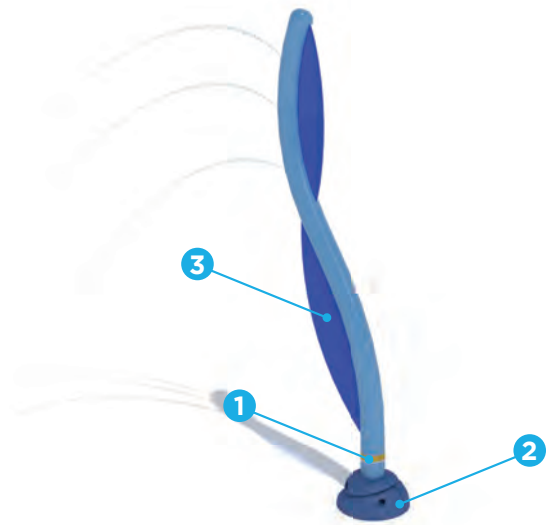

Spray Zone

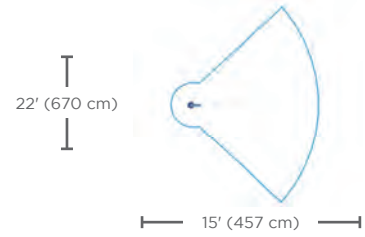

H/W/L	Pressure
73/21/11 in	5-10 PSI
184/54/27 cm	0.34-0.69 BAR

Flow	Smartflow
3-6 GPM	-
11.4-22.7 LPM	-

Color Choices: Vortex colors or polished

VORTEX EXCLUSIVE TECHNOLOGIES

This product features the following technologies that are unique to Vortex.



TURNTEC™

- Easy turning for kids of all ages and abilities
- Lead-free brass for maximum durability - heat resistant
- 360° rotation - no mechanical stops to break
- Adjustable spray zone - control the area where water begins and stops
- Corrosion and chemical resistant



TOEGUARD™

- Soft-touch Elastomer
- Protects children's toes from anchoring hardware
- Durable, vandal resistant, resistant to chemicals
- Infused with a UV resistant bright color
- Available in one or two pieces ensuring tight fit to post



SEEFLOW™

- Impact-resistant polymer
- Resistant to UV rays and chemicals
- Colorful reflections are created with the combination of bright colors, water, and sunlight
- Manufactured with up to 40% pre-consumer recycled materials
- Reusable at the end of life

WATER EFFECTS

- Jet stream (3)



World leader in aquatic play solutions with over 6,000 installations worldwide
 vortex-intl.com • info@vortex-intl.com
 1.877.586.7839 (free USA/CND) • +1.514.694.3868 (Intl.)



VORTEX
A CLEAR SOURCE OF FUN

Ideal age group: 6 years and up

VOR 0220 TUBE N°1



PRODUCT HIGHLIGHTS

- Intuitive 360° rotation with no pinch point
- Promotes communicative skills and interaction with other kids



Turn this Tube and aim!

You may also like



• Loop N°1
(VOR 7719)



• Snail N°4
(VOR 7217)



• Spray cannon
(VOR 0201)



World leader in aquatic play solutions with over 6,000 installations worldwide
vortex-intl.com • info@vortex-intl.com
1.877.586.7839 (free USA/CND) • +1.514.694.3868 (Intl.)

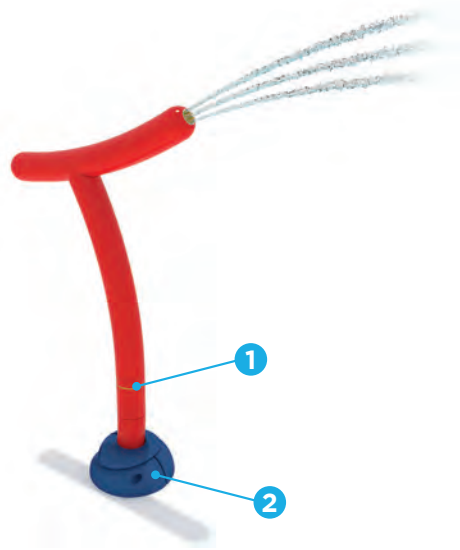

Spray Zone

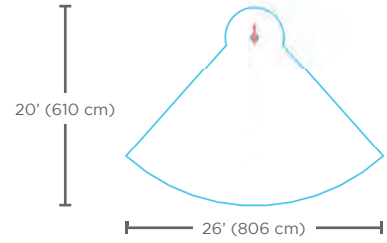

H/W/L	Pressure
-------	----------

46/11/26 in	10-15 PSI
118/27/65 cm	0.7-1 BAR

Flow	Smartflow
------	-----------

5-10 GPM	3-5 GPM
19-38 LPM	11-19 LPM

Color Choices: Vortex colors

VORTEX EXCLUSIVE TECHNOLOGIES

This product features the following technologies that are unique to Vortex.



TURNTEC™

- Easy turning for kids of all ages and abilities
- Lead-free brass for maximum durability - heat resistant
- 360° rotation - no mechanical stops to break
- Adjustable spray zone - control the area where water begins and stops
- Corrosion and chemical resistant



TOEGUARD™

- Soft-touch Elastomer
- Protects children's toes from anchoring hardware
- Durable, vandal resistant, resistant to chemicals
- Infused with a UV resistant bright color
- Available in one or two pieces ensuring tight fit to post

WATER EFFECTS

- Cannon jet (1)

Features, anchoring systems and hardware are made of 100% recyclable stainless steel, including at least 25% post-consumer recycled content.



World leader in aquatic play solutions with over 6,000 installations worldwide
 vortex-intl.com • info@vortex-intl.com
 1.877.586.7839 (free USA/CND) • +1.514.694.3868 (Intl.)



 **VORTEX**
**A CLEAR
SOURCE
OF
FUN**

Ideal age group: For all ages

VOR 0301 GROUND GEYSER



PRODUCT HIGHLIGHTS

- Exciting water effect from the ground for an immersive play
- Kids will enjoy running their hands and legs through the water



It's an explosion of water!

You may also like



• Flush Volcano
(VOR 7676)



• Foaming geyser N°2
(VOR 8084)



• Waterbug N°2
(VOR 7581)



World leader in aquatic play solutions with over
6,000 installations worldwide
vortex-intl.com • info@vortex-intl.com
1.877.586.7839 (free USA/CND) • +1.514.694.3868 (Intl.)

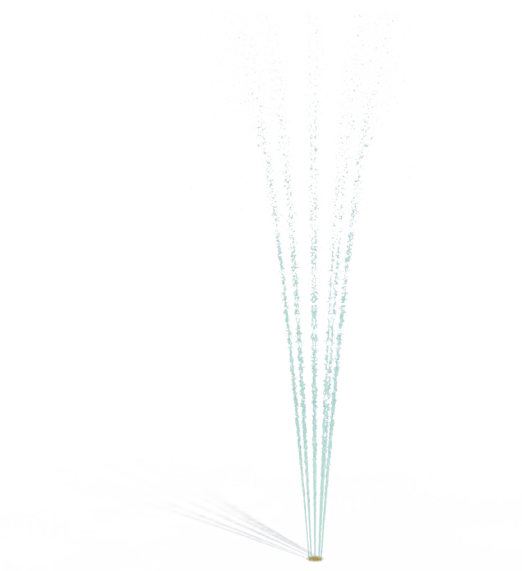

Spray Zone

ø 96" (ø 244 cm)

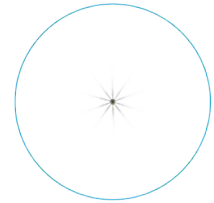

H/W/L

0/3/3 in
0/8/8 cm

Pressure

5-10 PSI
0.34-0.69 BAR

Flow

5-10 GPM
18.93-37.85 LPM

Smartflow

-
-

Color Choices: Colors as shown

WATER EFFECTS

- Jet stream (10)



• World leader in aquatic play solutions with over
• 6,000 installations worldwide
• vortex-intl.com • info@vortex-intl.com
• 1.877.586.7839 (free USA/CND) • +1.514.694.3868 (Intl.)



Ideal age group: For all ages

VOR 7032 WATER JELLY N°3

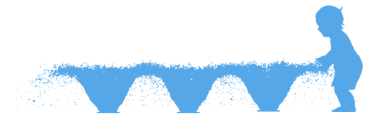

PRODUCT HIGHLIGHTS

- Encourage different play opportunities
- Kids will enjoy running their hands and legs through the water



*This Water Jelly is
three times the fun!*

You may also like



• Turtle N°2
(VOR 7216)



• Crab N°2
(VOR 7220)



• Seaweed N°2
(VOR 7780)



• Scorpion
(VOR 7652)



World leader in aquatic play solutions with over
6,000 installations worldwide
vortex-intl.com • info@vortex-intl.com
1.877.586.7839 (free USA/CND) • +1.514.694.3868 (Intl.)



Spray Zone

ø 72" (ø 183 cm)

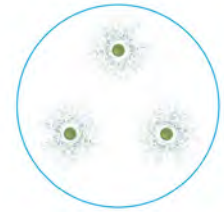

H/W/L

0/36/42 in
0/91/107 cm

Pressure

1-2 PSI
0.07-.014 BAR

Flow

30-35 GPM
113.6-132.5 LPM

Smartflow

-
-

Color Choices: Colors as shown

WATER EFFECTS

- Inverted Bell Spray (3)



World leader in aquatic play solutions with over
6,000 installations worldwide
vortex-intl.com • info@vortex-intl.com
1.877.586.7839 (free USA/CND) • +1.514.694.3868 (Intl.)



VORTEX
A CLEAR SOURCE OF FUN

Ideal age group: 4 years and up

VOR 7640 TEAM SPRAY N 1

PRODUCT HIGHLIGHTS

- Exciting burst of water for many play opportunities
- Engage with this feature by increasing water flow with the ground Podsprays™
- Enjoy running through the water jets

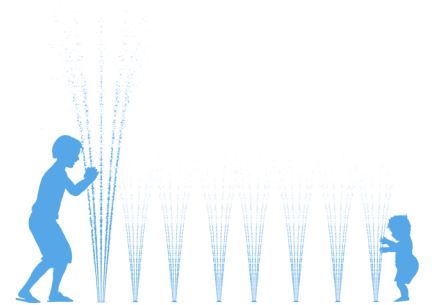

This feature will spray you!

You may also like

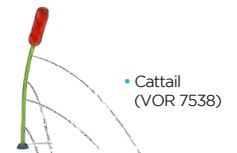
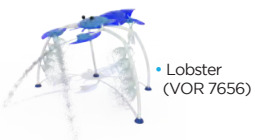

World leader in aquatic play solutions with over 6,000 installations worldwide
vortex-intl.com • info@vortex-intl.com
1.877.586.7839 (free USA/CND) • +1.514.694.3868 (Intl.)

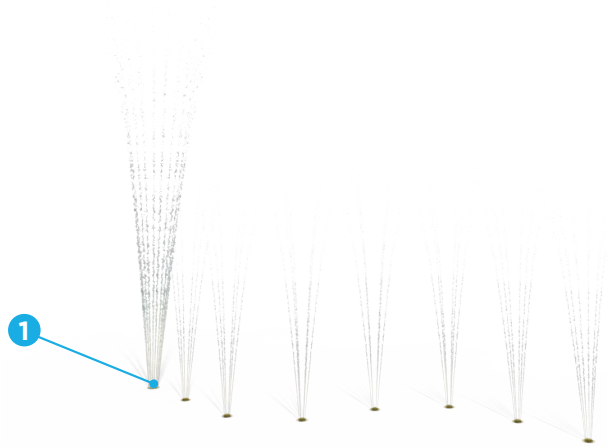

Spray Zone

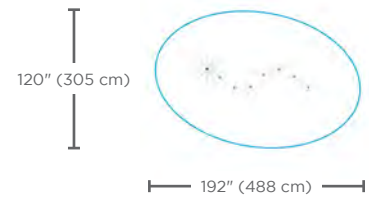

H/W/L	Pressure
1.1/44/93 in	1-10 PSI
3/112/236 cm	0.07-0.69 BAR

Flow	Smartflow
15-20 GPM	-
56.8-75.7 LPM	-
Color Choices: Colors as shown	

VORTEX EXCLUSIVE TECHNOLOGIES

This product features the following technologies that are unique to Vortex.



PODSPRAY™ (GROUND)

- Simply step on or press to send water to another feature
- Increase flow to attached features to increase play value - connected features spin faster, spray farther, dance higher
- Combine multiple pods and features to create team play
- Lead-free brass for maximum durability

WATER EFFECTS

- Interactive Podspray™ (7)
- Jet stream (10)



World leader in aquatic play solutions with over 6,000 installations worldwide
 vortex-intl.com • info@vortex-intl.com
 1.877.586.7839 (free USA/CND) • +1.514.694.3868 (Intl.)



VORTEX
A CLEAR SOURCE OF FUN

Ideal age group: For all ages

VOR 8061 TEAM SPRAY N°2

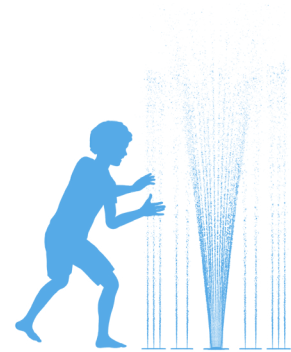

PRODUCT HIGHLIGHTS

- Activate this feature by pressing on the Funflow Actuator™
- Exciting burst of water for many play opportunities
- Enjoy running through the water jets



Immerse in this feature

You may also like



• Cylinder Spray (VOR 0307)



• Frog N°4 (VOR 7203)



• Leaf N°3 (VOR 7672)



• Turtle N°2 (VOR 7216)



World leader in aquatic play solutions with over 6,000 installations worldwide
 vortex-intl.com • info@vortex-intl.com
 1.877.586.7839 (free USA/CND) • +1.514.694.3868 (Intl.)

Spray Zone

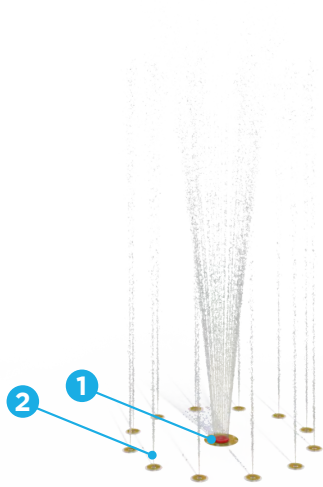

ø 180" (ø 457 cm)

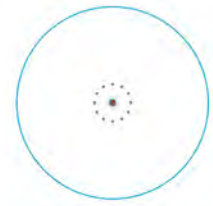

H/W/L

0.75/38/38 in
2/97/97 cm

Pressure

5-15 PSI
0.34-1.03 BAR

Flow

36-60 GPM
75.7-181.7 LPM

Smartflow

-
-

Color Choices: Colors as shown

VORTEX EXCLUSIVE TECHNOLOGIES

This product features the following technologies that are unique to Vortex.



FUNFLOW ACTUATOR™

- Interactive cause & effect
- Encourages Collaborative Play
- Step on the cap to divert and multiply the water to another feature
- Low flow when not pressed to help save water
- No electrical required - simple installation



LINEFLOW^{MC} NOZZLE

- Precisely orient the stream of water with the internal Brass marble
- Compact design provides better product integration
- Easy to adjust for the most efficient use of water based on your installation
- Made of lead-free brass for maximum durability

WATER EFFECTS

- Funflow Actuator™ Geyser (1)
- Jet stream (12)



World leader in aquatic play solutions with over
6,000 installations worldwide
vortex-intl.com • info@vortex-intl.com
1.877.586.7839 (free USA/CND) • +1.514.694.3868 (Intl.)



VORTEX
**A CLEAR
 SOURCE
 OF
 FUN**

Ideal age group: For all ages

VOR 0305 DIRECTIONAL WATER JET

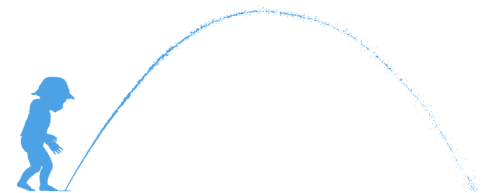

PRODUCT HIGHLIGHTS

- Provides high interactivity with low water consumption
- Offers many play opportunities



Play with this Jet!

You may also like



• Volcano Flush
 (VOR 7676)



• Cylinder Spray
 (VOR 0307)



• Frog N°2
 (VOR 7201)



World leader in aquatic play solutions with over
 6,000 installations worldwide
vortex-intl.com • info@vortex-intl.com
 1.877.586.7839 (free USA/CND) • +1.514.694.3868 (Intl.)

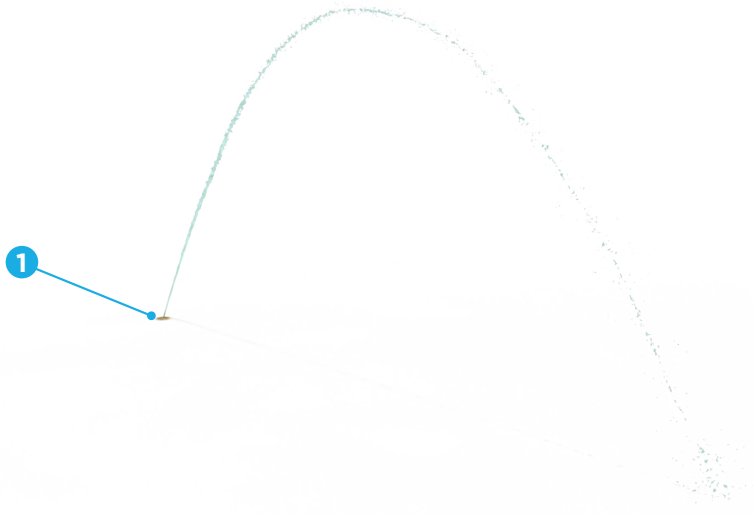

Spray Zone

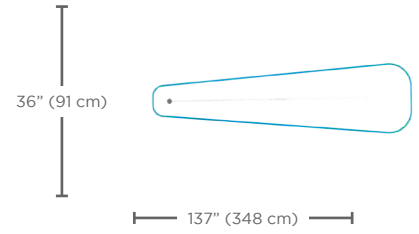

H/W/L	Pressure
-------	----------

0/3/3 in	5-10 PSI
0/8/8 cm	0.34-0.69 BAR

Flow	Smartflow
------	-----------

3-5 GPM	-
11.36-18.93 LPM	-

Color Choices: Colors as shown

VORTEX EXCLUSIVE TECHNOLOGIES

This product features the following technologies that are unique to Vortex.



LINEFLOW™ NOZZLE

- Precisely orient the stream of water with the internal Brass marble
- Compact design provides better product integration
- Easy to adjust for the most efficient use of water based on your installation
- Made of lead-free brass for maximum durability

WATER EFFECTS

- Ground directional jet (1)



World leader in aquatic play solutions with over 6,000 installations worldwide
 vortex-intl.com • info@vortex-intl.com
 1.877.586.7839 (free USA/CND) • +1.514.694.3868 (Intl.)



 **VORTEX**
**A CLEAR
SOURCE
OF
FUN**

Ideal age group: For all ages

VOR 7512 JET STREAM



PRODUCT HIGHLIGHTS

- Enjoy running your feet and hands in this feature
- Provide high interactivity with low water consumption



*This Jet will amuse
you!*

You may also like



• Snake N°2
(VOR 7214)



• Loop N°1
(VOR 7719)

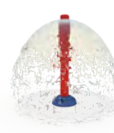

• Aqua Dome N°1
(VOR 0555)



World leader in aquatic play solutions with over
6,000 installations worldwide
vortex-intl.com • info@vortex-intl.com
1.877.586.7839 (free USA/CND) • +1.514.694.3868 (Intl.)



Spray Zone

ø 60" (ø 152 cm)

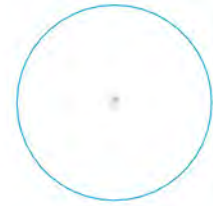

H/W/L

0/6/6 in
0/15/15 cm

Pressure

5-10 PSI
0.34-0.69 BAR

Flow

2-3 GPM
7.57-11.36 LPM

Smartflow

-
-

Color Choices: Colors as shown

VORTEX EXCLUSIVE TECHNOLOGIES

This product features the following technologies that are unique to Vortex.

1



LINEFLOW^{MC} NOZZLE

- Precisely orient the stream of water with the internal Brass marble
- Compact design provides better product integration
- Easy to adjust for the most efficient use of water based on your installation
- Made of lead-free brass for maximum durability

WATER EFFECTS

- Jet stream (1)



World leader in aquatic play solutions with over
6,000 installations worldwide
vortex-intl.com • info@vortex-intl.com
1.877.586.7839 (free USA/CND) • +1.514.694.3868 (Intl.)



 **VORTEX**
**A CLEAR
SOURCE
OF
FUN**

Ideal age group: 4 years and up

VOR 0613 **ACTIVATOR N° 2**



PRODUCT HIGHLIGHTS

- Enables to activate the water sequence of play features
- Controls water consumption and helps reduce waste



World leader in aquatic play solutions with over
6,000 installations worldwide
vortex-intl.com • info@vortex-intl.com
1.877.586.7839 (free USA/CND) • +1.514.694.3868 (Intl.)

Top View

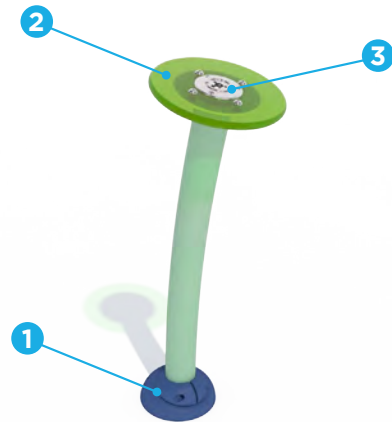

H/W/L	Pressure
-------	----------

39/13/17 in
99/33/43 cm

0 PSI
0 BAR

Flow	Smartflow
------	-----------

0 GPM
0 LPM

-
-

Color Choices: Vortex colors or polished

VORTEX EXCLUSIVE TECHNOLOGIES

This product features the following technologies that are unique to Vortex.



TOEGUARD™

- Soft-touch Elastomer
- Protects children's toes from anchoring hardware
- Durable, vandal resistant, resistant to chemicals
- Infused with a UV resistant bright color
- Available in one or two pieces ensuring tight fit to post



SEEFLOW™

- Impact-resistant polymer
- Resistant to UV rays and chemicals
- Colorful reflections are created with the combination of bright colors, water, and sunlight
- Manufactured with up to 40% pre-consumer recycled materials
- Reusable at the end of life



PRESS & PLAY ACTIVATOR

- On-demand activation saves water
- Constructed of durable stainless steel - vandal resistant
- No moving parts
- Low voltage - safe fun
- 2 wire connection - easy installation
- Easy operation - for kids of all ages & abilities



World leader in aquatic play solutions with over
6,000 installations worldwide
vortex-intl.com • info@vortex-intl.com
1.877.586.7839 (free USA/CND) • +1.514.694.3868 (Intl.)



Playsafe Drain N° 1

With its blue color, this industrial strength drain is both visually pleasing and functional by preventing the build-up of pooling water on the Splashpad®. This drain suits all size Splashpads®

Playsafe Drain N° 1				VOR 1001.4000
Product H/W/L	Pressure	Flow	Smart Flow	Spray Zone W/L
16 / 30 / 30 in	–	–	–	–
41 / 76 / 76 cm	–	–	–	–
Material: Stainless steel				
Action: Drain				



WATER MANAGEMENT SOLUTIONS

DRIVEN BY SMARTFLOW™ TECHNOLOGY

Water management is a vital component to the success of an aquatic play project.

With options for any size, Vortex water management solutions are specifically engineered for your project. Vortex provides a range of sustainable water management solutions with the best operating efficiency and the highest standards of water quality in the industry. Vortex water management solutions meet and exceed all regional and environmental standards and regulations.

Vortex offers water management training and service plans.



WATER MANAGEMENT COMPONENTS

Vortex water management solutions feature Smartflow™ technology. This technology comprises of control systems that orchestrate water flow to play products based on sequences and timing, high efficiency nozzles that maintain fun while optimizing water usage, and on-demand activators that ensure that water is only flowing when the products are in use.

Together these elements combine to provide an efficient, eco-sensitive solution.

ON-DEMAND ACTIVATION



- On-demand means less water by turning water on only when users press the activator
- Robust construction with no moving parts
- Easy operation for kids of all ages & abilities

PLAYSAFE™ DRAIN

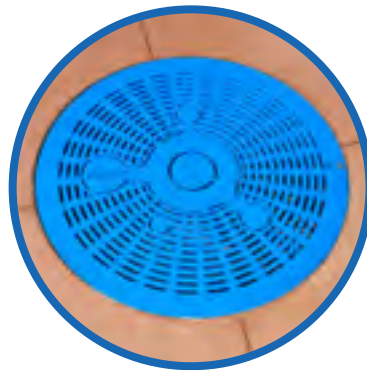

- Primary filter of debris
- Safe for small toes and skid resistant
- Stainless steel construction and high flow rate capacity

DEBRIS AND RAINWATER CONTROL



- Strains the effluent water prior to entering the Water Containment System for a cleaner reservoir and reduced maintenance
- Rainwater Control maintains water balance and prevents chemical waste by diverting rainwater

WATER CONTAINMENT SYSTEM



- Provides underground water storage
- Constructed of durable, long-lasting reinforced polymer
- Equipped with a lockable access hatch, access ladder, piping connections, make-up water system and check valves

COMMAND CENTERS



SMARTPOINT™ ALL-IN-ONE

- Cost effective control solution for Splashpad® or Spraypoint®
- Combines foot activator, controller, water distribution system and drain for simplified operation
- Used with flow-through, reuse or recirculation systems

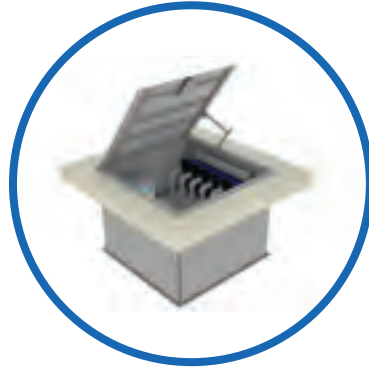

EQUIPMENT VAULT

- Durable self-enclosed below-grade enclosure to keep equipment out-of-sight
- Stainless steel access hatch and step-down grate for easy access



EQUIPMENT CABINET

- Self-enclosed system with easy access to controller and valves
- Stainless steel frame construction for protection against vandalism and corrosion



WALL MOUNTED

- Ideal for housing inside an existing building
- Preassembled system with mounting brackets for easy installation

WATER QUALITY MANAGEMENT OPTIONS



State-of-the-art water filtration and disinfection system complete with a control command center and energy efficient equipment.



DOMEPACK

- Self-enclosed compact solution with low profile design that discreetly blends into the surrounding environment
- Durable construction protects against weather and vandalism



SKIDPACK

- Flexible solution configured to adapt to an existing building and fit into any space
- Three separate pieces: feature loop, filter loop and controller which are connected and installed onsite

MAESTRO

INTELLIGENT WATER CONTROL

MAESTRO ENABLES FULL CONTROL OF MULTIPLE WATER PLAY AND DISPLAY SOLUTIONS FROM A REMOTE LOCATION TO CREATE UNIQUE-EXPERIENCES.

FEATURES & BENEFITS

MAESTROLINK™ SOFTWARE

- Remote access for maintenance and operation reduces onsite visits
- Easy sequence modification and playlist creation remotely or onsite
- Online technical support direct from Vortex

VISUAL INTERFACE

- Simple user interface for intuitive control
- Real time 3D simulation of features on 10" color screen

POWERFUL PROCESSING

- Advanced custom sequencing capabilities
- Control endless amounts of features with various timing and sequencing patterns

RESOURCE MANAGEMENT

- Real-time flow control for efficient energy and water usage
- Reduction of water hammer issues through soft start/stop transitions within sequences

3G CONNECTION

- Industrial-grade cellular router kit option eliminates need for a hard network cable

MAESTRO LIGHT

- Option to synchronize LED lighting and water to create stunning choreography

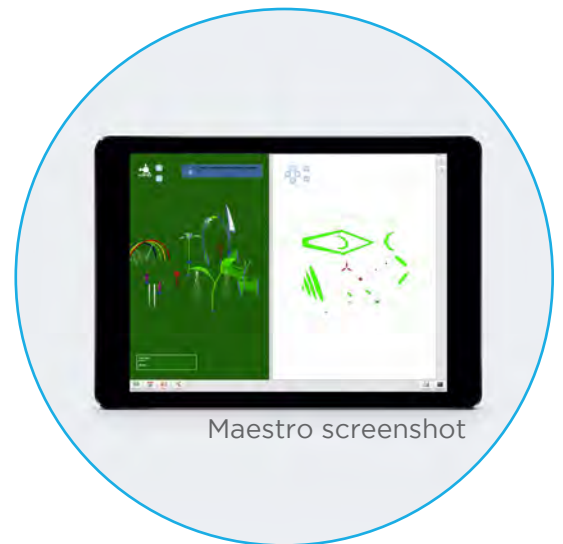

World leader in aquatic play solutions with over
6,000 installations worldwide
vortex-intl.com • info@vortex-intl.com
1.877.586.7839 (free USA/CND) • +1.514.694.3868 (INTERNATIONAL)

WATER CONTAINMENT SYSTEM

WATER MANAGEMENT SYSTEM FOR HIGHFLOW SPLASHPAD®

In a recirculating Splashpad®, the water is stored in a subterranean reservoir. The Vortex vessel has been engineered specifically for usage within the WQMS Splashpad® configuration. Its fiber reinforced polymer construction generates structural integrity, while remaining impermeable and corrosion resistant, minimizing leaching and chemical consumption. The Vortex Water Containment System arrives on site ready for installation and includes flanged connections, integrated check valves, automated water level control system, lockable access hatch and a pre-installed corrosion resistant access ladder to provide safe operation and easy maintenance.

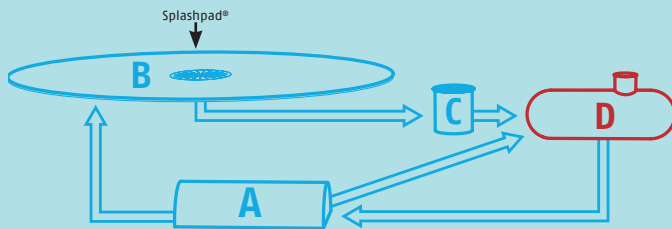

- A) Water Quality Management System (WQMS)
- B) Playsafe Drain
- C) Debris Control System (DCS) with Rain Control System (RCS)
- D) Water Containment System (WCS)

Figure 1. ILLUSTRATION OF WATER CIRCULATION AND SUBSYSTEMS OF THE WMS

Highlights

- White interior facilitates visual inspections
- Lockable access hatch and integrated ladder facilitates access
- Automated refill system for make-up water, ensure proper water levels
- Includes anchors and anchor straps to ensure proper installation
- Integrated plumbing connection points to facilitate installation
- Check valves included in the reservoir
- Chemical distribution manifold at the bottom of reservoir

Specifications

Reservoir material:	Fiber Reinforced Polymer
Access size:	30 inches (762 mm)
Ladder material:	Fiber Reinforced Polymer
Overflow line:	Connects to the sanitary system
Anchoring straps :	Secure resevoir in place
Access hatch:	Aluminium

Product no.	Model	Total Capacity (gal/l)	Diameter (ft/m)	Length (ft/m)
VOR 5312	WCS 2,000	2,000 / 7,750	6 / 2	12 / 3.7
VOR 5311	WCS 3,000	3,000 / 11,356	6 / 2	17 / 5.1
VOR 5313	WCS 4,000	4,000 / 15,142	6 / 2	21 / 6.5



DEBRIS CONTROL SYSTEM WITH OPTIONAL RAIN CONTROL SYSTEM

When Splashpads® are installed in landscaped areas surrounded by trees, grass and landscaping material such as wood mulch, there is a risk of debris finding its way on to the Splashpad® and into the recirculation system. Excessive debris can create higher maintenance costs and may cause damage to some equipment. The Vortex Debris Control System (DCS) provides an effective way to reduce the level of debris flowing back into the water management system. The DCS is installed to intercept the water flowing from the Splashpad® prior to it entering the Water Containment System (WCS). Water exiting the DCS has been screened of debris larger than the average size of a grain of rice. The DCS offers a primary screening process providing:

- Cleaner Water Containment System
- Less backwashing and cleaning of strainers
- Reduction in blockage of valves and spray nozzles on Water Features
- Less chemical consumption
- Longer lifespan on mechanical equipment
- And ultimately, less maintenance

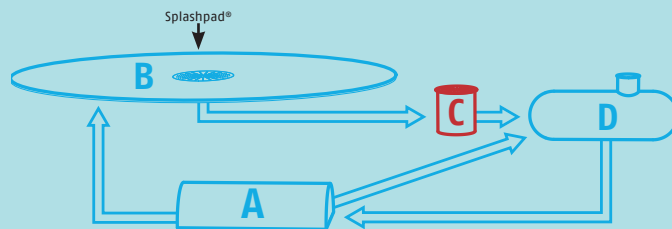

- A) Water Quality Management System (WQMS)
- B) Playsafe Drain
- C) Debris Control System (DCS) with Rain Control System (RCS)
- D) Water Containment System (WCS)

Figure 1. ILLUSTRATION OF WATER CIRCULATION AND SUBSYSTEMS OF THE WMS

Rain Control System (Optional)

VOR-532

Rain water falling onto the Splashpad® will flow into the Water Quality Management System. To minimize the influx of rain water into the water management system, the Rain Control System (RCS) can be integrated into the Debris Control System. Outside operational hours, the RCS will redirect rain to the municipal storm water system providing

- Prevention of storm water flowing to sanitary system
- Helps chemically treated water from overflowing and being wasted
- Less chemical consumption
- Reduction of overflow and wastage of chemically treated water

Specifications

- High Density Polyethene vessel
- Stainless steel strainer-basket and hardware
- Anodized aluminum access hatch with locking system
- DCS mesh screens particles as small as 0.05 inch (1.3mm)
- Inlet connection: 10 inches (25 cm)
- Outlet connection: 10 inches (25 cm)
- Storm water drain connection: 4 inches (10.2 cm)
- Motorized valve: IP 67 water proof
- Dust proof with built-in thermal protection

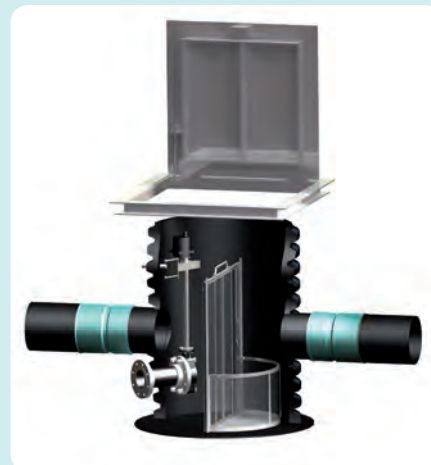

WATER QUALITY MANAGEMENT SYSTEM: SKIDPACK

WATER AND ENERGY CONSERVATION BUILT-IN

Vortex Water Quality Management Systems (WQMS) are specifically engineered and constructed to handle the heavy usage that Splashpad® need to endure. Vortex offers several WQMS models to accommodate various flow rates, heal and safety codes with special features that significantly reduce water and energy consumption. Vortex WQMS incorporate only high quality commercial grade components to ensure the most reliable system and backed by an industry leading warranty.

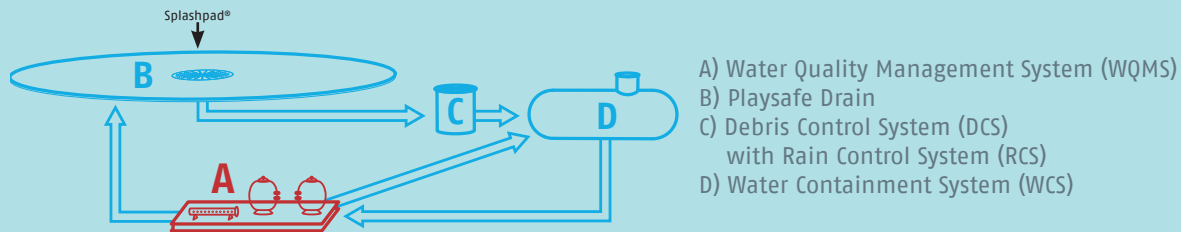

Figure 1. ILLUSTRATION OF WATER CIRCULATION AND SUBSYSTEMS OF THE WMS

The Vortex Skidpack

The Vortex Water Quality Management System (WQMS) consists of these sub-systems:

A. Water Distribution System (WDS)

Distributes the water to the play features on the Splashpad®. Both flow and water pressure can be adjusted to optimize the operation of each independent spray feature. The primary components of the WDS are:

- **Stainless steel manifold** provides the structural backbone to resist water hammer and vibration.
- **Solenoid valves** are connected to the system controller to create spray sequences.
- **Circulation pump** provides the power to move the water through the system.
- **By-pass system** protects the circulation pump from dead heading.

B. Filtration System

Removes organic and/or inorganic suspended particles from the water. The filters used are commercial grade, high rate, sand media filters. Incorporating the Vortex Debris Control System will provide a primary screening of larger particles prior to entering the sand filters, resulting in less backwashing, water use and ultimately, maintenance.

C. Automation and Control Systems

Provide play feature sequencing, operational time control, water flow and water quality monitoring and adjustment.

The primary components consist of:

- **Smart Touch Logics Controller** controls the operational hours, spray sequences and interfaces with the motor starters and chemical controller to respond to any alarm conditions.
- **Water Chemistry Controller**, see Sanitization system.
- **Variable frequency drives** for pumps regulate water pressure, flow and reduce energy consumption.
- **Flow meters** provide readings on filtration rates and circulation rates to ensure proper operation and are mandated by most health regulations.

D. Sanitization System

Contributes to providing healthy water conditions for the safe operation of Splashpads®. The main components consist of:

- **Water Chemistry Controller** provides continuous monitoring and adjustments of chemical additions to manage a balanced water chemistry. When chemicals are imbalanced, the controller sets off an signal indicating conditions are outside of safe parameters.
- **Chemical Feed System** comes with injection pumps and liquid chemicals or a chlorinator, such as the alternative chemical dosing system.
- **Chemical containment resevoir** offered in below-grade or above-grade options for liquid chlorine and muriatic acid systems.
- **Ultraviolet system**, this optional UV light disinfection provides added protection against nuisance micro organisms – such as Cryptosporidium Parvuum – in water. The system is integrated into the Vortex WQMS to provide proper compatibility and smooth operation.

The **Skidpack system** comes prewired, mounted and fully assembled on a fiber reinforced polymer platform that provides a durable, clean and dry environment. With a recommended space of at least three feet (0,9 m) around for easy access and maintenance to equipment, the Vortex WQMS Skidpack is an effective solution for public parks or environments that have an existing building to house the system.

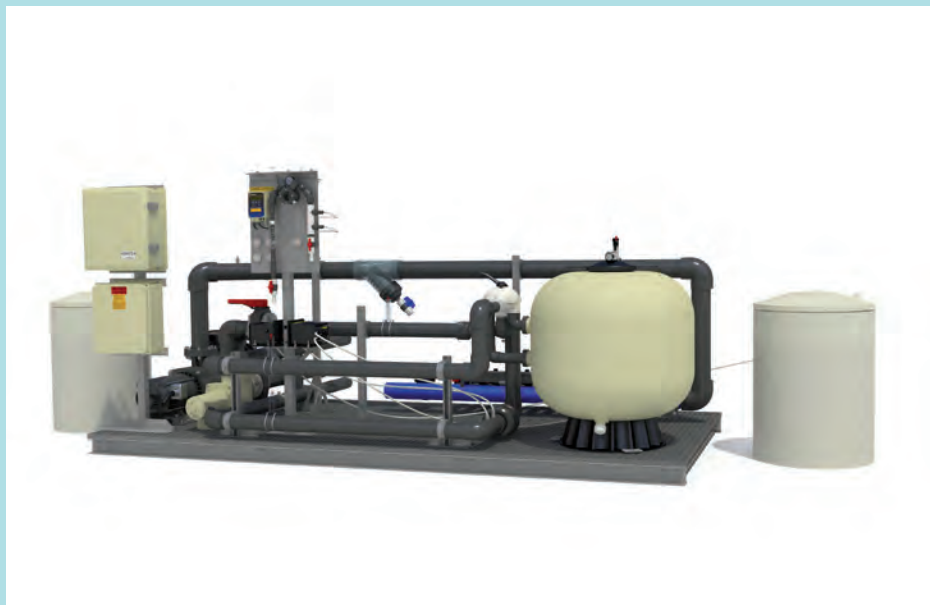

Industry Leading Warranty all standard Skidpack and Domepack systems are backed by a comprehensive warranty.

Training and Start-up programs

As with all recreational water treatment systems, the Vortex WQMS requires a daily maintenance by trained staff. Vortex offers training programs and system start-up services to ensure the successful implementation and operation of your system. Please inquire about these services with Vortex or our local representative.

Vortex offers Optional Service Plans & Training

- Vortex Premium Service Plan
- Vortex Certified Maintenance Program
- Vortex Certified Training Program





- Chase Lounge
\$25K

- Concession/Restroom
Drinking Fountain
Shower

Estimate \$240K
Installed

- (6) 20' Umbrellas
\$35K Installed

- Polygon Rental
Shelter
\$90K Installed

- Recirculation
System
Shelter
\$10K Installed

- Extra concrete
Deck
\$80K

- Fence
\$25K

- Picnic Tables
Installed
\$25K

Estimated \$600K +
Vortex

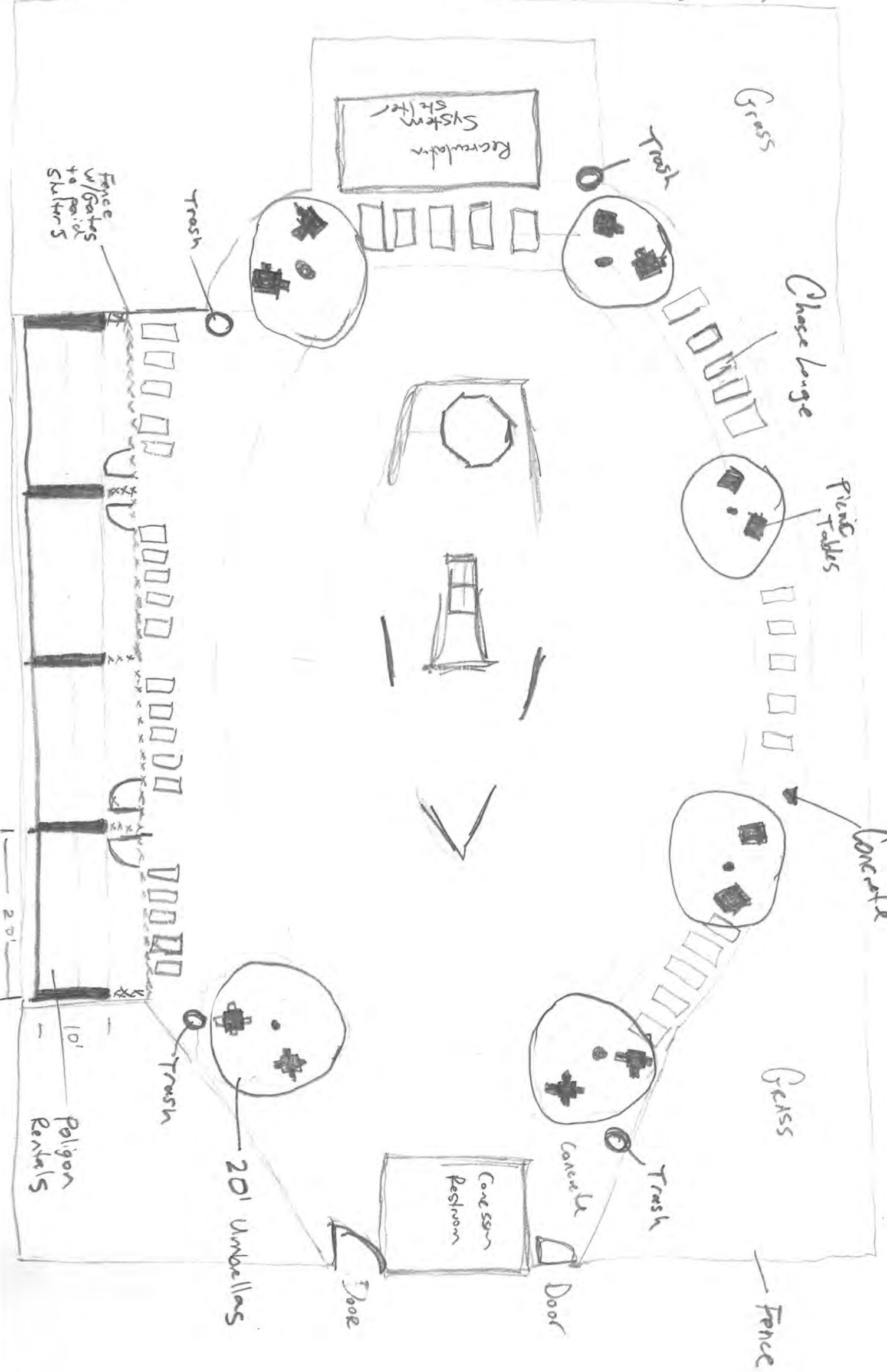

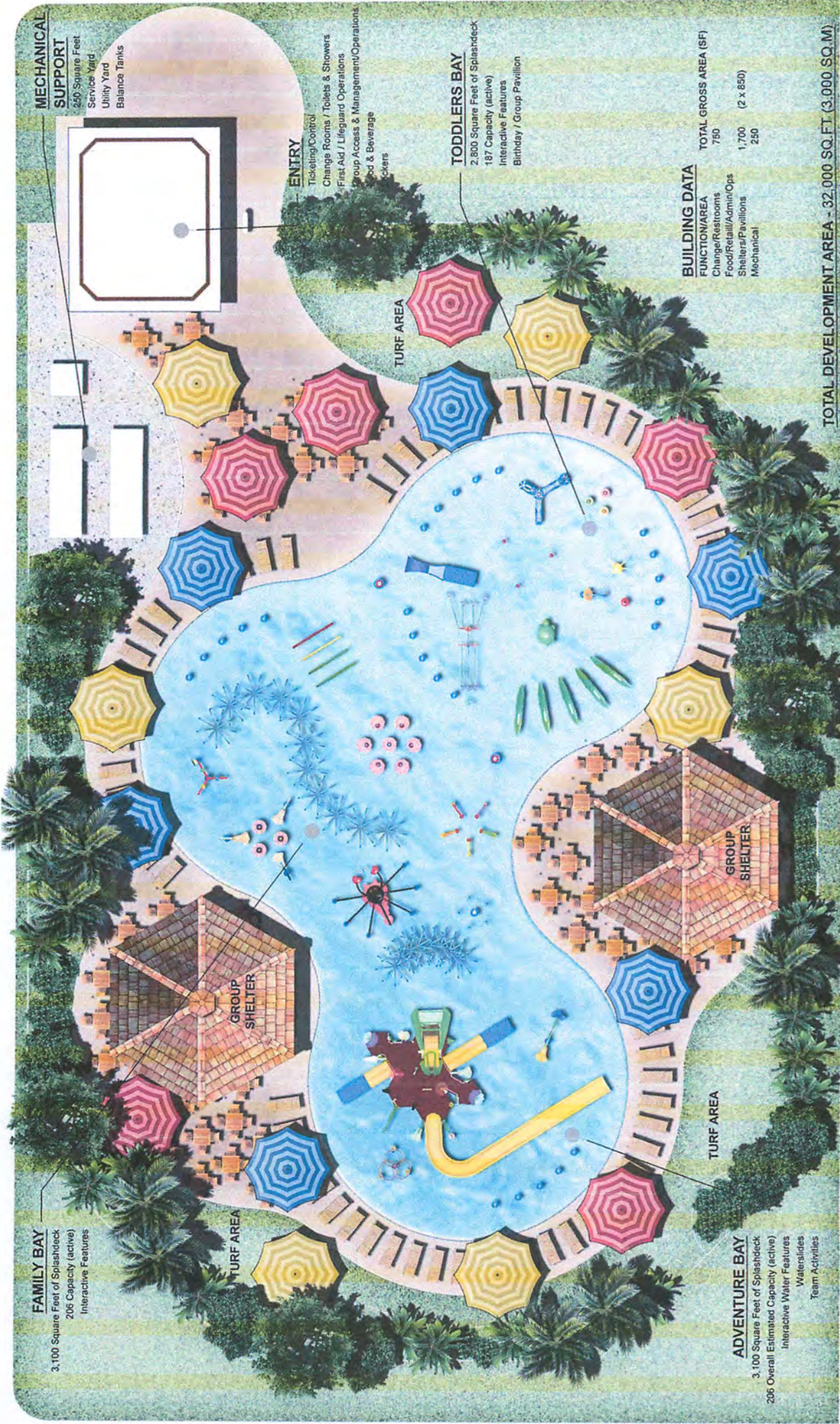

FAMILY BAY
 3,100 Square Feet of Splashdeck
 206 Capacity (active)
 Interactive Features

MECHANICAL SUPPORT
 240 Square Feet
 Service Yard
 Utility Tanks
 Balance Tanks

ENTRY
 Ticketing/Control
 Change Rooms / Toilets & Showers
 First Aid / Lifeguard Operations
 Group Access & Management/Operations
 Food & Beverage
 Lockers

TODDLERS BAY
 2,800 Square Feet of Splashdeck
 187 Capacity (active)
 Interactive Features
 Birthday / Group Pavilion

BUILDING DATA

FUNCTION/AREA	TOTAL GROSS AREA (SF)
Change/Restrooms	750
Food/Retail/Admin/Ops	1,700 (2 x 850)
Shelters/Pavilions	250
Mechanical	

ADVENTURE BAY
 3,100 Square Feet of Splashdeck
 206 Overall Estimated Capacity (active)
 Interactive Water Features
 Waterslides
 Team Activities

TOTAL DEVELOPMENT AREA - 32,000 SQ.FT. (3,000 SQ.M.)

CONCEPTUAL LAYOUT

600-900 CAPACITY WATER PARK
 SPG 2013-0003 2013



SCALE: NTS
 1" = 1' - Above site

CONCEPTUAL LAYOUT. THIS CONCEPTUAL LAYOUT IS FOR INFORMATIONAL PURPOSES ONLY AND IS NOT A CONTRACT DOCUMENT. THE DESIGN AND CONSTRUCTION OF THIS WATER PARK WILL BE DETERMINED BY THE CLIENT AND THE DESIGNER. THE DESIGNER SHALL BE RESPONSIBLE FOR OBTAINING ALL NECESSARY PERMITS AND APPROVALS FROM THE LOCAL, STATE, AND FEDERAL AUTHORITIES. THE DESIGNER SHALL BE RESPONSIBLE FOR OBTAINING ALL NECESSARY PERMITS AND APPROVALS FROM THE LOCAL, STATE, AND FEDERAL AUTHORITIES.

- QUANTITIES**
- 141 - Adirondack Chairs
 - 78 - Stroller Parking
 - 75- Chaise Lounges
 - 66 - Tea Tables (18" round)
 - 19 - Large Umbrellas
 - 5 - Cabanas (10'x10')
 - 1 - Cabana for Food Service (10'x10')
 - 3 - Tables with Umbrellas
 - 60 - Seatwall Seating (181 LF)
 - 9 - Trash Receptacles

Total Seating Capacity - 288

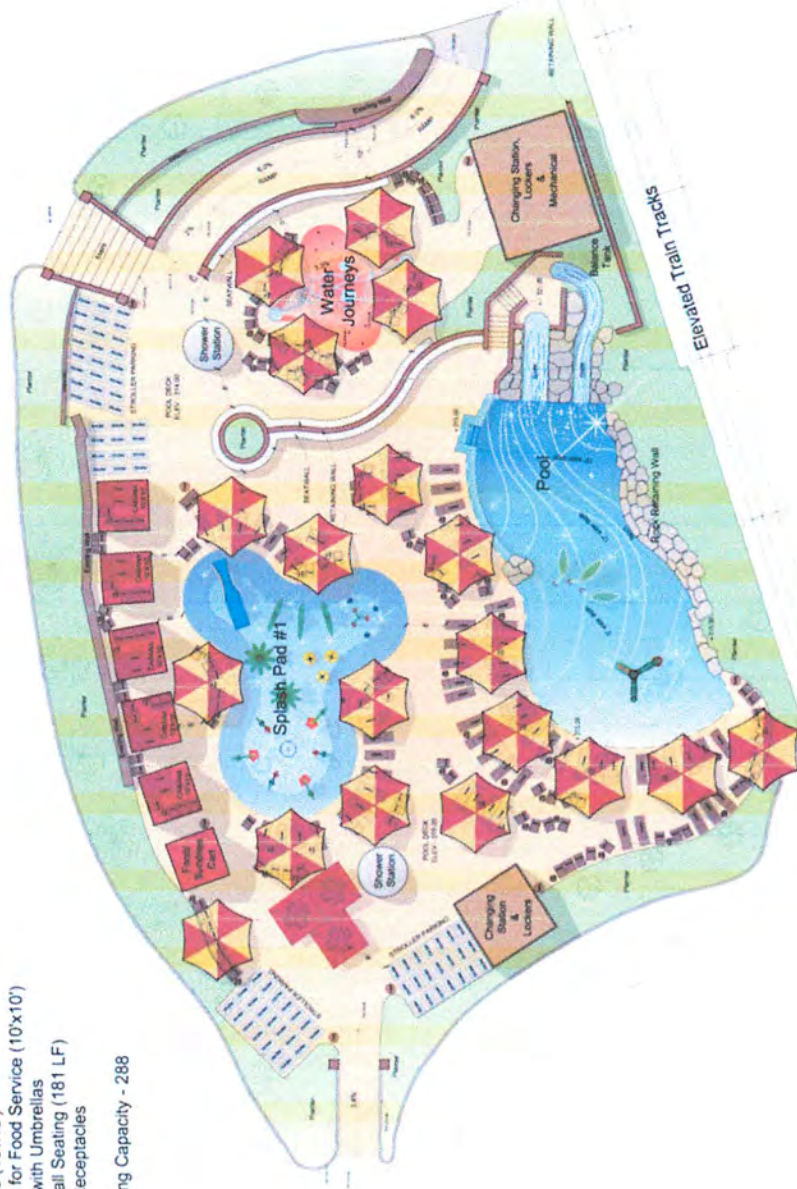

Concept 3
GILROY GARDENS
 City of Gilroy, California



HERSCHER ASSOCIATE, INC.
 LANDSCAPE ARCHITECTURE & PLANNING
 1111 EAST BROADWAY, SUITE 200
 SAN JOSE, CALIFORNIA 95128
 TEL: (415) 435-1111 FAX: (415) 435-1112

July 16, 2013

Scale 1" = 10'

saung (181 LF)
lactée

apartilly - 286



- A Bamboo No 6
- B Saung
- C Flower No 1
- D Flower No 2
- E Aquatic Flower No. 2
- F Palm Tree
- G Palm Tree
- H Team Spray No. 1
- I Team Spray No. 2
- J Sunrises
- K Water Spray
- L Boland Activator No. 2

VOR 7025 (2x FUTURE)
VOR 7026 (FUTURE)
VOR 6564 (FUTURE)
VOR 7569 (FUTURE)
VOR 1321 (1x FUTURE)
VOR 0510
VOR 8001
VOR 1118
VOR 5099
VOR 7399

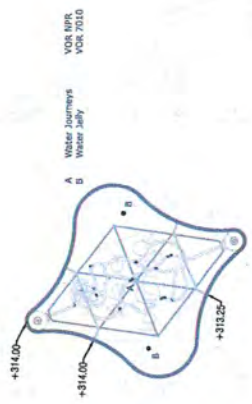

VOR 698
VOR 7010

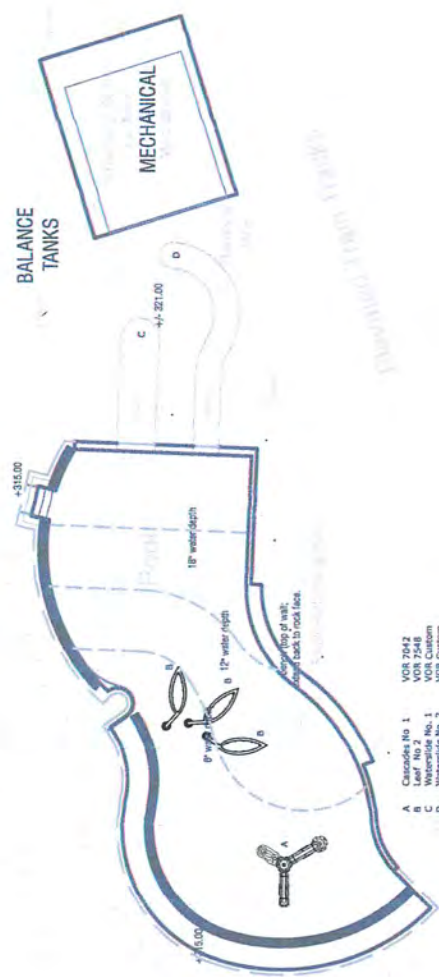

- A Cascade No. 1
- B Leaf No. 2
- C Waterfall No. 1
- D Waterfall No. 2

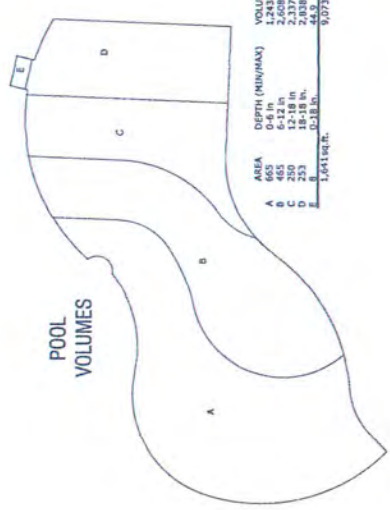

AREA	DEPTH (MIN/MAX)	VOLUME
A	6-9 ft	2,248.5
B	6-9 ft	2,248.5
C	12-18 ft	2,337.5
D	18-18 ft	2,038.6
E	0-18 ft	0.0
TOTAL		9,073.1 gallons

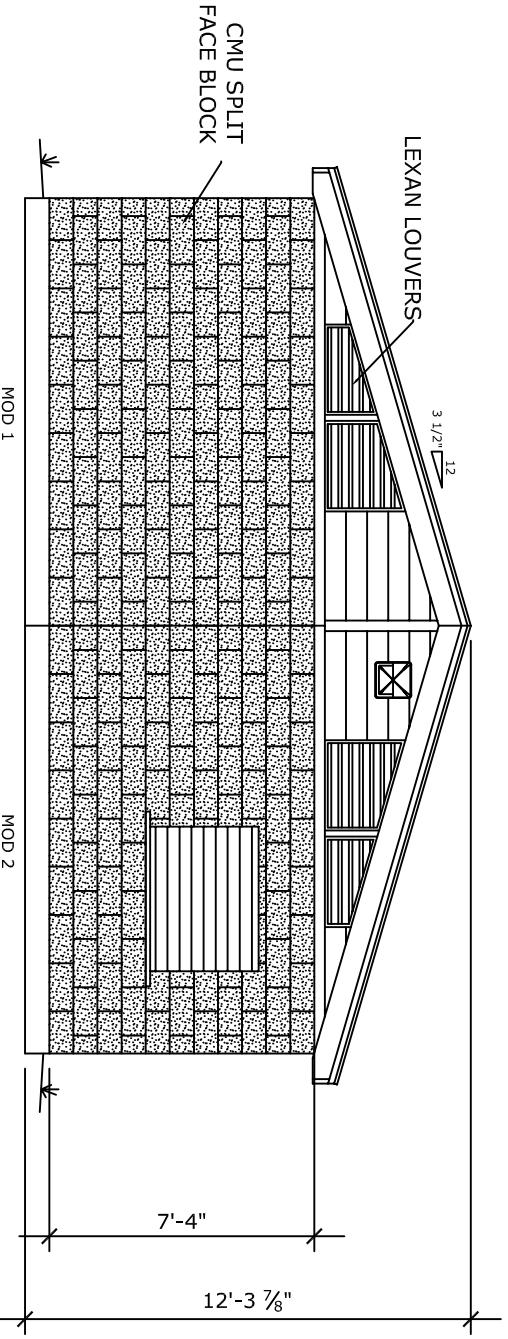
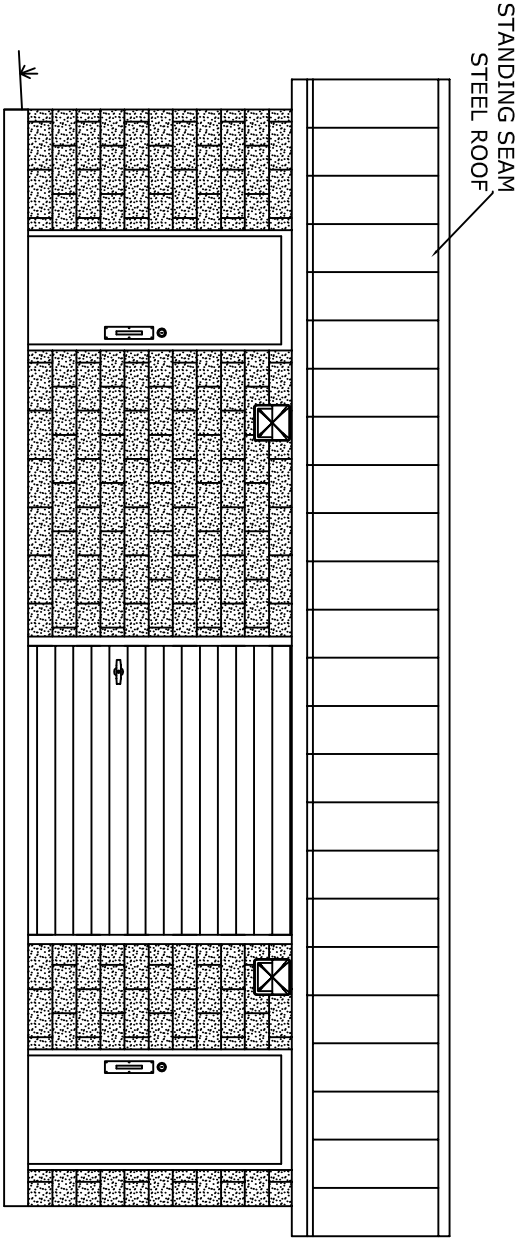
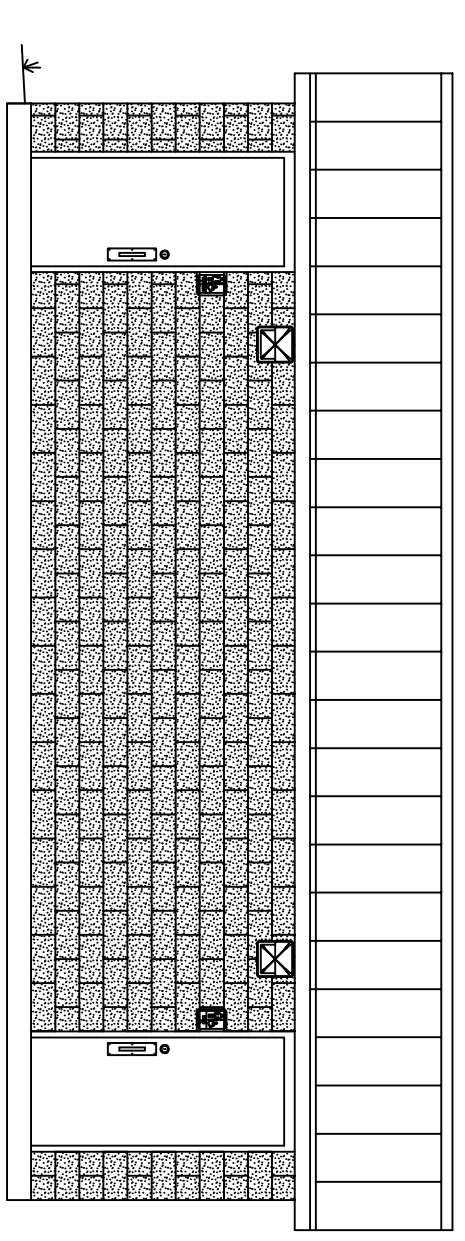
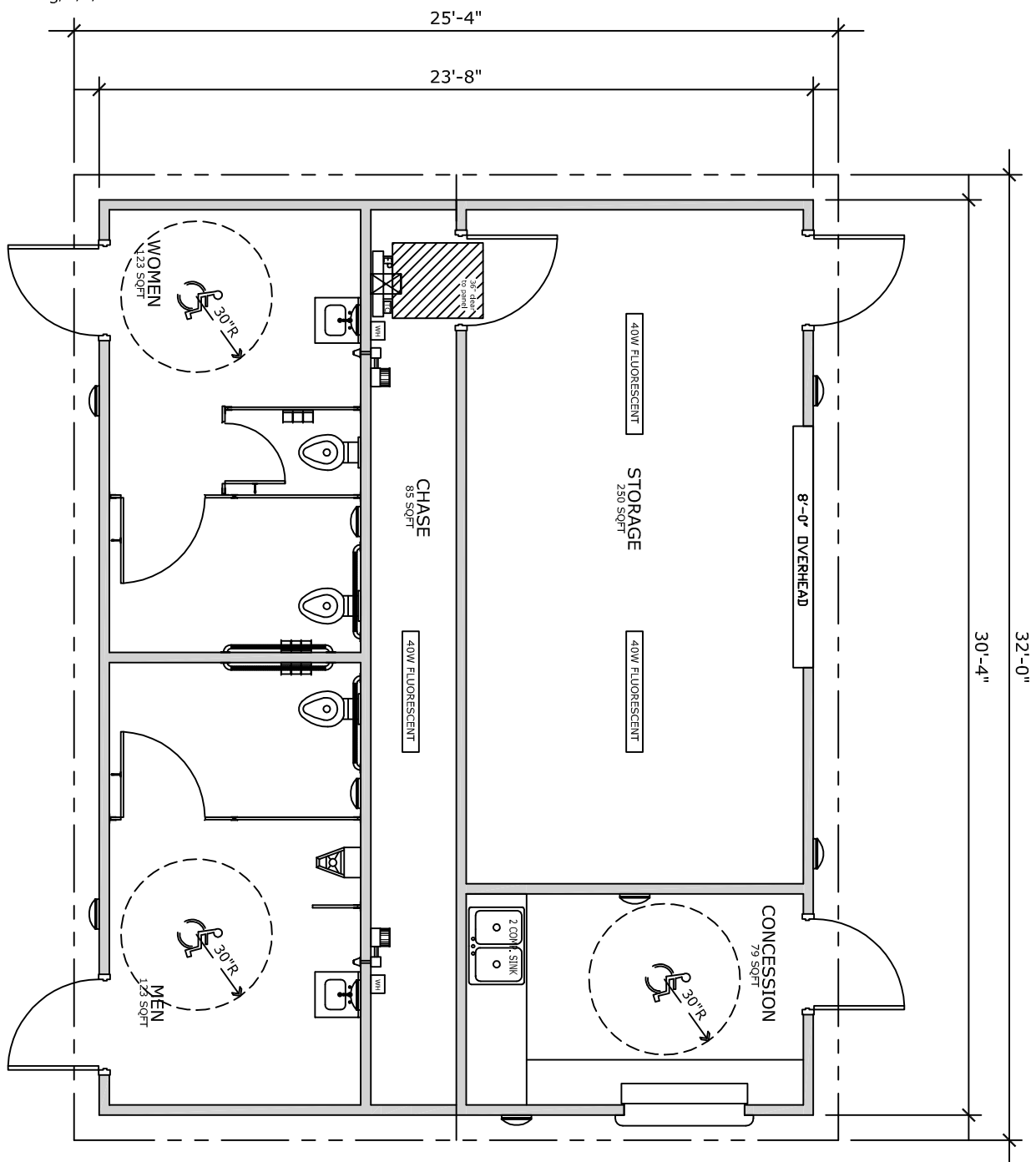

Restroom
Facilities
Limited

1709 GOLT GIRCLE
MARBLE FALLS, TX 78654
512.222.5454

This material is the exclusive property of RESTROOM FACILITIES (the company) and shall not be reproduced or disclosed to others without the written permission of the COMPANY or as authorized by written contract with the COMPANY.
Copyright 2014

RFL MODEL #: B312CNST
PROJECT:
**AUSTIN ISD
PLAYFIELD**

DRAWN BY:	DLS
DATE:	02/03/14
REVISION:	
DATE:	
REVISION:	
DATE:	
REVISION:	

SHEET DESCRIPTION:
PRELIMINARY

SHEET
PR













poligon[®]
PORTER

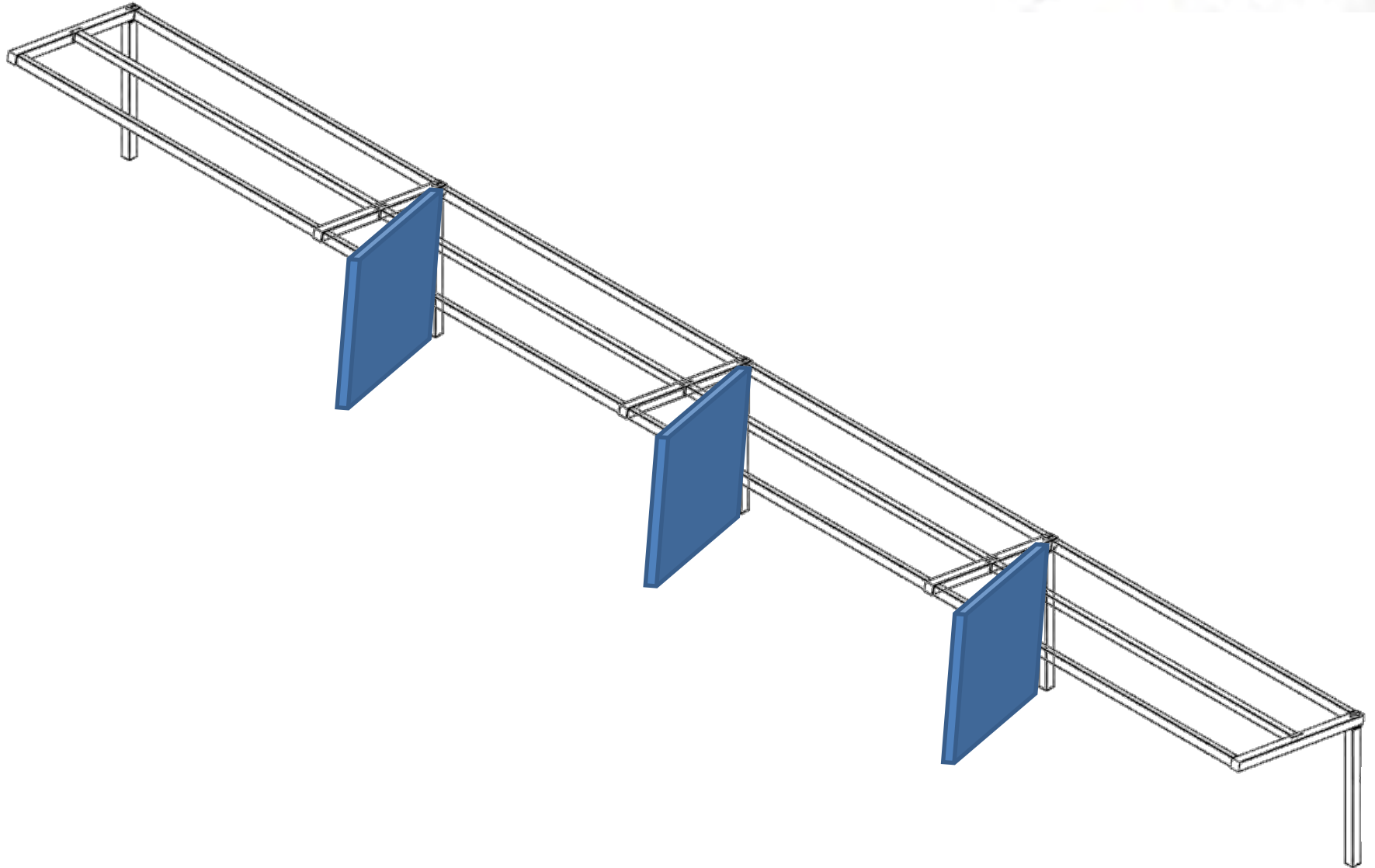

Flat Top







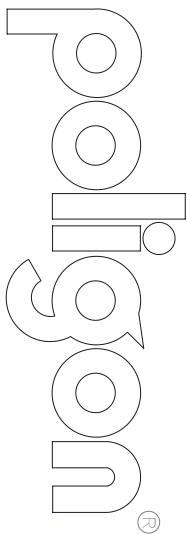

A Division of PORTERCORP 4240 N. 136th AVE. HOLLAND, MI 49424 (616) 399-1963
 and may not be used in the construction or design of a building that is not supplied by Poligon.
 Copyright laws protect the style and visual appearance of the structure while patents may protect other parts of the design.
 PATENTED AND/OR PATENTS PENDING COPYRIGHT 2013 PORTERCORP HOLLAND, MI 49424

PROJECT: CORY'S SPLASH PAD
LOCATION: INDIANAPOLIS, IN
BUILDING TYPE: ARC 10 X 18
ROOF TYPE: MULT-TRIB
FEATURES: DOORS ON ALL SIDES
JOB NUMBER: 50560

DRAWING LIST:

SHEET NUMBER	DRAWING DESCRIPTION
CS	COVER SHEET
1	ARCHITECTURAL ELEVATIONS
2	STRUCTURAL FRAMING PLAN
3	COLUMN LAYOUT
4	BASE PLATE STYLES
5	ELECTRICAL ACCESS AND CUTOUTS

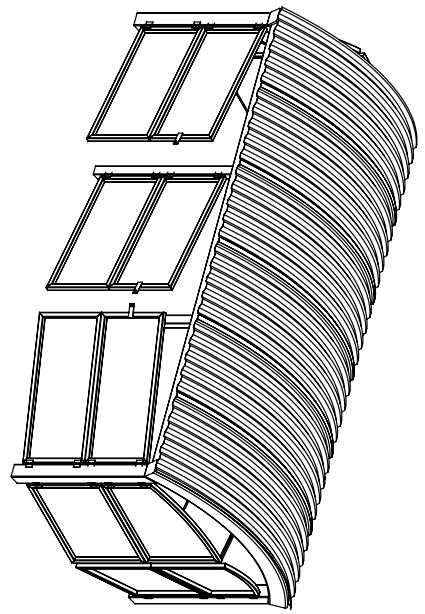

FABRICATOR APPROVALS:
 CITY OF PHOENIX, AZ APPROVED FABRICATOR #C09-2010
 CITY OF LOS ANGELES, CA APPROVED FABRICATOR #1596
 CITY OF RIVERSIDE, CA APPROVED FABRICATOR #SP706-0033
 CITY OF HOUSTON, TX APPROVED FABRICATOR #470
 STARK COUNTY, IN APPROVED FABRICATOR OR #244
 STATE OF UTAH APPROVED FABRICATOR 0290814

CERTIFICATE:
 MIAMI-DADE COUNTY CERTIFICATE OF COMPETENCY NO. 12-0906 07
 PO (POWDER COATING INSTITUTE) 4000 CERTIFIED

MATERIALS:

DESCRIPTION	ASTM DESIGNATION
TUBE STEEL	A500 (GRADE B)
SCHEDULE PIPE	A53 (GRADE B)
PIPE	A1003 (GRADE 50)
LIGHT GAUGE COIL-D FORMED STRUCTURAL STEEL PLATE	A36
ROOF PANELS (STEEL)	A653

GENERAL NOTES:
 UNLESS NOTED OTHERWISE, THIS STRUCTURE WAS DESIGNED TO ONLY SUPPORT WHAT IS SHOWN ON THESE DRAWINGS. POLIGON MUST BE CONTACTED IF ANYTHING ELSE IS TO BE ATTACHED TO THIS STRUCTURE (WALLS, COLUMN WRAPS, RAILINGS, ETC.) SO THE DESIGN OF THIS STRUCTURE CAN BE REVIEWED AND POSSIBLY REVISED.
 UNLESS NOTED OTHERWISE, THIS STRUCTURE WAS DESIGNED ASSUMING A 20' SEPARATION BETWEEN ANY ADJACENT STRUCTURE WITH AN EAVE HEIGHT EQUAL TO OR GREATER THAN THE EAVE HEIGHT OF THIS STRUCTURE. IF 20' SEPARATION DOES NOT EXIST, THE DESIGN OF THIS STRUCTURE CAN BE REVIEWED AND POSSIBLY REVISED.
 STRUCTURAL STEEL SHALL BE DETAIL ED, FABRICATED, AND ERRECTED IN ACCORDANCE WITH THE LATEST EDITION OF THE AMERICAN INSTITUTE OF STEEL CONSTRUCTION (AISC) SPECIFICATION MANUAL.

ALL WELDING IS PERFORMED BY AMERICAN WELDING SOCIETY CERTIFIED WELDERS AND CONFORMS TO THE LATEST EDITION OF AWS D1.1 OR D1.3 AS REQUIRED.
 PARTS SHOWN MAY BE UPGRADED DUE TO STANDARDIZED POSSIBLE SUBSTITUTIONS.
 REFER TO THE SHIPPING BILL OF MATERIALS FOR PROPER FIELD INSTALLATION OF THE BUILDING IT IS RECOMMENDED THAT THE PRIMARY FRAME INSTALLER AND THE FIELD INSTALLER BE TRAINED AND EXPERIENCED DOCUMENTED EXPERIENCE INSTALLING THIS TYPE OF PRODUCT.
 FOR PROPER FIELD INSTALLATION OF THE BUILDING IT IS RECOMMENDED THAT ELECTRIC WIRING, IF REQUIRED, BE RUN THROUGH THE STRUCTURAL MEMBERS BEFORE THE BUILDING IS ERRECTED.

STOP!!
 NOT FOR CONSTRUCTION
 USE FOR PRELIMINARY
 PLANNING AND ESTIMATING
 ONLY

CUSTOMER APPROVAL
 MANUFACTURING CANNOT START UNTIL PORTERCORP RECEIVES A SIGNED AND APPROVED COPY.
 APPROVED AS SUBMITTED
 APPROVED AS NOTED
 REVISE AND RESUBMIT AS NOTED
 SIGNATURE: _____
 PRINT NAME: _____
 DATE: _____

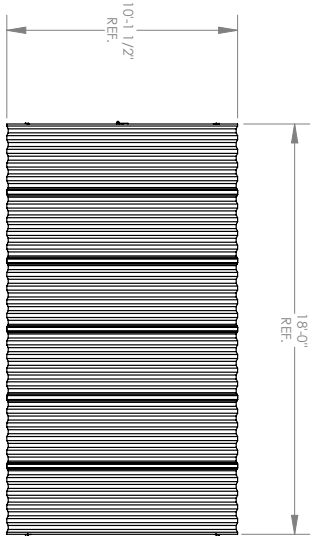

TOP VIEW

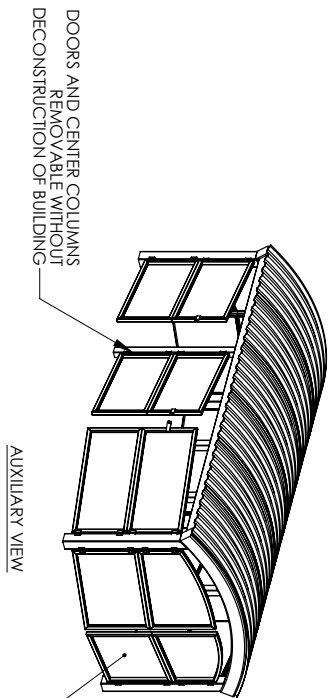

AUXILIARY VIEW

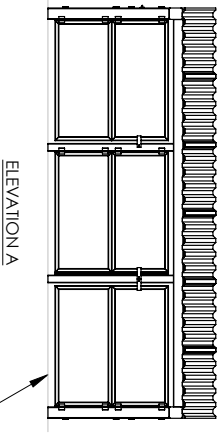

ELEVATION A

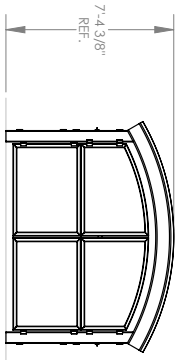

ELEVATION B

FINISH GRADE MOUNTING VARIES BASED ON ENGINEERING REQUIREMENTS VISIT POLYGON.COM FOR OPTIONS.

- GENERAL ROOF NOTES:**
1. METAL ROOFING:
 - 24 GAUGE GALVALUME COATED
 - KYNAR 500 PAINTED TRIM COLOR MATCHES ROOF
 2. SEE POLYGON.COM FOR COLOR OPTIONS

STOP!!
NOT FOR CONSTRUCTION
USE FOR PRELIMINARY PLANNING AND ESTIMATING ONLY

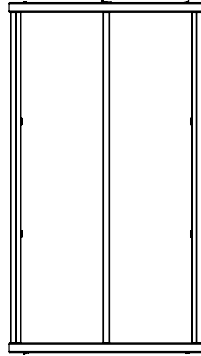

TOP VIEW

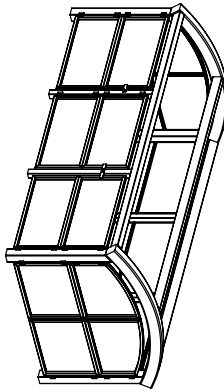

AUXILIARY VIEW

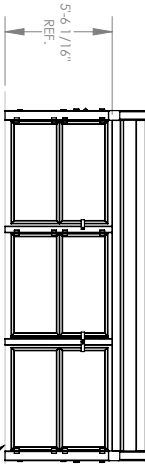

ELEVATION A

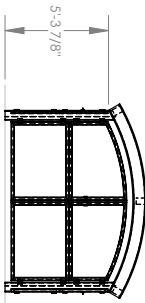

ELEVATION B

FINISH GRADE MOUNTING VARIES BASED ON ENGINEERING REQUIREMENTS VISIT POLYGON.COM FOR OPTIONS.

GENERAL FRAME NOTES:

1. ALL STEEL COMPONENTS, INCLUDING STRUCTURAL MEMBERS, ORNAMENTATION, RAILING, ETC. ARE POWDER COAT FINISHED.
2. FRAME FINISH:
 - MEMBERS SHOT BLASTED TO NEAR WHITE CONDITION (SSPC SP-10)
 - MEMBERS WASHED AND SEALED IN A PHOSPHATE SPRAY
 - MEMBERS PRIME COATED WITH POLI-5000 HIGH PERFORMANCE POWDER APPLIED
 - MEMBERS TOP COATED WITH SUPER DURABLE MERO-ESTER POWDER AND (5YR CURED OPTIONAL EPOXY UNDERCOAT (ECOAT) FULL IMMERSION ELECTRO DEPOSITION PROCESS.
3. SEE POLYGON.COM FOR COLOR OPTIONS.

STOP!!
NOT FOR CONSTRUCTION
USE FOR PRELIMINARY
PLANNING AND ESTIMATING
ONLY

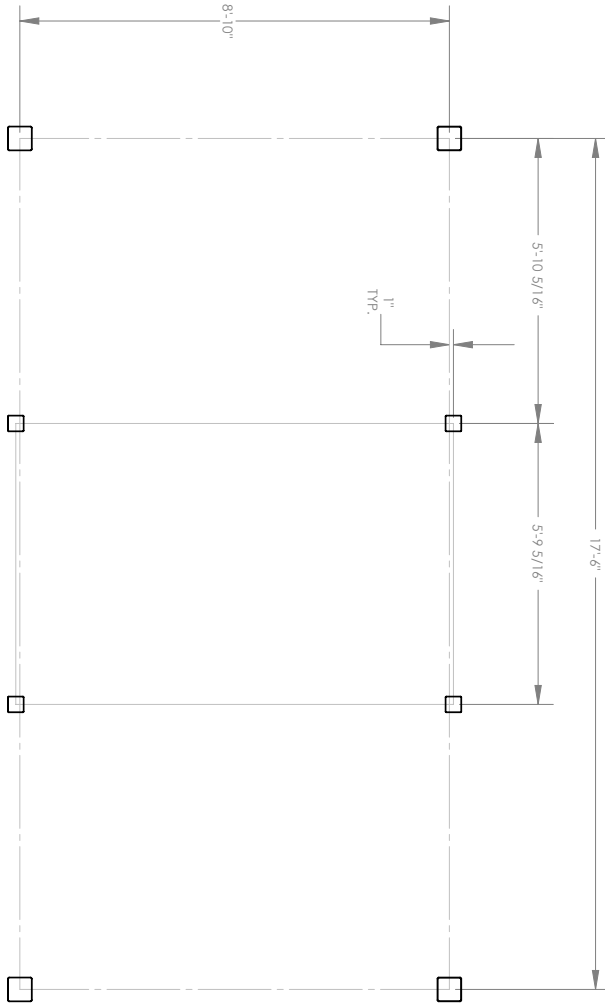

STOP!!
 NOT FOR CONSTRUCTION
 USE FOR PRELIMINARY
 PLANNING AND ESTIMATING
 ONLY

3

PROJECT:
 CORY'S SPLASH PAD
 PROJECT LOCATION:
 INDIANAPOLIS, IN
 DRAWING:
 COLUMN LAYOUT

PRINT DATE:
 6/5/2013
 JOB NO:
 50560

DRAWN BY:
 rallun

REV LEVEL:
 A
 SCALE:
 1:30

CAD MODEL:
 E1~ARC-10x18-MG-50560

poligon®

(616)399-1963
 www.poligon.com

COPYRIGHT 2013
 PATENTED OR PATENTS PENDING
 PORTERCORP 4240 N. 136th AVE HOLLAND, MI 49424
 by **PORTERCORP**

BASEPLATE DESIGN INFORMATION SHEET

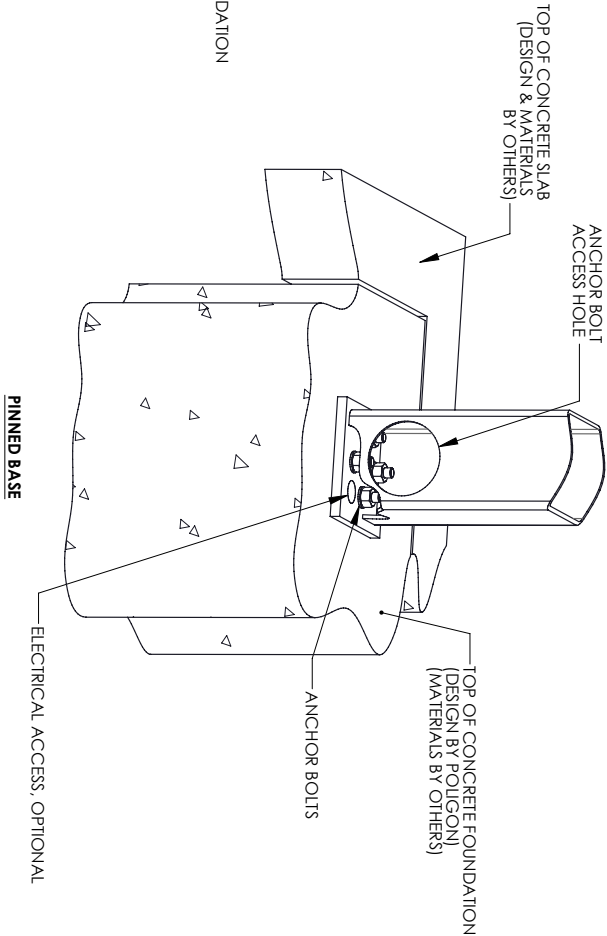
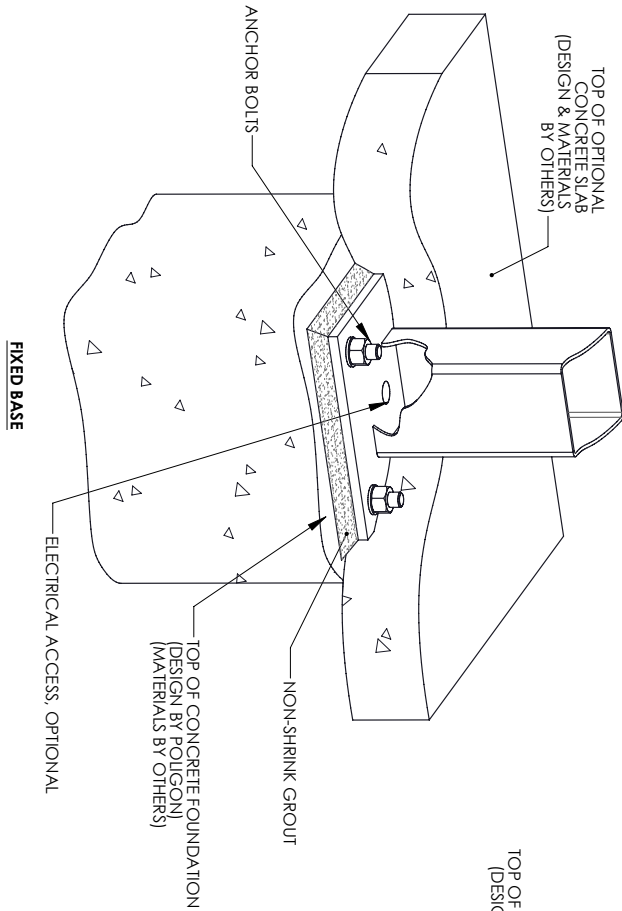

- NOTES:**
1. THE REQUIRED BASE PLATE STYLE IS A FUNCTION OF THE PROJECT SPECIFIC ENGINEERING REQUIREMENTS.
 2. POLYGON ENGINEERING WILL DETERMINE THE REQUIRED BASE PLATE STYLE BECAUSE IT CAN DRAMATICALLY AFFECT THE STRUCTURES DESIGN AND PERFORMANCE.
 3. WE UNDERSTAND THE BASE PLATE STYLE CAN IMPACT THE CONSTRUCTION SEQUENCE (I.E. THE TIMING OF THE SLAB INSTALLATION), SO PLEASE USE THE FOLLOWING INFORMATION AS A GENERAL GUIDE:
 - PINNED BASE PLATES ARE PROVIDED ON THE VAST MAJORITY OF POLYGON STRUCTURES.
 - FIXED BASE PLATES ARE TYPICALLY ONLY REQUIRED ON CANTILEVERED STRUCTURES, ON SOME LARGE STRUCTURES (> 2000 SQ FT), AND IN HIGH SEISMIC REGIONS.
 4. IF YOUR PROJECT HAS UNIQUE BASE PLATE, SLAB, OR FOUNDATION REQUIREMENTS, PLEASE COMMUNICATE THAT INFORMATION WITH POLYGON WHEN PLACING AN ENGINEERING ORDER.

STOP!!
NOT FOR CONSTRUCTION
USE FOR PRELIMINARY
PLANNING AND ESTIMATING

ELECTRICAL ACCESS AND CUTOUTS

WHAT IS ELECTRICAL ACCESS?

- 1-1/8" Ø HOLES PROVIDED THROUGH COLUMN BASEPLATE.
- 3/4" Ø HOLES ARE PROVIDED THROUGH CONNECTION PLATES TO ALLOW WIRE ACCESS UP INTO COMPRESSION TUBE/RING OR RIDGE BEAM.
- ELECTRICAL ACCESS INTO ADDITIONAL MEMBERS IS AVAILABLE UPON REQUEST.

WHAT ARE ELECTRICAL CUTOUTS?

- ROUND HOLE OR RECTANGULAR CUTOUTS IN MEMBERS, REQUIRED FOR INSTALLATION OF ELECTRICAL FIXTURES OR WIRE ACCESS.
- ALL CUTOUT REQUESTS MUST BE REVIEWED BY OUR ENGINEERING DEPARTMENT (THEIR PLACEMENT MAY AFFECT STRUCTURAL INTEGRITY).
- POLYGON IS NOT RESPONSIBLE FOR UNAUTHORIZED CUTOUTS MADE IN THE FIELD.
- UNAUTHORIZED ELECTRICAL CUTOUTS MADE IN THE FIELD WILL VOID THE SHELTER'S WARRANTY.
- TO ENSURE FLUSH MOUNTING OF AN ELECTRICAL FIXTURE, ROUND COLUMNS WILL BE EQUIPPED WITH A WELDED IN ENCLOSURE THAT ACCOMMODATES A STANDARD UL LISTED BOX.

HOW TO COMMUNICATE CUTOUT REQUIREMENTS

- WHEN ORDERING THE STRUCTURE, MARK UP THE SUBMITTAL DRAWINGS TO ACCURATELY COMMUNICATE CUTOUTS WITH EXACT DIMENSIONS(S) AND LOCATION(S).
- IF THE SUBMITTAL SET IS NOT AVAILABLE, MARK UP THE SKETCHES ON THIS SHEET SHOWING CUTOUTS WITH EXACT DIMENSIONS(S) AND LOCATIONS(S).
- CUTOUT SIZE MUST BE COMMUNICATED AT TIME OF ORDER.
- INDICATE ON WHICH SIDE OF MEMBER THE CUTOUT IS TO BE LOCATED.
- IF NOT SPECIFIED TO THE BOTTOM, CENTER, OR TOP OF CUTOUT, DIMENSION WILL BE TAKEN TO THE BOTTOM OF THE CUTOUT.

WHERE CAN CUTOUTS BE LOCATED?

- OUTLET CUTOUTS ARE TYPICALLY LOCATED 18" ABOVE GRADE ON THE INSIDE FACE OF THE COLUMN.
- LIGHT SWITCH CUTOUTS ARE TYPICALLY LOCATED 48" ABOVE GRADE ON THE INSIDE FACE OF THE COLUMN.
- ALL CUTOUTS ARE TYPICALLY AT LEAST 12" FROM ANY STRUCTURAL JOINTS.
- ALL CUTOUTS ARE TYPICALLY CENTERED ON THE MEMBER WALL (NOT CLOSE TO THE CORNERS).
- CONTACT LOCAL POLYGON REPRESENTATIVE WITH ANY ADDITIONAL QUESTIONS. CUTOUTS CAN BE LOCATED THROUGH COVER PLATES.

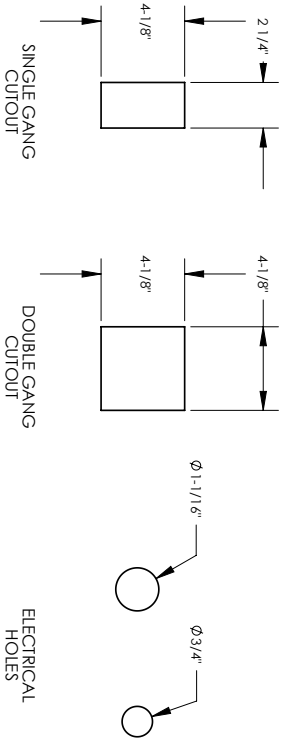

TYPICAL ELECTRICAL CUTOUTS

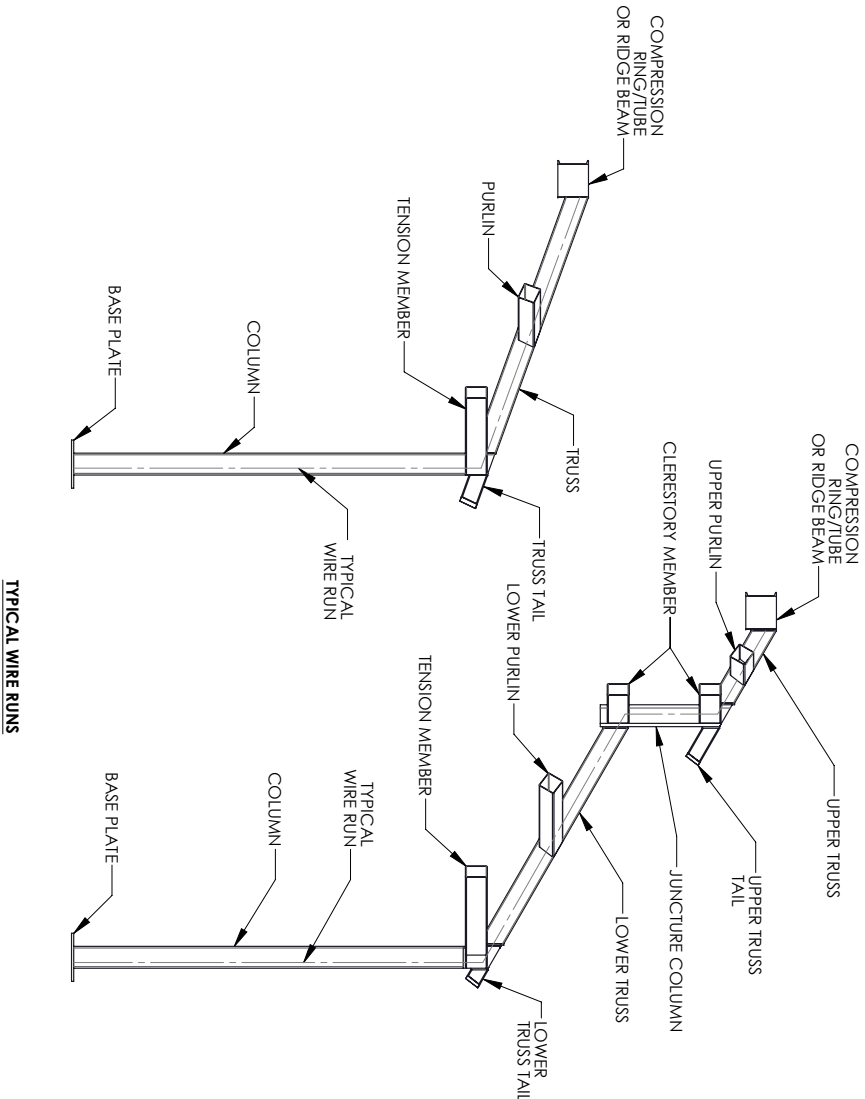

TYPICAL WIRE RUNS



What is a Cooperative Purchasing Organization?

A cooperative Purchasing Organization is a cost savings vehicle available to public entities. Contracts are publicly solicited by a lead public agency in accordance with government purchasing regulations. NPPGov is not a reseller, but rather a purchasing vehicle that offers publicly solicited agreements to local and state Government agencies throughout the nation. NPPGov members are eligible to purchase through our contracts saving time and money.

How does NPPGov work?

NPPGov uses a lead public agency to publicly solicit and award contracts through a Request for Proposal process. Once you are registered with NPPGov, you can purchase directly through the vendor while utilizing the savings our contracts provide. Using our contracts is simple and fast. NPPGov is your procurement solution provider.

How does a public entity participate?

Register to become a NPPGov member:

1. Visit our Website: www.nppgovernment.com.
2. Click "Join Now"
3. Select your industry from the "Market Segment" dropdown menu.
4. If applicable, select the appropriate association from the "Association: dropdown menu.
5. Complete the registration form and submit.
6. You will receive a welcome call and e-mail confirming your membership within 24 hours. The welcome e-mail will include your username and password. Vendor discount information can be accessed using your login credentials to log into www.nppgovernment.com.

What are the NPP membership costs and obligations?

There are no costs or user fees, no obligation to purchase, and no minimum purchasing requirement.

Who is eligible?

State, city, county, district, municipal or local tax-supported government agencies, including but not limited to: turnpikes, K-12 public schools, townships, park and recreation, metro/city transits, public works, and public higher education facilities, such as colleges and universities.



Vortex Midwest Splashpad Installations



Thorn Park Splashpad

Brownstown, MI

Vern Gustafsson

734-675-5913

vgustafsson@brownstown-mi.org



Blue Heron Bay

Washtenaw County, MI

Jeff Dehring

734-971-6337

dehringi@ewashtenaw.org



The Centre Splashpad

Adrian, MI

Ryan Johnson

517-438-8837

rjohnson@lenawee.org



Splash Playground

Canton, MI

Brad Sharp

734-394-5363

brad.sharp@canton-mi.org

CONTACT US

Cory Anderson

GM/Owner

Project Coordination

1-877-586-7839 ext: 362

Cell: 517-488-9469

cory@vortex-midwest.com

Williamston, MI

Angie Monroe

Office Manager

1-877-586-7839 ext: 361

Cell: 517-375-2316

angie@vortex-midwest.com

Williamston, MI

Jeff Myszak

Installation Specialist

Cell: 517-202-4157

jeff@vortex-midwest.com

Williamston, MI

Darrell Klein

Installation Specialist

Cell: 989-277-5908

Darrell@vortex-midwest.com

Williamston, MI

Vortex Midwest Office

425, West Grand River- Suite B

Williamstown, MI 48895

1-877-586-7839



Zimbra**lgarrett@ytown.org**

Work Session Agenda Item - 2016 Preliminary Budget

From : Tammie Keen
<tkeen@ytown.org>

Tue, Oct 13, 2015 10:27 AM

Subject : Work Session Agenda Item
- 2016 Preliminary Budget

To : Lisa Garrett
<lgarrett@ytown.org>

Cc : Karen Lovejoy Roe
<klovejoyroe@ytown.org>,
Brenda Stumbo
<bstumbo@ytown.org>,
Javonna Neel
<jneel@ytown.org>

Hi Lisa:

We would like to place the following on the Work Session agenda:

1. Discussion of 2016 Preliminary Budget:
 - A. 101 - General Fund
 - B. 206 - Fire
 - C. 208 - Parks
 - D. 212 - BSR II
 - E. 226 - Environmental Services
 - F. 230 - Recreation

Thanks :)
Tammie

Zimbra**lgarrett@ytown.org**

Re: sign

From : Brenda Stumbo
<bstumbo@ytown.org>

Wed, Oct 07, 2015 02:17 PM

Subject : Re: sign**To :** Scott Martin
<SMartin@ScioTownship.org>**Cc :** Karen Lovejoy Roe
<klovejoyroe@ytown.org>,
Larry Doe
<lroe@ytown.org>,
MIPANTHERS@aol.com
<mipanthers@aol.com>, Mike
Martin
<satur9@comcast.net>, Lisa
Garrett
<lgarrett@ytown.org>,
Brenda Stumbo
<bstumbo@ytown.org>,
Tammie Keen
<tkeen@ytown.org>

Scott, this is awesome.

When we named the Golf Course Pro Shop after Leon Jackson, it was brought to the board to vote in support of naming the building and then we had a dedication ceremony in honor of the naming. I will carbon copy this to the board members and township attorney and the clerk's office can assist with placing this on the agenda, the timing is perfect since we are updating our signs. Brenda

----- Original Message -----

From: "Scott Martin" <SMartin@ScioTownship.org>
To: "Brenda Stumbo" <bstumbo@ytown.org>
Sent: Wednesday, October 7, 2015 1:37:34 PM
Subject: sign

Dear Brenda,

At last night's Board meeting we decided to look at replacing the panels in our current sign in front for the civic center and our court office.

I am asking if the Ypsilanti Township Board would entertain naming our Civic Center and Court office after two people who has dedicated their life for the betterment of our township.

I am proposing the Civic Center being named after T.R. Stumbo, a man who ran our Township for many years and even after leaving office of the Township he still dedicated himself to helping not only the Township officials but all people of Ypsilanti Township.

I am proposing that we name the Ypsilanti Township Court office after John Collins. Judge Collins was a long time judge in our community who work for many years supporting the Township and dedicated his life to running our court system as one of the best in the State of Michigan.

Please let me know what we have to do to get this to the rest of the Township Board members and see if this can be supported by us all.

Thank you,
Scott Martin
Scio Township Utilities Director
(734) 369-9350

--

Brenda L. Stumbo
Ypsilanti Township Supervisor
(734) 481-0617

REVIEW AGENDA

- A. SUPERVISOR STUMBO WILL REVIEW BOARD MEETING AGENDA

OTHER DISCUSSION

- A. BOARD MEMBERS HAVE THE OPPORTUNITY TO DISCUSS ANY OTHER PERTINENT ISSUES



Charter Township of Ypsilanti

7200 S. HURON RIVER DRIVE • YPSILANTI, MI 48197

SUPERVISOR BRENDA STUMBO • CLERK KAREN LOVEJOY ROE • TREASURER LARRY DOE
TRUSTEES: JEAN HALL CURRIE • STAN ELDRIDGE • MIKE MARTIN • SCOTT MARTIN

REGULAR MEETING AGENDA

TUESDAY, OCTOBER 20, 2015

7:00 P.M.

1. CALL TO ORDER
2. PLEDGE OF ALLEGIANCE AND INVOCATION
3. PUBLIC COMMENTS
4. CONSENT AGENDA
 - A. MINUTES OF THE OCTOBER 6, 2015 WORK SESSION AND REGULAR MEETING
 - B. STATEMENTS AND CHECKS
 1. STATEMENTS AND CHECKS FOR OCTOBER 20, 2015 IN THE AMOUNT OF \$1,072,041.39
 2. CHOICE HEALTH CARE DEDUCTIBLE ACH EFT FOR SEPTEMBER IN THE AMOUNT OF \$31,422.88
 3. CHOICE HEALTH CARE ADMIN FEE FOR AUGUST IN THE AMOUNT OF \$1,177.50
 - C. SEPTEMBER 2015 TREASURER'S REPORT
5. SUPERVISOR REPORT
6. CLERK REPORT
7. TREASURER REPORT
8. TRUSTEE REPORT
9. ATTORNEY REPORT
- A. GENERAL LEGAL UPDATE

OLD BUSINESS

1. 2nd READING OF RESOLUTION 2015-41, PROPOSED ORDINANCE 2015-453, AN ORDINANCE AMENDING THE CODE OF ORDINANCES CHAPTER 30, ARTICLE II, ENTITLED FIRE PREVENTION CODE BY ADOPTION OF THE 2012 EDITION OF THE INTERNATIONAL FIRE PREVENTION CODE
(1st READING HELD AT THE OCTOBER 6, 2015 REGULAR MEETING)

2. 2nd READING OF RESOLUTION 2015-42, PROPOSED ORDINANCE 2015-454, AN ORDINANCE AMENDING ORDINANCE NO. 74, TOWNSHIP ZONING ORDINANCE, TO REZONE 2590 EAST MICHIGAN AVENUE, PARCEL K-11-01-300-004, FROM ITS CURRENT MHP (MOBILE HOME PARK) ZONING CLASSIFICATION TO B-3 (GENERAL BUSINESS) ZONING CLASSIFICATION
(1ST READING HELD AT THE OCTOBER 6, 2015 REGULAR MEETING)
3. 2nd READING OF RESOLUTION 2015-43, PROPOSED ORDINANCE 2015-455, AN ORDINANCE AMENDING ORDINANCE NO. 74, TOWNSHIP ZONING ORDINANCE, TO REZONE 953 EAST MICHIGAN AVENUE, PARCEL K-11-10-205-039, FROM ITS CURRENT MHP (MOBILE HOME PARK) ZONING CLASSIFICATION TO B-3 (GENERAL BUSINESS) ZONING CLASSIFICATION
(1ST READING HELD AT THE OCTOBER 6, 2015 REGULAR MEETING)

NEW BUSINESS

1. BUDGET AMENDMENT #13
2. REQUEST FOR APPROVAL OF CONCEPTUAL SPLASH PAD DESIGN AS PRESENTED TO THE PARK COMMISSION AND TOWNSHIP BOARD FROM VORTEX TO BE LOCATED AT FORD LAKE PARK AND THE ESTABLISHMENT OF A JOINT PARK COMMISSION/BOARD OF TRUSTEES COMMITTEE TO RESEARCH FINANCES, GRANTS AND DEVELOP A PLAN TO MOVE THE SPLASH PAD PROJECT FORWARD WITH A RECOMMENDATION TO THE TOWNSHIP BOARD WITH SUPPORT OF THE PARK COMMISSION
3. REQUEST TO APPROVE NEW POLICY ON SALE OF TOWNSHIP OWNED PROPERTY
4. REQUEST AUTHORIZATION FOR SALE OF TWO TOWNSHIP OWNED PARCELS, K-11-11-202-004 AND K-11-11-202-040 TO ERICK AND CLAIRA ELLICOTT AND AUTHORIZATION TO SIGN THE LETTER OF AGREEMENT
5. RESOLUTION 2015-44, DECLARING OCTOBER 24 AS ROSIE THE RIVETER DAY
6. REQUEST OF MIKE RADZIK, OCS DIRECTOR FOR AUTHORIZATION TO SEEK LEGAL ACTION IF NECESSARY TO ABATE PUBLIC NUISANCE FOR PROPERTIES LOCATED AT 881 ALLEN, 535 GLENWOOD, 1847 WATSON AND 582 ONANDAGA IN THE AMOUNT OF \$20,000.00 BUDGETED IN LINE ITEM #101-950-000-801-023

OTHER BUSINESS

AUTHORIZATION AND BIDS

1. REQUEST OF JEFF ALLEN, RESIDENTIAL SERVICES DIRECTOR TO SEEK SEALED BIDS FOR PRINTING OF THE "HELPFUL HANDBOOK"
2. REQUEST OF ERIC COPELAND, FIRE CHIEF TO AMEND THE COST OF THE FIRE STATION HEADQUARTERS ROOF REPLACEMENT BY AN INCREASE OF \$3,500.00 FOR A TOTAL AMOUNT OF \$53,450.00 BUDGETED IN LINE ITEM #206-970-000-971-008

3. REQUEST OF JUSTIN BLAIR, DIRECTOR OF GOLF TO WAIVE FINANCIAL POLICY AND AWARD LOW BID FOR RENOVATION OF GREENS #3 AND MAINTENANCE WORK OF GREENS #2 AND #5 TO EAGLE GOLF CONSTRUCTION IN THE AMOUNT OF \$19,087.50 BUDGETED IN LINE ITEM #584-584-000-971-000

PUBLIC COMMENTS

CONSENT AGENDA

CHARTER TOWNSHIP OF YPSILANTI
MINUTES OF THE OCTOBER 6, 2015 WORK SESSION

Supervisor Stumbo called the meeting to order at approximately 5:00 p.m. in the Ypsilanti Township Civic Center Board Room, 7200 S. Huron River Drive, Ypsilanti Township.

Members Present: Supervisor Brenda L. Stumbo, Clerk Karen Lovejoy Roe, Treasurer Larry Doe and Trustees: Stan Eldridge, Scott Martin and Trustee Mike Martin (arrived at 5:21p.m.)

Members Absent: Trustee Jean Hall Currie

Legal Counsel: Wm. Douglas Winters

CIVIC CENTER SIGNAGE

Jeff Allen, Residential Services Director, stated the township signs at Veterans Drive and at the entrance to the Civic Center need to be replaced. Mr. Allen discussed possibly getting a lighted sign similar to the sign at the LEC Building. He said Huron Signs gave an estimate of \$35,000 for a wireless electronic sign that is 36 sq. feet. He reported the cost to update the current sign, including new panels; with the changes that are needed would be \$11,094. Mr. Allen asked the Board for direction in what type of sign is preferred. Treasurer Doe asked if the current sign could be lighted and Mr. Allen said it could. Mr. Allen said he did have contractors take out the bushes and lay a couple empty conduits for future electrical. He also stated that in the \$11,094 quote they will be adding other signage that is needed. Supervisor Stumbo stated that with the electronic sign we could inform the community when needed but we could also utilize the sign at the LEC. The Board concluded to replace the current sign with similar signage. Mr. Allen will get additional bids for updating the current sign and bring the bids back to the Board.

Ms. Kaiser, Township Resident, stated that electronic signs are distracting to drivers and would prefer the township save the extra money and purchase a lighted sign.

CHARTER TOWNSHIP OF YPSILANTI
OCTOBER 6, 2015 WORK SESSION MINUTES
PAGE 2

Mr. Allen asked the Board if we could waive getting sealed bids. He would call other sign companies and get their quotes. Supervisor Stumbo stated that it would be added to the agenda under Other Business.

2016 FISCAL YEAR BUDGET REVIEW

Supervisor Stumbo stated that the Health Care Rate increase is 4.5% instead of the 20% that was anticipated. She also stated that there was not an increase in the renewal for Dental Insurance. Supervisor Stumbo stated that she needed direction on the salary increases. She reported the Union negotiated a 1.5% increase and she would like to add 1.5% increase for Non-Union members. She said the Judge is asking for a market adjustment of 16% for Magistrate Mark Nelson. Supervisor Stumbo stated that she would not recommend doing a Market Adjustment of that size. Trustee Scott Martin asked if the 1.5% was for Township Officials. Supervisor Stumbo stated that it was included for non-union employees. Trustee Scott Martin stated that he would agree to research market adjustments and believes we should do the same kind of adjustment for our own employees. Clerk Lovejoy Roe stated that there is a possibility that we could have less revenue next year. Clerk Lovejoy Roe agrees that Magistrate Mark Nelson is doing two jobs but he was hired in to do both of those jobs. She stated we have lost 1/3 of our taxable revenue. Clerk Lovejoy Roe also stated that there are other people employed at the Township who are probably under market rates. Clerk Lovejoy Roe believes that Ypsilanti Township is not in a position to offer a 16% increase for an employee. Treasurer Doe stated that we could look at market rates next year but now isn't the right time. Supervisor Stumbo agreed we do not know what might happen in the future but that we could get numbers together for next year. The Board agreed to a 1.5% increase for Magistrate Mark Nelson.

Javonna Neel, Accounting Director, requested direction of the Board regarding the structure for presenting our budgets. Director Neel requested that the budgets be done by classification summaries. She explained they would be by personnel wages, fringe benefits, utilities, etc. and would all be based on classification instead of going line by line. After Javonna Neel showed examples, the Board agreed on this structure change when presenting the budget. Ms. Neel

**CHARTER TOWNSHIP OF YPSILANTI
OCTOBER 6, 2015 WORK SESSION MINUTES**

PAGE 3

said our web site continues with the line item format. Director Neel described how to read the brief summary and overview of the budget. Supervisor Stumbo stated that each fund will be recorded in this structure.

GPS SYSTEM FOR TOWNSHIP VEHICLES

Jeff Allen, Residential Services Director, stated that the GPS systems serviced by Wexsmart sent him a notice stating that the system needs to be upgraded, including adding new hardware in our vehicles. Mr. Allen reported he was contacted by our Verizon Representative about moving our GPS system to Verizon. He said that currently we pay \$27.00 to \$56.00 a vehicle; the Verizon Representative quoted \$18.95 per vehicle. Mr. Allen was not sure if that price would include our chipper truck. Mr. Allen stated that we currently have 15 vehicles with GPS at a cost of \$407 per month; with Verizon he said we would have an upgraded system for 29 vehicles at a cost of \$550 per month and a \$3200 charge for equipment. He said our current system will have to be upgraded if we continue with them. Mr. Allen said he would like to cancel our current contract. Supervisor Stumbo stated that with a difference of a little over \$100 a month with double the vehicles it would be a good change. Mr. Allen commented that with the new system it has a better record keeping capability. Mr. Allen will get all the information and bring it back to the board at the next meeting including cost for adding Township Fire Trucks.

AGENDA REVIEW:

CONSENT AGENDA

A. MINUTES OF THE SEPTEMBER 15, 2015 WORK SESSION AND REGULAR MEETING

B. STATEMENTS AND CHECKS

1. STATEMENTS AND CHECKS FOR OCTOBER 6, 2015 IN THE AMOUNT OF \$1,451,298.63.

**CHARTER TOWNSHIP OF YPSILANTI
OCTOBER 6, 2015 WORK SESSION MINUTES
PAGE 4
AUGUST 2015 TREASURER'S REPORT**

ATTORNEY REPORT:

A. GENERAL LEGAL UPDATE

Attorney Winters stated that on Friday, October 2, 2015 he had a second conference call with Representatives of Fannie Mae/Freddie Mac. He reported they are still under a conservatorship from the Federal Finance Housing Authority. Attorney Winters continued to address the problems that are incurred by not releasing these houses immediately after 30 days and instead wait 6 months or longer. He said that by leaving them abandoned, the Township watches the houses deteriorate with water, sewage, and mold problems along with vandalism. Attorney Winters stated that the gentleman they spoke with has promised to call back later this week with additional information. He was hopeful that we may see something soon in helping with the foreclosed homes in Ypsilanti Township and said we can apply this process to other houses foreclosed by other financial institutions.

Attorney Winters stated that we have good people living in our neighborhoods and through neighborhood watch groups they have helped us keep up to date on what is happening in the Township. He stated that he is encouraged with the progress we are making.

NEW BUSINESS

1. BUDGET AMENDMENT #12

Clerk Lovejoy Roe stated that this is an increase in revenue expenditure for additional cameras in the Sugarbrook and Thurston Neighborhood and we have to re-budget revenue that we received on the closings for the homes Habitat for Humanity purchased from us.

**CHARTER TOWNSHIP OF YPSILANTI
OCTOBER 6, 2015 WORK SESSION MINUTES
PAGE 5**

- 2. REQUEST FOR AUTHORIZATION TO PROVIDE \$90,000.00 TO HABITAT FOR HUMANITY FOR THE PURCHASE OF 1358 ANDREA AND 1424 ANDREA IN THE SUGARBROOK NEIGHBORHOOD FOR COMPLETE REHABILITATION AND SALE TO OWNER OCCUPIED FAMILIES BUDGETED IN LINE ITEM #101-950-000-969-010 FOR THE PURPOSE OF NEIGHBORHOOD STABILIZATION AND REVITALIZATION**

Supervisor Stumbo had suggested at a neighborhood watch meeting that by selling homes to Habitat for Humanity they will keep them under home ownership. Supervisor Stumbo stated that by having a Community Organizer working with Habitat who will conduct meetings to find out what is important to the residents and what changes they want to see in their neighborhood. She also said that this has helped stabilize the neighborhoods in Gault Village and West Willow. She reported she is trying to get resources to help with this type of work in Sugarbrook. Clerk Lovejoy Roe stated that with these types of projects they are not only renovating the houses, but also making positive changes in the neighborhood.

- 3. 1ST READING OF RESOLUTION 2015-41, PROPOSED ORDINANCE 2015-453, AN ORDINANCE AMENDING THE CODE OF ORDINANCES CHAPTER 30, ARTICLE II, ENTITLED FIRE PREVENTION CODE BY ADOPTION OF THE 2012 EDITION OF THE INTERNATIONAL FIRE PREVENTION CODE**

Supervisor Stumbo asked what edition we currently have. Eric Copeland, Fire Chief, stated that we currently have the 2009 Edition. He said that the 2012 Edition will keep us up on the current codes.

- 4. 1ST READING OF RESOLUTION 2015-42, PROPOSED ORDINANCE 2015-454, AN ORDINANCE AMENDING ORDINANCE NO. 74, TOWNSHIP ZONING ORDINANCE, TO REZONE 2590 EAST MICHIGAN AVENUE, PARCEL K-11-01-300-004, FROM ITS CURRENT MHP (MOBILE HOME PARK) ZONING CLASSIFICATION TO B-3 (GENERAL BUSINESS) ZONING CLASSIFICATION**

**CHARTER TOWNSHIP OF YPSILANTI
OCTOBER 6, 2015 WORK SESSION MINUTES**

PAGE 6

- 5. 1ST READING OF RESOLUTION 2015-43, PROPOSED ORDINANCE 2015-455, AN ORDINANCE AMENDING ORDINANCE NO. 74, TOWNSHIP ZONING ORDINANCE, TO REZONE 953 EAST MICHIGAN AVENUE, PARCEL K-11-10-205-039, FROM ITS CURRENT MHP (MOBILE HOME PARK) ZONING CLASSIFICATION TO B-3 (GENERAL BUSINESS) ZONING CLASSIFICATION**

Joe Lawson, Planning and Development Coordinator, confirmed that these parcels are owned by the Township. He stated that we previously had hoped someone would purchase these properties but since they haven't it was decided to move forward with these Resolutions.

- 6. REQUEST TO APPROVE ANNUAL SENIOR NUTRITION AGREEMENT WITH WASHTENAW COUNTY, FUNDED THROUGH A FEDERAL GRANT AND TO AUTHORIZE SIGNING OF THE AGREEMENT**

Supervisor Stumbo stated that this is a food program for Seniors in the Township. The amount is \$15,000 which is an increase from previous years.

- 7. REQUEST AUTHORIZATION TO SIGN PURCHASE AGREEMENT WITH DTE FOR INSTALLATION OF ONE (1) OVERHEAD FED BLACK 135 WATT AUTOBAHN LED MOUNTED ON A 17'-6" CODE 48 ARM ON AN EXISTING WOOD POLE TO BE LOCATED AT THE WESTBOUND INTERSECTION OF MICHIGAN AVENUE AND DORSET IN THE AMOUNT OF \$658.28 BUDGETED IN LINE ITEM #101-956-000-926-050**

- 8. REQUEST OF NEXUS GAS TRANSMISSION FOR AUTHORIZATION TO SURVEY TOWNSHIP OWNED PARCELS K-11-23-200-001, K-11-23-400-022 AND K-11-13-330-001**

Supervisor Stumbo stated her concern was that they would be surveying in Ford Lake.

**CHARTER TOWNSHIP OF YPSILANTI
OCTOBER 6, 2015 WORK SESSION MINUTES
PAGE 7**

- 9. SET PUBLIC HEARING DATE OF TUESDAY, NOVEMBER 17, 2015 AT APPROXIMATELY 7:00 PM – CREATION OF LAKEVIEW #2 STREETLIGHT SPECIAL ASSESSMENT DISTRICT**

OTHER BUSINESS

AUTHORIZATION AND BIDS

- 1. REQUEST OF ERIC COPELAND, FIRE CHIEF, TO AWARD LOW BID FOR FIRE STATION HEADQUARTERS ROOF REPLACEMENT TO RAPID ROOFING IN THE AMOUNT OF \$49,950.00 BUDGETED IN LINE ITEM #206-970-000-971-008**

Eric Copeland, Fire Chief, recommended the Board approve the low bid from Rapid Roofing. Attorney Winters stated that he would like to make sure everything is included in the contract according to our contract provision checklist. Alex Mamo stated that Rapid Roofing is moving their business into the Township and that they gave the Township a 10% discount off their original bid.

- 2. REQUEST OF MIKE RADZIK, OCS DIRECTOR, TO AWARD LOW BID FOR ASBESTOS ABATEMENT AND DEMOLITION OF RESIDENTIAL STRUCTURES LOCATED AT 2215 HARMON AND 2572 HEARTHSIDE IN THE AMOUNT OF \$28,075.00 BUDGETED IN LINE ITEM #101-950-000-969-011**

Mike Radzik explained that both of these are open court cases in Circuit Court. The Hearthside address is owned by an estate and they were ordered to do the demolition but they are not financially able to do it. The Township is now authorized to do the demolition. He said the Harmon address had a mortgage but as soon as the Township filed the lawsuit the mortgage company discharged the mortgage. He reported the elderly owner does not have the resources to do the demolition and again the Township is now authorized to do the demolition. Mr. Radzik stated that he continues to get complaints on the Harmon property from residents and from the neighborhood watch group regarding the condition of the property.

**CHARTER TOWNSHIP OF YPSILANTI
OCTOBER 6, 2015 WORK SESSION MINUTES
PAGE 8**

- 3. REQUEST OF ERIC COPELAND, FIRE CHIEF, TO SEEK SEALED BIDS FOR THE REPAIR OF THE STORM DRAINS LOCATED IN THE NORTH PARKING LOT OF FIRE HEADQUARTERS AT 222 S. FORD BLVD.**

- 4. REQUEST OF ERIC COPELAND, FIRE CHIEF, TO SEEK SEALED BIDS FOR INSTALLATION OF FIBERGLASS INSULATION IN THE ATTIC AND SOFFIT AREA OF FIRE HEADQUARTERS AT 222 S. FORD BLVD.**

The meeting adjourned at approximately 6:55 p.m.

Respectfully Submitted,

Karen Lovejoy Roe, Clerk

**CHARTER TOWNSHIP OF YPSILANTI
MINUTES OF THE OCTOBER 6, 2015 REGULAR MEETING**

Supervisor Stumbo, called the meeting to order at approximately 7:00 p.m. in the Ypsilanti Township Civic Center Board Room. 7200 S. Huron River Drive, Ypsilanti Township. The Pledge of Allegiance was recited and a moment of silent prayer observed.

MEMBERS PRESENT: Supervisor Brenda L. Stumbo, Clerk Karen Lovejoy Roe, Treasurer Larry Doe, Trustees Stan Eldridge, Mike Martin, and Scott Martin

MEMBERS ABSENT: Trustee Jean Hall Currie

LEGAL COUNSEL: Attorney Wm. Douglas Winters

PUBLIC COMMENTS

Ms. Kaiser, Township Resident, questioned how much the Road Commission brochure cost. She stated that the money could have been better spent in road repair.

CONSENT AGENDA

A. MINUTES OF THE SEPTEMBER 15, 2015 WORK SESSION AND REGULAR MEETING

1. STATEMENTS AND CHECKS FOR OCTOBER 6, 2015 IN THE AMOUNT OF \$1,451,298.63

B. AUGUST 2015 TREASURER'S REPORT

A motion was made by Clerk Lovejoy Roe, supported by Treasurer Doe to approve the Consent Agenda. The motion carried unanimously.

ATTORNEY REPORT

A. GENERAL LEGAL UPDATE

Supervisor Stumbo stated that Attorney Winters had discussed the General Legal Update at the work session and asked if he had additional comments. Attorney Winters stated that the property on Rossbeck Road and Gill St. was part of a demolition order by the Township and possibly the individuals who purchased these properties from the County may not be aware of that. He stated that a lot of work went in to obtaining these properties and he does not want to go through the process again if something isn't done with these properties.

**CHARTER TOWNSHIP OF YPSILANTI
OCTOBER 6, 2015 REGULAR MEETING MINUTES
PAGE 2**

NEW BUSINESS

1. BUDGET AMENDMENT #12

A motion was made by Clerk Lovejoy Roe, supported by Treasurer Doe to approve Budget Amendment #12 and to Approve Department Line Item Changes as Outlined (see attached).

The motion carried unanimously.

2. REQUEST FOR AUTHORIZATION TO PROVIDE \$90,000.00 TO HABITAT FOR HUMANITY FOR THE PURCHASE OF 1358 ANDREA AND 1424 ANDREA IN THE SUGARBROOK NEIGHBORHOOD FOR COMPLETE REHABILITATION AND SALE TO OWNER OCCUPIED FAMILIES BUDGETED IN LINE ITEM #101-950-000-969-010 FOR THE PURPOSE OF NEIGHBORHOOD STABILIZATION AND REVITALIZATION

A motion by Treasurer Doe, supported by Trustee Eldridge to approve the Request for Authorization to Provide \$90,000.00 to Habitat for Humanity for the Purchase of 1358 Andrea and 1424 Andrea in the Sugarbrook Neighborhood for Complete Rehabilitation and sale to Owner Occupied Families Budgeted in Line Item #101-950-000-969-010 for the Purpose of Neighborhood Stabilization and Revitalization.

Clerk Lovejoy Roe stated it has been a great relationship with the Township and Habitat for Humanity and it will continue with Habitat moving into a different neighborhood in the Township. Mr. Rob Nissly, Habitat for Humanity Housing Director, stated in the next year they will renovate 19 homes in Ypsilanti Township. He said that through the other programs that they offer they have helped 1,000 families in Ypsilanti Township over the last year. Mr. Nissly stated that they have renovated 38 homes in Gault Village and the prices for houses in Gault Village are now out of reach for Habitat to purchase. He is confident that they will have the same progress in the Sugarbrook Neighborhood.

The motion carried unanimously.

3. 1ST READING OF RESOLUTION 2015-41, PROPOSED ORDINANCE 2015-453, AN ORDINANCE AMENDING THE CODE OF ORDINANCES CHAPTER 30, ARTICLE II, ENTITLED FIRE PREVENTION CODE BY ADOPTION OF THE 2012 EDITION OF THE INTERNATIONAL FIRE PREVENTION CODE

A motion was made by Clerk Lovejoy Roe, supported by Treasurer Doe to approve the 1st Reading of Resolution 2015-41, Proposed Ordinance 2015-453 an Ordinance Amending the Code of Ordinances Chapter 30, Article II, Entitled Fire Prevention Code by Adoption of the 2012 Edition of the International Fire Prevention Code (see attached).

**CHARTER TOWNSHIP OF YPSILANTI
OCTOBER 6, 2015 REGULAR MEETING MINUTES
PAGE 3**

The motion carried as follows:

Eldridge:	Yes	S. Martin:	Yes	Stumbo:	Yes
Lovejoy Roe:	Yes	Doe:	Yes	M. Martin:	Yes

- 4. 1ST READING OF RESOLUTION 2015-42, PROPOSED ORDINANCE 2015-454, AN ORDINANCE AMENDING ORDINANCE NO. 74, TOWNSHIP ZONING ORDINANCE, TO REZONE 2590 EAST MICHIGAN AVENUE, PARCEL K-11-01-300-004, FROM ITS CURRENT MHP (MOBILE HOME PARK) ZONING CLASSIFICATION TO B-3 (GENERAL BUSINESS) ZONING CLASSIFICATION**

A motion was made by Clerk Lovejoy Roe, supported by Trustee Eldridge to approve 1st Reading of Resolution 2015-42, Proposed Ordinance 2015-454, an Ordinance Amending Ordinance No. 74, Township Zoning Ordinance, to Rezone 2590 East Michigan Avenue, Parcel K-11-01-300-004, From its Current MHP (Mobile Home Park) Zoning Classification to B-3 (General Business) Zoning Classification (see attached).

Mr. Joseph Lawson, Planning and Development Coordinator, stated that as mentioned in the work session the Township acquired the property by a foreclosure. He said the property has not sold with the current zoning classification and the Township was hoping that by changing the zoning it may create more interest for someone to purchase the property.

The motion carried as follows:

Eldridge:	Yes	S. Martin:	Yes	Stumbo:	Yes
Lovejoy Roe:	Yes	Doe:	Yes	M. Martin:	Yes

- 5. 1ST READING OF RESOLUTION 2015-43, PROPOSED ORDINANCE 2015-455, AN ORDINANCE AMENDING ORDINANCE NO. 74, TOWNSHIP ZONING ORDINANCE, TO REZONE 953 EAST MICHIGAN AVENUE, PARCEL K-11-10-205-039, FROM ITS CURRENT MHP (MOBILE HOME PARK) ZONING CLASSIFICATION TO B-3 (GENERAL BUSINESS) ZONING CLASSIFICATION**

A motion was made by Clerk Lovejoy Roe, supported by Treasurer Doe to approve 1st Reading of Resolution 2015-43, Proposed Ordinance 2015-455, an Ordinance Amending Ordinance No. 74, Township Zoning Ordinance, to Rezone 953 East Michigan Avenue, Parcel K-11-10-205-039, From its Current MHP (Mobile Home Park) Zoning Classification to B-3 (General Business) Zoning Classification (see attached).

Mr. Joseph Lawson, Planning and Development Coordinator, stated that this is another property that by rezoning will help the Township move forward with the Master Plan for Re-development within the Township.

**CHARTER TOWNSHIP OF YPSILANTI
OCTOBER 6, 2015 REGULAR MEETING MINUTES
PAGE 4**

The motion carried as follows:

Eldridge:	Yes	S. Martin:	Yes	Stumbo:	Yes
Lovejoy Roe:	Yes	Doe:	Yes	M. Martin:	Yes

6. REQUEST TO APPROVE ANNUAL SENIOR NUTRITION AGREEMENT WITH WASHTENAW COUNTY, FUNDED THROUGH A FEDERAL GRANT AND TO AUTHORIZE SIGNING OF THE AGREEMENT

The motion was made by Clerk Lovejoy Roe, supported by Trustee Eldridge to approve the Request to Approve Annual Senior Nutrition Agreement with Washtenaw County, Funded Through a Federal Grant and to Authorize Signing of the Agreement (see attached).

The motion carried unanimously.

7. REQUEST AUTHORIZATION TO SIGN PURCHASE AGREEMENT WITH DTE FOR INSTALLATION OF ONE (1) OVERHEAD FED BLACK 135 WATT AUTOBAHN LED MOUNTED ON A 17'-5" CODE 48 ARM ON AN EXISTING WOOD POLE TO BE LOCATED AT THE WESTBOUND INTERSECTION OF MICHIGAN AVENUE AND DORSET IN THE AMOUNT OF \$658.28 BUDGETED IN LINE ITEM #101-956-000-926-050

A motion was made by Treasurer Doe, supported by Trustee Eldridge to approve the Request Authorization to Sign Purchase Agreement with DTE for Installation of One (1) Overhead FED Black 135 Watt Autobahn LED Mounted on a 17'-5" Code 48 Arm on an Existing Wood Pole to be Located at the Westbound Intersection of Michigan Avenue and Dorset in the Amount of \$658.28 Budgeted in Line Item #101-956-000-926-050 (see attached).

The motion carried unanimously.

8. REQUEST OF NEXUS GAS TRANSMISSION FOR AUTHORIZATION TO SURVEY TOWNSHIP OWNED PARCELS K-11-23-200-001, K-11-23-400-022 AND K-11-13-330-001

A motion was made by Clerk Lovejoy Roe, supported by Treasurer Doe to approve Request of Nexus Gas Transmission for Authorization to Survey Township Owned Parcels K-11-23-200-001, K-11-23-400-022, and K-11-13-330-001.

Eldridge:	No	S. Martin:	No	Stumbo:	No
Lovejoy Roe:	Yes	Doe:	Yes	M. Martin:	No

The motion failed.

**CHARTER TOWNSHIP OF YPSILANTI
OCTOBER 6, 2015 REGULAR MEETING MINUTES
PAGE 5**

- 9. SET PUBLIC HEARING DATE OF TUESDAY, NOVEMBER 17, 2015 AT APPROXIMATELY 7:00PM – CREATION OF LAKEVIEW #2 STREETLIGHT SPECIAL ASSESSMENT DISTRICT**

A motion was made by Clerk Lovejoy Roe, supported by Treasurer Doe to Set Public Hearing Date of Tuesday, November 17, 2015 at Approximately 7:00PM- Creation of Lakeview #2 Streetlight Special Assessment District (see attached).

The motion carried unanimously.

OTHER BUSINESS

- A. WAIVE THE FINANCIAL POLICY AND AUTHORIZE WRITTEN QUOTES FOR UPGRADE OF SIGNS AT THE CIVIC CENTER**

A motion was made by Treasurer Doe, supported by Clerk Lovejoy Roe to Waive the Financial Policy and Authorize Written Quotes for upgrade of signs at the Civic Center.

The motion carried unanimously.

AUTHORIZATION AND BIDS

- 1. REQUEST OF ERIC COPELAND, FIRE CHIEF, TO AWARD LOW BID FOR FIRE STATION HEADQUARTERS ROOF REPLACEMENT TO RAPID ROOFING IN THE AMOUNT OF \$49,950.00 BUDGETED IN LINE ITEM #206-970-000-971-008**

A motion was made by Clerk Lovejoy Roe, supported by Treasurer Doe to approve Request of Eric Copeland, Fire Chief, to Award Low Bid for Fire Station Headquarters Roof Replacement to Rapid Roofing in the Amount of \$49,950.00 Budgeted in Line Item #206-970-000-971-008, Subject to Review and Approval of Township Attorney.

The motion carried unanimously.

- 2. REQUEST OF MIKE RADZIK, OCS DIRECTOR, TO AWARD LOW BID FOR ASBESTOS ABATEMENT AND DEMOLITION OF RESIDENTIAL STRUCTURES LOCATED AT 2215 HARMON AND 2572 HEARTHSIDE IN THE AMOUNT OF \$28,075.00 BUDGETED IN LINE ITEM #101-950-000-969-011**

A motion was made by Clerk Lovejoy Roe, supported by Treasurer Doe to approve Request of Mike Radzik, OCS Director, to Award Low Bid for Asbestos Abatement and Demolition of Residential Structures Located at 2215 Harmon and 2572 Hearthside in the Amount of \$28,075.00 Budgeted in Line Item #101-950-000-969-011.

**CHARTER TOWNSHIP OF YPSILANTI
OCTOBER 6, 2015 REGULAR MEETING MINUTES
PAGE 6**

The motion carried unanimously.

- 3. REQUEST OF ERIC COPELAND, FIRE CHIEF, TO SEEK SEALED BIDS FOR THE REPAIR OF THE STORM DRAINS LOCATED IN THE NORTH PARKING LOT OF FIRE HEADQUARTERS AT 222 S. FORD BLVD.**

A motion was made by Clerk Lovejoy Roe, supported by Treasurer Doe to approve Request of Eric Copeland, Fire Chief, to Seek Sealed Bids for the Repair of the Storm Drains Located in the North Parking Lot of Fire Headquarters at 222 S. Ford Blvd.

The motion carried unanimously.

- 4. REQUEST OF ERIC COPELAND, FIRE CHIEF, TO SEEK SEALED BIDS FOR INSTALLATION OF FIBERGLASS INSULATION IN THE ATTIC AND SOFFIT AREA OF FIRE HEADQUARTERS AT 222 S. FORD BLVD.**

A motion was made by Treasurer Doe, supported by Trustee Eldridge to approve Request of Eric Copeland, Fire Chief, to Seek Sealed Bids for Installation of Fiberglass Insulation in the Attic and Soffit Area of Fire Headquarters at 222 S. Ford Blvd.

The motion carried unanimously.

ADJOURNMENT

A motion was made by Clerk Lovejoy Roe to adjourn, supported by Treasurer Doe .

The motion carried unanimously.

The meeting adjourned at 7:35 p.m.

Respectfully submitted,

Brenda L. Stumbo, Supervisor
Charter Township of Ypsilanti

Karen Lovejoy Roe, Clerk
Charter Township of Ypsilanti

**CHARTER TOWNSHIP OF YPSILANTI
2015 BUDGET AMENDMENT #12**

October 6, 2015

101 - GENERAL OPERATIONS FUND

Total Increase \$103,404.00

Increase budget for the 4 additional cameras installed for the special tax assessment in the Thurston neighborhood and the Sugarbrook playground totaling \$19,756. The original budget amendment approved June 17, 2014 was for 21 cameras at \$93,174.21. This will be funded by an Appropriation of Prior Year Fund Balance.

Revenues:	Prior Year Fund Balance	101-000-000-699.000	\$19,756.00
		Net Revenues	<u><u>\$19,756.00</u></u>
Expenditures:	Capital Outlay - Neighborhood Cameras	101-970-000-972.000	\$19,756.00
		Net Expenditures	<u><u>\$19,756.00</u></u>

Increase the revenue line for reimbursement from Habitat for property purchase from the Township and increase the expenditure line contribution - Land Bank to reimburse the expenditure line for the property purchases made by the Township. This will be funded by the reimbursement received from Habitat for Humanity.

Revenues:	Reimbursement - Habitat Humanity	101-000-000-688.100	\$83,648.00
		Net Revenues	<u><u>\$83,648.00</u></u>
Expenditures:	Contribution - Land Bank	101-950-000-969.011	\$83,648.00
		Net Expenditures	<u><u>\$83,648.00</u></u>

Motion to Amend the 2015 Budget (#12):

Move to increase the General Fund budget by \$103,404 to \$10,151,404 and approve the department line item changes as outlined.

RESOLUTION 2015-41

Amending the Code of Ordinances, Chapter 30, Article II Entitled Fire Prevention Code by Adoption of the 2012 Edition of the International Fire Prevention Code

Whereas, the Charter Township of Ypsilanti Board of Trustees recognizes the need for a modern, up-to-date fire code addressing conditions hazardous to life and property from fire and explosion hazards; the storage, handling and use of hazardous substances and materials; and the use and occupancy of buildings and premises; and

Whereas, the International Fire Code, 2012 Edition, is designed to meet these needs through model code regulations that safeguard public health and safety; and

Whereas, the International Fire Code, 2012 Edition, is fully compatible with the Michigan Building Code, Michigan Residential Code, Michigan Rehabilitation Code and the 2012 International Property Maintenance Code.

Whereas, the Township Fire Department recommends adoption of Ordinance 2015-453.

Now Therefore,

Be it resolved, that the Charter Township of Ypsilanti Board of Trustees hereby adopts by reference attached Ordinance No. 2015-453 amending the Code of Ordinances of the Charter Township of Ypsilanti, Article II, Fire Prevention Code.

PROPOSED ORDINANCE NO. 2015-453

*An Ordinance Amending the Code of Ordinances,
Charter Township of Ypsilanti, Chapter 30, Article II
Entitled Fire Prevention Code by Adoption of the
2012 Edition of the International Fire Prevention Code*

The Charter Township of Ypsilanti hereby **Ordains** that Chapter 30 of the Code of Ordinances for Ypsilanti Township, Article II entitled Fire Prevention Code is hereby amended as follows:

DELETE in its entirety the current Article II entitled Fire Prevention Code (Sections 30-26 through 30-31, inclusive).

ADD the following new provision:

A. Adoption by Reference.

A certain document, copies of which are on file with the office of the Township Clerk and the Bureau of Fire Prevention, being marked and designated as the "**International Fire Code, 2012 Edition, International Code Council,**" is adopted by reference, including Appendix Chapters A through J, and all references therein printed – except those section and appendices herein amended, deleted or added. This document shall be known and may be cited as the "**Fire Prevention Code of the Charter Township of Ypsilanti,**" regulating and governing conditions hazardous to life and property from the standpoint of fire and explosion and for defining the scope of authority of the chief of the fire department and the bureau of fire prevention.

B. Purpose of Article.

The purpose of this article is to provide for the prevention of fires and the protection of persons and property from exposure to the dangers of fire and explosion; to authorize the investigation of fires and the discovery of crime or other offenses in relation thereto; to require the razing, repair and alterations of building, and the clearing and improvement of premises which constitute a fire hazard or a menace to the peace, security or safety of persons or property; to control the use and occupancies of such premises; to provide for the transportation, use and storage of inflammable liquids, compressed gases, and corrosive liquids; to prohibit the use of certain fire extinguishers and fire extinguishing agents; to provide for the administration of this article; and to fix penalties for violation of the provisions of this article.

C. Code Available for Public Use and Inspection.

Complete printed copies of the **Fire Prevention Code** of the Charter Township of Ypsilanti and supplements, therein adopted, are available for public use and inspection at the office of the Township Clerk and at the office of the Bureau of Fire Prevention.

D. References in Code.

References in the **Fire Prevention Code** of the Charter Township of Ypsilanti and supplements to the word "*state*" shall mean the State of Michigan; reference to the word "*municipality*"

shall mean the Township of Ypsilanti; references to the term “*corporation counsel*” shall be held to mean the attorney for the township; reference to the term “*bureau of fire prevention*” shall mean the township fire department; and reference to the term “*fire official*” shall be held to mean the chief of the fire department or his authorized designee.

E. Code Revisions.

The following sections of the International Fire Code, 2012 Edition, International Code Council, are hereby revised.

Section 101.1 - insert Charter Township of Ypsilanti

Section 109.3 – delete in its entirety and replace with the following provision:

Section 109.3. Persons who shall violate a provision of this code or shall fail to comply with any of the requirements thereof or who shall erect, install, alter, repair or do work in violation of the approved construction documents or directive of the code official, or of a permit or certificate used under the infraction, and shall be subject to a fine as follows:

- a. The fine for any first violation of Article II shall be \$100.00.
- b. The fine for any violation which the violator has, within the past two years, been found in violation of once before, shall be \$250.00.
- c. The fine for any violation which the violator has, within the past two years, been found in violation of twice before, shall be \$500.00.

The imposition of one penalty for any violation shall not excuse the violations or permit it to continue. All such persons shall be required to correct or remedy such situation or defects within a reasonable time, and, when not otherwise specified, each act or violation and every day upon which such violation shall occur shall constitute a separate offense.

The application of the penalties of this section shall not be held to prevent the enforced removal of prohibited conditions by injunctive or other relief.

Each day that a violation continues after due notice has been served shall be deemed a separate violation.

Section 111.4 – insert \$100 or more than \$500

Section 901.2 – Fire Sprinkler Plan Submittal (Added to read)

All fire sprinkler plans shall be submitted to the *fire official* for review. The *fire official* may request review of the sprinkler plans by a third party. The third party shall be included on a list of companies approved by the Charter Township of Ypsilanti Fire Prevention Bureau. The Charter Township of Ypsilanti Fire Prevention Bureau shall witness all required tests and field inspections of all fire sprinkler systems.

- a. A list of approved companies will be available in the Fire Prevention Bureau and the Office of Community Standards.
- b. No company will be allowed to review its own plans.

Section 906.1 - Residential Fire Extinguisher Requirements Rental Units. (Added to read)

- a. It shall be the responsibility of the owner(s) of single family and multiple family rental units to provide each living unit with a portable fire extinguisher.
- b. The fire extinguisher shall have a minimum 1A-10BC rating or higher, and shall be mounted in a readily accessible location within each dwelling unit. Each extinguisher shall be tagged to include a maintenance and inspection record and must be operable at all times.
- c. It shall be the owner's responsibility to maintain the extinguisher in accordance with NFPA 10, and such maintenance shall include, but is not limited to, recharging the extinguisher of the unit which was discharged when attempting to extinguish a documented fire. For the purpose of this section, a documented fire shall mean any fire that the Ypsilanti Township Fire Department has responded to and/or has a record of. In all other cases it shall be the responsibility of the resident to recharge the extinguisher.
- d. The resident of a single family or multiple family rental unit shall be responsible to advise the building owner, or his designated agent, whenever a required fire extinguisher is missing, damaged, discharged or in need of service.
- e. Anyone tampering with, damaging or interfering with the effectiveness of a fire extinguisher shall be in violation of this code.

Section 907.2 - Minimum Smoke Detection Requirements Rental Units. (Added to read)

- a. Each apartment, suite, or sleeping area of every single or multiple dwelling units shall be provided with a minimum of one smoke detector capable of sensing visible or invisible products of combustion.
- b. The smoke detector shall be approved or listed by recognized or independent testing laboratories and, when actuated, shall provide an alarm suitable to warn the occupants within the individual dwelling unit.
- c. A minimum of one smoke detector shall be located in the immediate area of all sleeping quarters.
- d. All single family and multiple dwelling units, including duplexes, shall comply with this section.
- e. It shall be the responsibility of the owner(s) of each rental unit to install and maintain in operating condition smoke detectors in each dwelling unit as herein provided.

f. All devices, combination of devices and equipment required herein are to be installed in conformance with the Michigan Building and Residential Codes and this section.

g. At least one smoke detector shall be installed to protect each sleeping area. A sleeping area is defined as the area or areas of the family living unit in which the bedrooms or sleeping rooms are located. When bedrooms ordinarily used for sleeping are separated by other used areas, such as kitchens or living rooms, but not bathrooms or closets, they shall be considered as separate sleeping areas for the purpose of this section.

F. Geographic Limits Referred to in Certain Sections of the Code.

The geographic limits referred to in certain sections of the 2012 International Fire Code are hereby established as follows:

Section 5704.2.9.6.1 (geographic limits in which the storage of Class I and Class II liquids in above-ground storage tanks outside of buildings is prohibited): *Storage of greater than 50 gallons is prohibited within 50 feet of a structure.*

Section 5706.2.4.4 (geographic limits in which the storage of Class I and Class II liquids in above-ground ground storage tanks is prohibited): *Amend to add the following language:*

- a. *An above ground storage tank shall not be erected less than 300 feet (92 meters) from any of the following:*
 - i. *a mineshaft.*
 - ii. *an air escape shaft for a mine.*
 - iii. *a school*
 - iv. *a church*
 - v. *a hospital*
 - vi. *a theater*
 - vii. *assembly occupancies for 50 or more persons.*
- b. *The above ground storage tank, loading operation, or unloading operation shall not be installed closer than 25 feet (7.6 meters) plus 1 inch (25 millimeters) per 1,000 volts, measured horizontally from the nearest conductor or power lines, except that a service entrance and service line may be closer than 25 feet (7.6 meters), but shall not be over a tank loading or unloading area.*

Section 5806.2 (geographic limits in which the storage of flammable cryogenic fluids in stationary containers is prohibited): *Amend to add the following language:*

- a. *Stationary containers with storage greater than 45 gallons is prohibited within 50 feet of the following:*
 - i. *Places of public assembly*
 - ii. *Non-ambulatory patient areas*
- b. *Stationary containers with storage greater than 45 gallons is prohibited within 15 feet of the following:*
 - i. *Combustible materials such as paper, leaves, weeds, dry grass or debris exposure hazards*

- c. *Stationary containers with storage greater than 45 gallons is prohibited within 10 feet of the following:*
 - i. *Air intakes*

- d. *Stationary containers with storage greater than 45 gallons is prohibited within 5 feet of the following:*
 - i. *Lot lines*

Section 6104.2 (geographic limits in which the storage of liquefied petroleum gas is restricted for the protection of heavily populated or congested areas): *Amend to add the following language:*

For the protection of heavily populated and congested areas, the maximum aggregate capacity of any installation of liquefied petroleum gas shall not exceed a water capacity of 2,000 gallons within 50 feet (15.2 meters) of a structure.

G. Rights and Remedies are Cumulative.

The rights and remedies provided herein are cumulative and in addition to any other remedies provided by law.

H. Severability Clause.

That if any section, subsection, sentence, clause or phrase of this ordinance is, for any reason, held to be unconstitutional, such decision shall not affect the validity of the remaining portions of this ordinance. The Charter Township of Ypsilanti hereby declares that it would have passed this ordinance, and each section, subsection, clause or phrase thereof, irrespective of the fact that any one or more sections, subsection, sentences, clauses or phrases by declared unconstitutional.

I. Publication.

This Ordinance shall be published in a newspaper of general circulation as required by law.

J. Effective Date.

This Ordinance shall be effective upon publication in a newspaper of general circulation as required by law.

I, Karen Lovejoy Roe, Clerk of the Charter Township of Ypsilanti, County of Washtenaw, State of Michigan hereby certify approval of the first reading of Proposed Ordinance No. 2015-453 by the Charter Township of Ypsilanti Board of Trustees assembled at a regular meeting held on October 6, 2015. The second reading is scheduled to be heard on October 20, 2015.

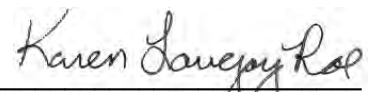

Karen Lovejoy Roe, Clerk
Charter Township of Ypsilanti

RESOLUTION 2015-42

Rezoning of 2590 East Michigan Avenue, Parcel K-11-01-300-004, From its Current MHP (Mobile Home Park) District Zoning Classification to B-3 (General Business) District Classification

Whereas, at its regularly scheduled meeting held **August 25, 2015**, the Charter Township of Ypsilanti (Township) Planning Commission (Commission) recommended that the Township Board approve a rezoning request for a certain parcel of property comprising 5.55 acres, commonly identified as 2590 East Michigan Avenue, Parcel ID K-11-01-300-004, from the MHP (mobile home park) zoning district to the B-3 (general business district) zoning district; and

Whereas, the rezoning request is consistent with the Township's current Master Plan; and

Whereas, proposed Ordinance No. 2015-454 rezones 2590 East Michigan Avenue, Parcel ID K-11-01-300-004, from MHP District to B-3 District zoning classification; and

Whereas, the Township Board of Trustees agrees that the rezoning is appropriate.

Now Therefore,

Be it resolved that the Charter Township of Ypsilanti hereby adopts and incorporates by reference Ordinance No. 2015-454 attached hereto, by reference, in its entirety.

ORDINANCE 2015-454

***An Ordinance Amending Ordinance No. 74,
Township Zoning Ordinance, So As To Rezone
2590 East Michigan Avenue, being Parcel ID K-11-01-300-004,
From Its Current MHP (mobile home park) District Zoning
Classification To B-3 (general business) District Zoning Classification***

The Charter Township of Ypsilanti hereby ordains that

Ordinance No. 74, adopted May 18, 1994, shall be amended as follows:

Real Property consisting of 5.55 acres of land located at 2590 East Michigan Avenue, also known as Parcel ID K-11-01-300-004, and more particularly described as follows:

See attached legal description labeled "Attachment A" shall be rezoned from its current MHP (mobile home park) District zoning classification to the B-3 (general business) District zoning classification.

The Zoning Map, as incorporated by reference, in the Charter Township of Ypsilanti Zoning Ordinance is hereby amended by the rezoning of the afore-described parcel of property from its MHP District zoning classification to the B-3 District zoning classification.

Severability

In the event that any one or more sections, provisions, phrases or words of this ordinance shall be found to be invalid by a Court of competent jurisdiction, such holding shall not affect the validity nor the enforceability of the remaining sections, provisions, phrases or words of this Ordinance unless expressly so determined by a Court of competent jurisdiction.

Non Exclusivity

The prohibitions and penalties provided for in this Ordinance shall be in addition to, and not exclusive of, other prohibitions and penalties provided for by other law, ordinance, or rule/regulation.

Publication

This Ordinance shall be published in a newspaper of general circulation as required by law.

Effective date

This Ordinance shall become effective upon publication in a newspaper of general circulation as required by law.

I, Karen Lovejoy Roe, Clerk of the Charter Township of Ypsilanti, County of Washtenaw, State of Michigan hereby certify approval of the first reading of Proposed Ordinance No. 2015-454 by the Charter Township of Ypsilanti Board of Trustees assembled at a regular meeting held on October 6, 2015. The second reading is scheduled to be heard on October 20, 2015.



Karen Lovejoy Roe, Clerk
Charter Township of Ypsilanti

RESOLUTION 2015-43

Rezoning of 953 East Michigan Ave, Parcel K-11-10-205-039, From Its Current MHP (Mobile Home Park) District Zoning Classification to B-3 (General Business) District Zoning Classification

Whereas, at its regularly scheduled meeting held **August 25, 2015**, the Charter Township of Ypsilanti (Township) Planning Commission (Commission) recommended that the Township Board approve a rezoning request for a certain parcel of property comprising 6.52 acres, commonly identified as 953 East Michigan Avenue, Parcel ID K-11-10-205-039, from the MHP (mobile home park) zoning district to the B-3 (general business district) zoning district; and

Whereas, the rezoning request is consistent with the Township's current Master Plan; and

Whereas, proposed Ordinance No. 2015-455 rezones 953 East Michigan Avenue, Parcel ID K-11-10-205-039, from MHP District to B-3 District zoning classification; and

Whereas, the Township Board of Trustees agrees that the rezoning is appropriate.

Now Therefore,

Be it resolved that the Charter Township of Ypsilanti hereby adopts and incorporates by reference Ordinance No. 2015-455 attached hereto, by reference, in its entirety.

PROPOSED ORDINANCE 2015-455

***An Ordinance Amending Ordinance No. 74,
Township Zoning Ordinance, So As To Rezone
953 East Michigan Avenue, being Parcel ID K-11-10-205-039,
From Its Current MHP (mobile home park) District Zoning
Classification To B-3 (general business) District Zoning Classification***

The Charter Township of Ypsilanti hereby ordains that

Ordinance No. 74, adopted May 18, 1994, shall be amended as follows:

Real Property consisting of 6.52 acres of land located at 953 East Michigan Avenue, also known as Parcel ID K-11-10-205-039, and more particularly described as follows:

See attached legal description labeled "Attachment A" shall be rezoned from its current MHP (mobile home park) District zoning classification to the B-3 (general business) District zoning classification.

The Zoning Map, as incorporated by reference, in the Charter Township of Ypsilanti Zoning Ordinance is hereby amended by the rezoning of the afore-described parcel of property from its MHP District zoning classification to the B-3 District zoning classification.

Severability

In the event that any one or more sections, provisions, phrases or words of this ordinance shall be found to be invalid by a Court of competent jurisdiction, such holding shall not affect the validity nor the enforceability of the remaining sections, provisions, phrases or words of this Ordinance unless expressly so determined by a Court of competent jurisdiction.

Non Exclusivity

The prohibitions and penalties provided for in this Ordinance shall be in addition to, and not exclusive of, other prohibitions and penalties provided for by other law, ordinance, or rule/regulation.

Publication

This Ordinance shall be published in a newspaper of general circulation as required by law.

Effective date

This Ordinance shall become effective upon publication in a newspaper of general circulation as required by law.

I, Karen Lovejoy Roe, Clerk of the Charter Township of Ypsilanti, County of Washtenaw, State of Michigan hereby certify approval of the first reading of Proposed Ordinance No. 2015-455 by the Charter Township of Ypsilanti Board of Trustees assembled at a regular meeting held on October 6, 2015. The second reading is scheduled to be heard on October 20, 2015.



Karen Lovejoy Roe, Clerk
Charter Township of Ypsilanti

COUNTY OF WASHTENAW, MICHIGAN

Agreement for Subaward of Federal Financial Assistance

The COUNTY OF WASHTENAW is a recipient of federal financial assistance grant dollars. These funds are received directly from the federal government and indirectly from the State of Michigan and several local entities. The County sometimes passes through a portion of this federal financial assistance to other organizations located within (or in the vicinity of) the geographical boundaries of the County to assist them in carrying out the objectives of the applicable federal grant or program.

AGREEMENT is made this 1st day of October, 2015, by the COUNTY OF WASHTENAW, a municipal corporation, with offices located in the County Administration Building, 220 North Main Street, Ann Arbor, Michigan, as the pass-through entity (hereinafter referred to as the County) and, Charter Township of Ypsilanti located at 7200 S. Huron River Dr., Ypsilanti, MI. 48198 on behalf of Ypsilanti Township Community Center (hereinafter often referred to as the Subrecipient).

This agreement is a subaward of federal financial assistance by the County to the Subrecipient intended to assist, stimulate, or support the Subrecipient in carrying out its allowable activities under the Special Programs for the Aging Title III, Part C Nutrition as requested by the Subrecipient in its application to the County for federal financial assistance.

Flow of Federal Financial Assistance in this Subaward Agreement

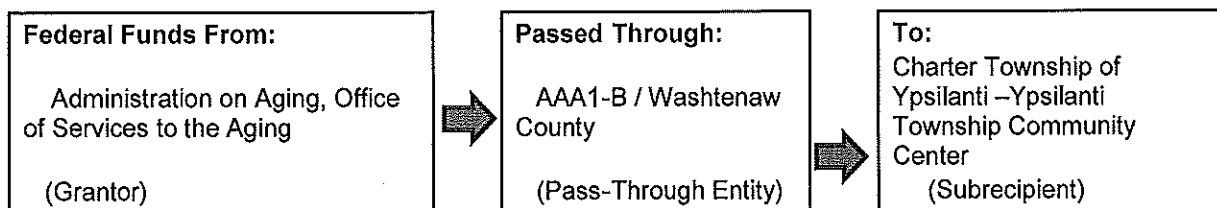

ARTICLE I – REQUIRED DATA ELEMENTS

(As detailed in Section 200.331 of the Uniform Administrative Requirements, Cost Principles, and Audit Requirements for Federal Awards (2 CFR Chapter I, and Chapter II, Parts 200, 215, 220, 225, 230) issued December 26, 2013 by the Executive Office of the President, Office of Management and Budget, hereinafter referred to as the Uniform Guidance.)

Subrecipient Name (must match registered name in DUNS)	Ypsilanti Township Community Center
Subrecipient DUNS Number	
Federal Award Identification Number (FAIN)	16-9052-CH
Federal Award Date (the date when the federal award is signed by the authorized official of the federal awarding agency)	October 1 st , 2015
Subaward Period of Performance (start and end date)	October 1 st , 2015 through September 30 th , 2016
Amount of Federal Funds Obligated by this Agreement	\$15,000.00

Total Amount of Federal Funds Obligated to the Subrecipient	\$15,000.00
Total Amount of the Federal Award	\$15,000.00
Federal Award Project Description (as required to be responsive to the Federal Funding Accountability and Transparency Act (FFATA) described in Title 2 Code of Federal Regulations Part 170)	Congregate meals for program participants ≥60 years old.
Name of Federal Awarding Agency	Administration on Aging, Office of Services to the Aging
Name of County (Pass-Through Entity)	Washtenaw County
Name and Contact Information for Awarding Official	Jamila Rahman, rahmanj@ewashtenaw.org
CFDA Number and Name	93.045; Special Programs for the Aging Title III, Part Nutrition Services
Is this Subaward for Research and Development? (answer Yes or No)	No
Indirect Cost Rate for the Federal Award (either an approved federally recognized indirect cost rate negotiated between the Subrecipient and the federal government or, if no such rate exists, either a rate negotiated between the County and Subrecipient or a de minimus indirect cost rate of 10% of modified total direct costs may be used). Subrecipient may choose to charge only direct costs to this agreement.	N/A

In consideration of the promises below, the parties mutually agree as follows:

ARTICLE II - SCOPE OF SERVICES

The Contractor will be responsible for administering the congregate meals programs for the Ypsilanti Township Community Center located at 2025 E. Clark Road, Ypsilanti, MI. 48198 in accordance with local, state, and federal requirements as outlined in Attachment D, *Scope of Services*.

ARTICLE III - PAYMENT AND CASH MANAGEMENT

The County will pay the Subrecipient an amount not to exceed **fifteen thousand dollars (\$15,000.00)**. The County agrees to make payments in quarterly installments in accordance with the budget and timeline in Attachment E, unless otherwise approved in writing by the parties. If at the end of the term of this Agreement there are unexpended portions of the contract amount, the unexpended funds will be retained by the County for reallocation to other purposes.

If the County is paid in advance by the federal awarding agency under the above named federal assistance award, the Subrecipient may also be paid in advance if it meets the requirements in Section 1 below.

Section 1 - Cash Advances. The Subrecipient may request an advance of funds under this agreement if it maintains or demonstrates the willingness to maintain both:

1. written procedures that minimize the time elapsing between the transfer of funds from the County and the subsequent disbursement of the funds by the Subrecipient,
2. financial management systems that meet the standards for fund control and accountability as defined in Section 200.305 of the Uniform Guidance.

Requests for advance of funds must be limited to the minimum amount needed and must be timed to be in accordance with the actual, immediate cash requirements of the Subrecipient in carrying out the terms of this agreement. The timing and amount of the advance must be as close as is "administratively feasible" to the actual disbursement to be made by the Subrecipient.

Section 2 - Reimbursement. If the Subrecipient does not meet the requirements in Section 1 above, it shall submit periodic reimbursement requests to the County. This may be done on a monthly or quarterly basis. The reimbursement request shall be accompanied by the agreed upon financial and programmatic reports. The County shall pay the Subrecipient within 30 calendar days after the receipt of the reimbursement request and the agreed upon financial/programmatic reports, unless the County reasonably believes the reimbursement request to be improper.

ARTICLE IV - REPORTING OF SUBRECIPIENT

Section 1 - The Subrecipient is to report to *Andrea Plevak* and will cooperate and confer with him/her as necessary to insure satisfactory work progress.

Section 2 - The Subrecipient shall submit financial reports *QUARTERLY* to *Jamila Rahman, Human Services Program Specialist*. The Subrecipient shall submit programmatic reports *QUARTERLY* to *Jamila Rahman, Human Services Program Specialist*

Section 3 - All reports, estimates, memoranda and documents submitted by the Subrecipient must be dated and bear the Subrecipient's name. Financial reports shall be submitted in a timely manner to the County and shall be in agreement with the amounts shown in the Subrecipient's financial system and shall be supported by appropriate documentation (payroll records, invoices, etc.). Final financial and programmatic reports shall be submitted by the Subrecipient within 30 days of the end of this agreement unless an extension of time is granted in writing by the County.

Section 4 - The Subrecipient agrees to only incur costs under this agreement which are eligible under the Cost Principles detailed in Section 200.400-475 of the Uniform Guidance.

Section 5 - The Subrecipient shall retain all reports, records and supporting documentation pertaining to this agreement for a period of three years from the date of submission of the final expenditure report and shall make them available to the County and the federal awarding agency upon request.

Section 6 - All reports made in connection with these services are subject to review and final approval by the County Administrator.

Section 7 - The County may review and inspect the Subrecipient's activities during the term of this agreement.

Section 8 - When applicable, the Subrecipient will submit a final, written report to the County Administrator.

Section 9 - After reasonable notice to the Subrecipient, the County may review any of the Subrecipient's internal records, reports, or insurance policies.

Section 10 - The Subrecipient shall disclose in writing to the County any potential conflict of interest it has related to the County or this agreement.

Section 11 - The Subrecipient shall disclose in writing to the County in a timely manner all violations of Federal criminal law involving fraud, bribery, or gratuity violations potentially affecting this agreement.

Section 12 - The Subrecipient shall report to the County in a timely manner if any adverse or problematic situations arise between reporting deadlines describing the nature of the problem and what is being done to address it.

ARTICLE V - TERM

This agreement begins on *October 1st, 2015* and ends on *September 30th, 2016 with an option to extend an additional 3 year(s)*. No costs eligible under this agreement shall be incurred by the Subrecipient before or after these dates, except with prior written approval of the County. Both parties will agree in writing prior to the end of the contract to extend agreement for one year.

ARTICLE VI- RESPONSIBILITIES OF THE SUBRECIPIENT

Section 1 - The Subrecipient agrees to comply with all applicable federal, State, and local regulations including the Uniform Guidance. The Subrecipient agrees to comply with the management systems standards (financial management (Sections 200.302-304), procurement (Sections 200.317-326), and property management (Sections 200.310-316)) of the Uniform Guidance.

Section 2 - The Subrecipient agrees to have performed a Single Audit of its federal expenditures if it reaches the Single Audit dollar threshold in federal expenditures during its fiscal year as detailed in Section 200.501 of the Uniform Guidance. The County reserves the right to perform or cause to be performed additional audits if it deems such to be necessary to insure compliance with the terms of this agreement or to determine the eligibility of the reported expenditures for reimbursement.

Section 3 - The Subrecipient agrees to comply with the provisions of the Byrd Amendment (Public Law 101-121, Section 319 - 31 U.S. Code Section 1352) which prohibits the use of federal funds by the recipient or subrecipient of a Federal contract, grant, loan, or cooperative agreement to pay any person to influence or attempt to influence an officer or employee of any agency, a Member of Congress, an officer or employee of Congress, or an employee of a Member of Congress in connection with the federal funds awarded under this agreement.

Section 4 - The Subrecipient agrees to comply with the provisions of the Stevens Amendment (Section 8136 of the Department of Defense Appropriations Act - Public Law 100-463) which stipulates that when issuing statements, press releases, requests for proposals, bid solicitations, and other documents describing projects or programs funded in whole or in part with federal money, all grantees receiving federal funds, including but not limited to state and local governments, shall clearly state (1) the percentage of the total cost of the program or project which will be financed with federal money, (2) the dollar amount of federal funds for the

project or program, and (3) the percentage and dollar amount of the total costs of the project or program that will be funded by non-governmental sources.

Section 5 - In addition to this agreement, the Subrecipient shall complete, sign, and submit to the County the following documents which are attached as part of this agreement:

1. Standard Assurances (Attachment A)
2. Certifications Regarding Lobbying; Debarment, Suspension and Other Responsibility Matters; and Drug-Free Workplace Requirements (Attachment B)
3. Audit Certification (Attachment C)

ARTICLE VII – SUSPENSION OF FUNDING

The County may suspend funding to the Subrecipient, in whole or in part, or other measures may be imposed for any of the following reasons:

1. Failure to expend funds in a timely manner consistent with the agreement milestones, guidance, and assurances.
2. Failure to comply with the requirements or statutory objectives of federal or state law.
3. Failure to follow agreement requirements or special conditions.
4. Proposal or implementation of substantial plan changes to the extent that, if originally submitted, the application would not have been approved for funding.
5. Failure to submit required reports.
6. Filing of a false certification on the application or other report or document.
7. Failure to adequately manage, monitor or direct the activities of its subrecipients that are funded under this agreement.

Before taking action, the County will provide the Subrecipient reasonable notice of intent to impose corrective measures and will make every effort to resolve the problem informally.

The County reserves the right to recommend to the federal government that the Subrecipient be suspended or debarred in the case of sustained significant noncompliance by the Subrecipient with the award provisions.

ARTICLE VIII- PERSONNEL

Section 1 - The Subrecipient will provide the required services and will not subaward or assign the services without the County's written approval.

Section 2 - The Subrecipient will not hire any County employee for any of the required services without the County's written approval.

Section 3 - The parties agree that all work done under this agreement shall be completed in the United States and that none of the work will be partially or fully completed by either an offshore entity or offshore business interest either owned or affiliated with the Subrecipient. For purposes of this agreement, the term, "offshore" refers to any area outside the contiguous United States, Alaska or Hawaii.

ARTICLE IX-INDEPENDENT CONTRACTOR

Contractor and the County shall, at all times, be deemed to be independent contractors and nothing herein shall be construed to create or imply that there exists between the parties a partnership, joint venture or other business organization. Contractor shall hold no authority,

express or implied, to commit, obligate or make representations on behalf of the County and shall make no representation to others to the contrary.

Nothing herein is intended nor shall be construed for any purpose as creating the relationship of employer and employee or agent and principal between the parties. Except as otherwise specified in this contract, Contractor retains the sole right and obligation to direct, control or supervise the details and means by which the services under this contract are provided.

Contractor shall not be eligible for, or participate in, any insurance, pension, workers' compensation insurance, profit sharing or other plans established for the benefit of the County's employees. Contractor shall be solely responsible for payment of all taxes arising out of the Contractor's activities in connection with this Agreement, including, without limitation, federal and state income taxes, social security taxes, unemployment insurance taxes and any other tax or business license fees as required. The County shall not be responsible for withholding any income or employment taxes whatsoever on behalf of the Contractor.

ARTICLE X - INDEMNIFICATION AGREEMENT

The Subrecipient will protect, defend and indemnify the County, its officers, agents, servants, volunteers and employees from any and all liabilities, claims, liens, fines, demands and costs, including legal fees, of whatsoever kind and nature which may result in injury or death to any persons, including the Subrecipient's own employees, and for loss or damage to any property, including property owned or in the care, custody or control of the County in connection with or in any way incident to or arising out of the occupancy, use, service, operations, performance or non-performance of work in connection with this agreement resulting in whole or in part from negligent acts or omissions of Subrecipient, any subcontractor of the Subrecipient, or any employee, agent or representative of the Subrecipient or any subcontractor of the Subrecipient.

ARTICLE XI- INSURANCE REQUIREMENTS

The Subrecipient will maintain at its own expense during the term of this Agreement, the following insurance:

1. Workers' Compensation Insurance with Michigan statutory limits and Employers Liability Insurance with a minimum limit of \$100,000 each accident for any employee.
2. Commercial General Liability Insurance with a combined single limit of \$1,000,000 each occurrence for bodily injury and property damage. The County and the Area Agency on Aging 1-B shall be added as "additional insured" on general liability policy with respect to the services provided under this agreement.
3. Automobile Liability Insurance covering all owned, hired and non-owned vehicles with Personal Protection Insurance and Property Protection Insurance to comply with the provisions of the Michigan No Fault Insurance Law, including residual liability insurance with a minimum combined single limit of \$1,000,000 each accident for bodily injury and property damage.
4. Professional Liability coverage with a minimum limit of \$1,000,000 each occurrence. The County shall be added as "additional insured" on Professional liability policy with respect to the services provided under this agreement. The

additional insured provision does not apply to agreements with Architects, Architectural firms, Engineers or Engineering firms.

Insurance companies, named insureds and policy forms may be subject to the approval of the County Administrator, if requested by the County Administrator. Such approval shall not be unreasonably withheld. Insurance policies shall not contain endorsements or policy conditions which reduce coverage provided to The County. Subrecipient shall be responsible to the County or insurance companies insuring the County for all costs resulting from both financially unsound insurance companies selected by Subrecipient and their inadequate insurance coverage. Subrecipient shall furnish the County Administrator with satisfactory certificates of insurance or a certified copy of the policy, if requested by the County Administrator.

No payments will be made to the Subrecipient until the current certificates of insurance have been received and approved by the Administrator. If the insurance as evidenced by the certificates furnished by the Subrecipient expires or is canceled during the term of the agreement, services and related payments will be suspended. Subrecipient shall furnish certification of insurance evidencing such coverage and endorsements at least ten (10) working days prior to commencement of services under this agreement. Certificates shall be addressed to the County *c/o: Office of Community and Economic Development P. O. Box 915, Ypsilanti, MI 48197*, and shall provide for written notice to the Certificate holder of cancellation of coverage.

ARTICLE XII - COMPLIANCE WITH LAWS AND REGULATIONS

The Subrecipient will comply with all federal, state and local regulations, including but not limited to all applicable OSHA/MIOSHA requirements and the Americans with Disabilities Act.

The Subrecipient agrees to maintain the proper organizational status (such as 501 (c)(3) if needed) to be eligible to receive federal financial assistance under this grant, including proper licensure, registration, etc. Subrecipient agrees to keep itself in the same legal position/mode of organization as when it entered into this agreement.

ARTICLE XIII - INTEREST OF SUBRECIPIENT AND COUNTY

The Subrecipient promises that it has no interest which would conflict with the performance of services required by this agreement. The Subrecipient also promises that, in the performance of this agreement, no officer, agent, employee of the County, or member of its governing bodies, may participate in any decision relating to this agreement which affects his/her personal interest or the interest of any corporation, partnership or association in which he/she is directly or indirectly interested or has any personal or pecuniary interest. However, this paragraph does not apply if there has been compliance with the provisions of Section 3 of Act No. 317 of the Public Acts of 1968 and/or Section 30 of Act No. 156 of Public Acts of 1851, as amended by Act No. 51 of the Public Acts of 1978, whichever is applicable.

ARTICLE XIV - CONTINGENT FEES

The Subrecipient promises that it has not employed or retained any company or person, other than bona fide employees working solely for the Subrecipient, to solicit or secure this agreement, and that it has not paid or agreed to pay any company or person, other than bona

bona fide employees working solely for the Subrecipient, any fee, commission, percentage, brokerage fee, gifts or any other consideration contingent upon or resulting from the award or making of this agreement. For breach of this promise, the County may cancel this agreement without liability or, at its discretion, deduct the full amount of the fee, commission, percentage, brokerage fee, gift or contingent fee from the compensation due the Subrecipient.

ARTICLE XV - EQUAL EMPLOYMENT OPPORTUNITY

The Subrecipient will not discriminate against any employee or applicant for employment because of race, creed, color, sex, sexual orientation, national origin, physical handicap, age, height, weight, marital status, veteran status, religion and political belief (except as it relates to a bona fide occupational qualification reasonably necessary to the normal operation of the business).

The Subrecipient will take affirmative action to eliminate discrimination based on sex, race, or a handicap in the hiring of applicant and the treatment of employees. Affirmative action will include, but not be limited to: Employment; upgrading, demotion or transfer; recruitment advertisement; layoff or termination; rates of pay or other forms of compensation; selection for training, including apprenticeship.

The Subrecipient agrees to post notices containing this policy against discrimination in conspicuous places available to applicants for employment and employees. All solicitations or advertisements for employees, placed by or on the behalf of the Subrecipient, will state that all qualified applicants will receive consideration for employment without regard to race, creed, color, sex, sexual orientation, national origin, physical handicap, age, height, weight, marital status, veteran status, religion and political belief.

ARTICLE XVI - LIVING WAGE

The parties understand that the County has enacted a Living Wage Ordinance that requires covered vendors who execute a service or professional service agreement with the County to pay their employees under that agreement, a minimum of either \$12.00 per hour with benefits or \$14.07 per hour without benefits. Agreementor agrees to comply with this Ordinance in paying its employees. The Subrecipient understands and agrees that an adjustment of the living wage amounts, based upon the Health and Human Services poverty guidelines, will be made on or before April 30, 2016 and annually thereafter which amount shall be automatically incorporated into this agreement. County agrees to give the Subrecipient thirty (30) days written notice of such change. The Subrecipient agrees to post a notice containing the County's Living Wage requirements at a location at its place of business accessed by its employees.

ARTICLE XVII - ASSIGNS AND SUCCESSORS

This agreement is binding on the County and the Subrecipient, their successors and assigns. Neither the County nor the Subrecipient will assign or transfer its interest in this agreement without the written consent of the other.

ARTICLE XVIII - TERMINATION OF AGREEMENT

Termination without cause. Either party may terminate the agreement by giving thirty (30) days written notice to the other party. Upon any such termination, the Subrecipient agrees to return to the County any funds not authorized for use, and the County shall have no further obligation to reimburse the Subrecipient. Upon termination of the agreement, the Subrecipient shall submit documentation, in a format specified by the County, to formally end its participation in the agreement.

ARTICLE XIX - EQUAL ACCESS

The Subrecipient shall provide the services set forth in the Scope of Service section of this agreement without discrimination on the basis of race, color, religion, national origin, sex, sexual orientation, marital status, physical handicap, or age.

ARTICLE XX - OWNERSHIP OF DOCUMENTS AND PUBLICATION

All documents developed as a result of this agreement will be freely available to the public. None may be copyrighted by the Subrecipient. During the performance of the services, the Subrecipient will be responsible for any loss of or damage to the documents while they are in its possession and must restore the loss or damage at its expense. Any use of the information and results of this agreement by the Subrecipient must reference the project sponsorship by the County. Any publication of the information or results must be co-authored by the County.

ARTICLE XXI - PAYROLL TAXES

The Subrecipient is responsible for all applicable state and federal social security benefits and unemployment taxes for its employees and agrees to indemnify and protect the County against such liability.

ARTICLE XXII - PRACTICE AND ETHICS

The parties will conform to the code of ethics of their respective national professional associations.

ARTICLE XXIII - CHANGES IN SCOPE OR SCHEDULE OR SERVICES

Changes mutually agreed upon by the County and the Subrecipient, will be incorporated into this agreement by written amendments signed by both parties.

Unilateral modification of the agreement may take place by the County if the underlying programmatic legislation or regulations are changed by the federal government. If this unilateral modification is objectionable to the Subrecipient, it may withdraw from receiving further federal financial assistance under this agreement by giving (thirty) 30 days written notice to the County.

The Subrecipient agrees to inform the County in writing concerning any proposed changes of dates, budget, or services indicated in this agreement, as well as changes of address or personnel affecting this agreement. Changes in dates, budget, or services are subject to prior written approval of the County.

ARTICLE XXIV - CHOICE OF LAW AND FORUM

This agreement is to be interpreted by the laws of the State of Michigan. The parties agree that the proper forum for any disputes or litigation arising out of this agreement is in Washtenaw County, Michigan.

The County and the Subrecipient agree that each must seek its own legal representative and bear its own costs, including judgments, in any litigation that may arise from performance of this contract. It is specifically understood and agreed that neither party will indemnify the other party in such litigation. This is not to be construed as a waiver of governmental immunity for either party.

ARTICLE XXV - EXTENT OF AGREEMENT

This written agreement, including any attachments thereto, represents the entire agreement between the parties and supersedes all prior representations, negotiations or agreements whether written or oral.

ARTICLE XXVI – PRIVACY / THIRD PARTIES

This agreement is solely between the County and Subrecipient. No other parties are part of this agreement. This agreement is not intended to make any person or entity, not a party to this agreement, a third party beneficiary hereof or to confer on a third party any rights or obligations enforceable in their favor.

ARTICLE XXVII - SEVERABILITY

The invalidity or unenforceability of any provisions of this agreement shall not affect the validity or enforceability of any other provision of this agreement, which shall remain in full force and effect.

ARTICLE XXVIII - NOTICES

Communication notices for this agreement may be delivered via electronic mail, U.S. mail, hand delivery, or fax.

The individual or officer signing this agreement certifies by his or her signature that he or she is authorized to sign this agreement on behalf of the organization he or she represents. By signing this agreement, the County and the Subrecipient agree to comply with all of the requirements specified in this agreement.

ATTESTED TO:

WASHTENAW COUNTY (Pass-Through Entity)

By: _____
Lawrence Kestenbaum (DATE)
County Clerk/Register

By: _____
Verna J. McDaniel (DATE)
County Administrator

APPROVED AS TO CONTENT:

CHARTER TOWNSHIP OF YPSILANTI (Subrecipient)
-Ypsilanti Township Community Center

By: _____
Brett D. Lenart (DATE)
(OCED Interim Director)

APPROVED AS TO FORM:

By: _____
Curtis N. Hedger (DATE)
Office of Corporation Counsel

BY: Brenda Stumbo 10-7-15
Brenda Stumbo (DATE)
(Charter Twp. of Ypsilanti Supervisor)

Karen Lovejoy Roe 10-7-15
Karen Lovejoy Roe

STANDARD ASSURANCES - NON-CONSTRUCTION PROGRAMS

Note: Certain of these assurances may not be applicable to your project or program. If you have questions, please contact the awarding agency. Further, certain Federal awarding agencies may require applicants to certify to additional assurances. If such is the case, you will be notified.

As the duly authorized representative of the applicant, I certify that the applicant:

1. Has the legal authority to apply for Federal assistance and the institutional, managerial and financial capability (including funds sufficient to pay the non-Federal share of project cost) to ensure proper planning, management and completion of the project described in this application.
2. Will give the awarding agency, the Comptroller General of the United States and, if appropriate, the State, through any authorized representative, access to and the right to examine all records, books, papers, or documents related to the award; and will establish a proper accounting system in accordance with generally accepted accounting standards or agency directives.
3. Will establish safeguards to prohibit employees from using their positions for a purpose that constitutes or presents the appearance of personal or organizational conflict of interest, or personal gain.
4. Will initiate and complete the work within the applicable time frame after receipt of approval of the awarding agency.
5. Will comply with the Intergovernmental Personnel Act of 1970 (42 U.S.C. §§4728-4763) relating to prescribed standards for merit systems for programs funded under one of the 19 statutes or regulations specified in Appendix A of OPM's Standards for a Merit System of Personnel Administration (5 C.F.R. 900, Subpart F).
6. Will comply with all Federal statutes relating to nondiscrimination. These include but are not limited to: (a) Title VI of the Civil Rights Act of 1964 (P.L. 88-352) which prohibits discrimination on the basis of race, color or national origin; (b) Title IX of the Education Amendments of 1972, as amended (20 U.S.C. §§1681-1683, and 1685-1686), which prohibits discrimination on the basis of sex; (c) Section 504 of the Rehabilitation Act of 1973, as amended (29 U.S.C. §794), which prohibits discrimination on the basis of handicaps; (d) the Age Discrimination Act of 1975, as amended (42 U.S.C. §§6101-6107), which prohibits discrimination on the basis of age; (e) the Drug Abuse Office and Treatment Act of 1972 (P.L. 92-255), as amended, relating to nondiscrimination on the basis of drug abuse; (f) the Comprehensive Alcohol Abuse and Alcoholism Prevention, Treatment and Rehabilitation Act of 1970 (P.L. 91-616), as amended, relating to nondiscrimination on the basis of alcohol abuse or alcoholism; (g) §§523 and 527 of the Public Health Service Act of 1912 (42 U.S.C. §§290 dd-3 and 290 ee 3), as amended, relating to confidentiality of alcohol and drug abuse patient records; (h) Title VIII of the Civil Rights Act of 1968 (42 U.S.C. §§3601 et seq.), as amended, relating to nondiscrimination in the sale, rental or financing of housing; (i) any other nondiscrimination provisions in the specific statute(s) under which application for Federal assistance is being made; and, (j) the requirements of any other nondiscrimination statute(s) which may apply to the application.
7. Will comply, or has already complied, with the requirements of Titles II and III of the Uniform Relocation Assistance and Real Property Acquisition Policies Act of 1970 (P.L. 91-646) which provide for fair and equitable treatment of persons displaced or whose property is acquired as a result of Federal or federally-assisted programs. These requirements apply to all interests in real property acquired for project purposes regardless of Federal participation in purchases.
8. Will comply, as applicable, with provisions of the Hatch Act (5 U.S.C. §§1501-1508 and 7324-7328) which limit the political activities of employees whose principal employment activities are funded in whole or in part with Federal funds.
9. Will comply, as applicable, with the provisions of the Davis-Bacon Act (40 U.S.C. §§276a-276a-7), the Copeland Act (40 U.S.C. §276c and 18 U.S.C. §874), and the Contract Work Hours and Safety Standards Act (40 U.S.C. §§327-333), regarding labor standards for federally-assisted construction sub-agreements.

10. Will comply, if applicable, with flood insurance purchase requirements of Section 102(a) of the Flood Disaster Protection Act of 1973 (P.L. 93-234) which requires recipients in a special flood hazard area to participate in the program and to purchase flood insurance if the total cost of insurable construction and acquisition is \$10,000 or more.
11. Will comply with environmental standards which may be prescribed pursuant to the following: (a) institution of environmental quality control measures under the National Environmental Policy Act of 1969 (P.L. 91-190) and Executive Order (EO) 11514; (b) notification of violating facilities pursuant to EO 11738; (c) protection of wetlands pursuant to EO 11990; (d) evaluation of flood hazards in floodplains in accordance with EO 11988; (e) assurance of project consistency with the approved State management program developed under the Coastal Zone Management Act of 1972 (16 U.S.C. §§1451 et seq.); (f) conformity of Federal actions to State (Clean Air) Implementation Plans under Section 176(c) of the Clean Air Act of 1955, as amended (42 U.S.C. §§7401 et seq.); (g) protection of underground sources of drinking water under the Safe Drinking Water Act of 1974, as amended (P.L. 93-523); and, (h) protection of endangered species under the Endangered Species Act of 1973, as amended (P.L. 93-205).
12. Will comply with the Wild and Scenic Rivers Act of 1968 (16 U.S.C. §§1271 et seq.) related to protecting components or potential components of the national wild and scenic rivers system.
13. Will assist the awarding agency in assuring compliance with Section 106 of the National Historic Preservation Act of 1966, as amended (16 U.S.C. §470), EO 11593 (identification and protection of historic properties), and the Archaeological and Historic Preservation Act of 1974 (16 U.S.C. §§469a-1 et seq.).
14. Will comply with P.L. 93-348 regarding the protection of human subjects involved in research, development, and related activities supported by this award of assistance.
15. Will comply with the Laboratory Animal Welfare Act of 1966 (P.L. 89-544, as amended, 7 U.S.C. §§2131 et seq.) pertaining to the care, handling, and treatment of warm blooded animals held for research, teaching, or other activities supported by this award of assistance.
16. Will comply with the Lead-Based Paint Poisoning Prevention Act (42 U.S.C. §§4801 et seq.) which prohibits the use of lead-based paint in construction or rehabilitation of residence structures.
17. Will cause to be performed the required financial and compliance audits in accordance with the Uniform Administrative Requirements, Cost Principles, and Audit Requirements for Federal Awards (2 CFR Chapter 1, and Chapter II, Parts 200, 215, 220, 225, 230) issued December 26, 2013 by the Executive Office of the President, Office of Management and Budget.
18. Will comply with all applicable requirements of all other Federal laws, executive orders regulations, and policies governing this program.
19. Will comply with the requirements of Section 106(g) of the Trafficking Victims Protection Act (TVPA) of 2000, as amended (22 U.S.C. 7104) which prohibits grant award recipients or a sub-recipient from (1) Engaging in severe forms of trafficking in persons during the period of time that the award is in effect (2) Procuring a commercial sex act during the period of time that the award is in effect or (3) Using forced labor in the performance of the award or subawards under the award.

Brenda L. Stumler
 Signature of Subrecipient's Authorized Representative
Charter Twp. of Ypsilanti
 Name of Subrecipient Organization

Supervisor
 Title of Subrecipient's Authorized Representative
clerk
10-7-15
 Date Submitted

ATTACHMENT B

CERTIFICATIONS REGARDING LOBBYING; DEBARMENT, SUSPENSION AND OTHER RESPONSIBILITY MATTERS; AND DRUG-FREE WORKPLACE REQUIREMENTS

Applicants should refer to the regulations cited below to determine the certification to which they are required to attest. Applicants should also review the instructions for certification included in the regulations before completing this form. Signature of this form provides for compliance with certification requirements under 34 CFR Part 82, "New Restrictions on Lobbying," and 34 CFR Part 85, "Government-wide Debarment and Suspension (Non-procurement) and Government-wide Requirements for Drug-Free Workplace (Grants)." The certifications shall be treated as a material representation of fact upon which reliance will be placed when Washtenaw County determines to award the covered transaction, grant, or cooperative agreement.

1. LOBBYING

As required by Section 1352, Title 31 of the U.S. Code, and implemented at 34 CFR Part 82, for persons entering into a grant or cooperative agreement over \$100,000, as defined at 34 CFR Part 82, Sections 82.105 and 82.110, the applicant certifies that:

(a) No Federal appropriated funds have been paid or will be paid, by or on behalf of the undersigned, to any person for influencing or attempting to influence an officer or employee of any agency, a Member of Congress, an officer or employee of Congress, or an employee of a Member of Congress in connection with the making of any Federal grant, the entering into of any cooperative agreement, and the extension, continuation, renewal, amendment, or modification of any Federal grant or cooperative agreement;

(b) If any funds other than Federal appropriated funds have been paid or will be paid to any person for influencing or attempting to influence an officer or employee of any agency, a Member of Congress, an officer or employee of Congress, or an employee of a Member of Congress in connection with this Federal grant or cooperative agreement, the undersigned shall complete and submit Standard Form - LLL, "Disclosure Form to Report Lobbying," in accordance with its instructions;

(c) The undersigned shall require that the language of this certification be included in the award documents for all subawards at all tiers (including subgrants, contracts under grants and cooperative agreements, and subcontracts) and that all subrecipients shall certify and disclose accordingly.

2. DEBARMENT, SUSPENSION, AND OTHER RESPONSIBILITY MATTERS

As required by Executive Order 12549, Debarment and Suspension, and implemented at 34 CFR Part 85, for prospective participants in primary covered transactions, as defined at 34 CFR Part 85, Sections 85.105 and 85.110—

A. The applicant certifies that it and its principals:

(a) Are not presently debarred, suspended, proposed for debarment, declared ineligible, or voluntarily excluded from covered transactions by any Federal department or agency;

(b) Have not within a three-year period preceding this application been convicted of or had a civil judgment rendered against them for commission of fraud or a criminal offense in connection with obtaining, attempting to obtain, or performing a public (Federal, State, or local) transaction or contract under a public transaction; violation of Federal or State antitrust statutes or commission of embezzlement, theft, forgery, bribery, falsification or destruction of records, making false statements, or receiving stolen property;

(c) Are not presently indicted for or otherwise criminally or civilly charged by a governmental entity (Federal, State, or local) with commission of any of the offenses enumerated in paragraph (2)(b) of this certification; and

(d) Have not within a three-year period preceding this application had one or more public transaction (Federal, State, or local) terminated for cause or default; and

B. Where the applicant is unable to certify to any of the statements in this certification, he or she shall attach an explanation to this application.

3. DRUG-FREE WORKPLACE (GRANTEES OTHER THAN INDIVIDUALS)

As required by the Drug-Free Workplace Act of 1988, and implemented at 34 CFR Part 85, Subpart F, for grantees, as defined at 34 CFR Part 85, Sections 85.605 and 85.610 –

A. The applicant certifies that it will or will continue to provide a drug-free workplace by:

(a) Publishing a statement notifying employees that the unlawful manufacture, distribution, dispensing, possession, or use of a controlled substance is prohibited in the grantee's workplace and specifying the actions that will be taken against employees for violation of such prohibition;

(b) Establishing an on-going drug-free awareness program to inform employees about:

- (1) The dangers of drug abuse in the workplace;
- (2) The grantee's policy of maintaining a drug-free workplace;
- (3) Any available drug counseling, rehabilitation, and employee assistance programs; and
- (4) The penalties that may be imposed upon employees for drug abuse violations occurring in the workplace;

(c) Making it a requirement that each employee to be engaged in the performance of the grant be given a copy of the statement required by paragraph (a);

(d) Notifying the employee in the statement required by paragraph (a) that, as a condition of employment under the grant, the employee will:

- (1) Abide by the terms of the statement; and
- (2) Notify the employer in writing of his or her conviction for a violation of a criminal drug statute occurring in the workplace no later than five calendar days after such conviction; (e) Notifying the agency, in writing, within 10 calendar days after receiving notice under subparagraph (d)(2) from an employee or otherwise receiving actual notice of such conviction. Employers of convicted employees must provide notice, including position title, to: Washtenaw County Administrator's Office, 220 N. Main, P.O. Box 8645, Ann Arbor, MI 48107-8645. Notice shall include the identification number(s) of each affected grant;

(f) Taking one of the following actions, within 30 calendar days of receiving notice under subparagraph (d)(2), with respect to any employee who is so convicted:

- (1) Taking appropriate personnel action against such an employee, up to and including termination, consistent with the requirements of the Rehabilitation Act of 1973, as amended; or (2) Requiring such employee to participate satisfactorily in a drug abuse assistance or rehabilitation program approved for such purposes by a Federal, State, or local health, law enforcement, or other appropriate agency;

(g) Making a good faith effort to continue to maintain a drug-free workplace through implementation of paragraphs (a), (b), (c), (d), (e), and (f).

B. The grantee may insert in the space provided below the site(s) for the performance of work done in connection with the specific grant:

Place of Performance (Street address, city, county, state, zip code)

Check [] if there are workplaces on file that are not identified here.

**DRUG-FREE WORKPLACE
(GRANTEES WHO ARE INDIVIDUALS)**

As required by the Drug-Free Workplace Act of 1988, and implemented at 34 CFR Part 85, Subpart F, for grantees, as defined at 34 CFR Part 85, Sections 85.605 and 85.610-

A. As a condition of the grant, I certify that I will not engage in the unlawful manufacture, distribution, dispensing, possession, or use of a controlled substance in conducting any activity with the grant; and

B. If convicted of a criminal drug offense resulting from a violation occurring during the conduct of any grant activity, I will report the conviction, in writing, within 10 calendar days of the conviction, to: Washtenaw County Administrator's Office, 220 N. Main, P.O. Box 8645, Ann Arbor, MI 48107-8645. Notice shall include the identification number(s) of each affected grant.

As the duly authorized representative of the applicant, I hereby certify that the applicant will comply with the above certifications.

Charter Twp. of Ypsilanti
Name of Subrecipient Organization

Brenda Stumbo, Supervisor/Karen Lovejoy Roe, Clerk
Printed Name and Title of Subrecipient's Authorized Representative

Brenda Stumbo
Signature of Subrecipient's Authorized Representative

10-7-15

_____ Date

Subrecipient Audit Certification

Federal Audit Requirements - Fiscal Years Beginning After December 26, 2014

Non-federal organizations which expend \$750,000 or more in federal funds during their fiscal year are required to have a Single Audit performed in accordance with the Uniform Administrative Requirements, Cost Principles, and Audit Requirements for Federal Awards (2 CFR Chapter I, and Chapter II, Parts 200, 215, 220, 225, 230) issued December 26, 2013 by the Executive Office of the President, Office of Management and Budget. Subrecipients must submit their audit report to the Federal Audit Clearinghouse within the earlier of 30 days after receipt of the auditor's report, or within 9 months after the end of the audit period for each year the Subrecipient meets the \$750,000 federal expenditure threshold.

Program: _____ CFDA Number: _____

Subrecipient Information:

Organization Name: _____

Street Address: _____

City, State, Zip Code: _____

Independent Audit Firm: _____

Certification for Fiscal Year Ending (mm/dd/yyyy): _____

(Check appropriate box):

I certify that the Subrecipient shown above **does not expect** to expend \$750,000 or more in federal funds during at least one fiscal year that funds are received for the above listed program and thus it will not be required to have a Single Audit performed under the Uniform Administrative Requirements, Cost Principles, and Audit Requirements for Federal Awards (2 CFR Chapter I, and Chapter II, Parts 200, 215, 220, 225, 230) issued December 26, 2013 by the Executive Office of the President, Office of Management and Budget, for the above listed program.

I certify that the Subrecipient shown above **expects it will** expend \$750,000 or more in federal funds during at least one fiscal year that funds are received for the above listed program and thus it will be required to have a Single Audit performed under the Uniform Administrative Requirements, Cost Principles, and Audit Requirements for Federal Awards (2 CFR Chapter I, and Chapter II, Parts 200, 215, 220, 225, 230) issued December 26, 2013 by the Executive Office of the President, Office of Management and Budget.

Doreen S. Stenmark *A. K. Gupta* 10-7-15
Signature of Subrecipient's Authorized Representative Date

For Washtenaw County Use Only

Reviewed By: _____ Date: _____

Attachment D:
Scope of Services

Congregate Meals Program

I. Participants

Eligibility Criteria

The Senior Nutrition Program will serve individuals that meet the following criteria:

- a. The eligible person must be 60 years of age or older, or be the spouse or partner of a person 60 years of age or older.
- b. Individuals living with disabilities who have not attained 60 years of age but who reside in housing facilities occupied primarily by older adults at which congregate nutrition services are provided, may receive such services.
- c. Non-older adult individuals living with disabilities who reside in a non-institutional household may accompany an eligible older individual and may participate on the same basis as the elderly participants.

Participant Registration and Recordkeeping

Upon registration, the participant should be provided the Participant Welcome Packet developed by OCED. Each participant must complete a registration form for the program. This form is submitted to OCED as soon as possible for entry into the database. Participants must sign on the Daily Sign-in Sheet prior to receiving each meal. Daily Sign-in Sheets must be submitted to OCED each month.

Participant Donations

Individuals who meet the above criteria will be encouraged to donate \$3.00 per meal, although no one will be turned away for inability to pay.

Individuals not otherwise eligible may be served if meals are available, and they must pay \$5.50 and receive a receipt for their payment. Meals for these individuals may only be provided after all eligible participants have been served.

Donations must be counted and signed for by two people and kept in a locked container until deposited into a bank account. At the end of each month, sites must mail to OCED the original deposit receipts and documentation showing that each day's donations were counted and signed for by two individuals. Donations will be invested back into the Senior Nutrition Program by OCED. Donation Summary sheets and donation deposit receipts must be submitted to OCED each month.

Referrals

Each congregate nutrition provider shall be able to provide information about the nearest home delivered meals program and be prepared to make referrals for persons who may be eligible for a home delivered meals program.

OCED will connect each site to food assistance program information, as well as services that exist locally, including other AAA 1-B partners. Each site shall take steps to inform participants about local, state, and federal food assistance programs and provide information and referral to assist the individual with obtaining benefits. Sites will also refer participants to other services, as needed.

Participant Complaints

Sites will handle initial participant complaints. Should a complaint be unable to be resolved, the complaint must be addressed in accordance with the Senior Nutrition Program Grievance Procedure.

Postings

Each program shall display, at a prominent location in each meal site, the AAA 1-B or the Office of Services to the Aging (OSA) Community Nutrition Services poster. A site may use its own poster as long as all required information is included and clearly presented. The poster shall contain the following information for each program; additional information pertaining to the program shall not be displayed so as to cause any misunderstanding or confusion with information presented on the poster:

- The name of the nutrition project director
- The nutrition project director's telephone number
- The suggested donation for eligible participants
- The guest fee to be charged non-eligible participants
- A statement of non-discrimination identical to the language on the OSA poster: No persons shall be excluded from participating in, denied the benefits of, or be subjected to discrimination under the program because of age, race, color, national origin, or handicap. If you believe you have been discriminated against, please contact the Affirmative Action Officer at the Michigan office of Services to the Aging, 517-373-2057 or the Chicago Regional Office of Civil Rights, 312-886-2359.

II. Facilities and Safety

Accessible site

Senior Nutrition Program sites must be operated within an accessible facility. Accessibility is defined as a participant living with a disability being able to enter the facility, use the rest room, and receive service that is at least equal in quality to that received by a participant not living with a disability. Documentation from a local building official or licensed architect is preferred.

Site Access, Maintenance, Security

Sites are responsible for

- Care and maintenance of the facility, including restrooms, equipment, kitchen, storage areas and areas of common use
- Snow removal
- Utility payments
- Arranging fire safety inspections; all reports must be forwarded to OCED
- Licensing by the Public Health Department
- Insurance coverage
- Security procedures

Fire safety standards

Each meal site must be inspected, by a local fire official, no less frequently than every three years. For circumstances where a local fire official is unavailable after a formal (written) request, OCED may conduct fire safety assessments of the Senior Nutrition Program site. Each meal site must conduct an annual fire drill. At a minimum, documentation of a fire drill must include the date of the fire drill and a signature verifying that the fire drill occurred. Best practices suggest that documentation should also include items such as number of minutes to evacuate, aspects that went well, and aspects that require improvement.

Michigan Food Code

Sites must comply with Michigan Food Code and local public health codes regulating food service establishments. Each meal site and kitchen operated by a congregate meal provider shall be licensed, as appropriate, by the local health department. The local health department is responsible for periodic inspections and for determining when a facility is to be closed for failure to meet Michigan Food Code standards. The site shall submit copies of inspection reports electronically to OCED within five days of receipt for all facilities in which the Senior Nutrition Program is conducted. It is the responsibility of the Senior Nutrition Program site to address noted violations promptly.

Site staff is responsible for measuring the temperature of food items upon arrival and immediately prior to service. Hot food must be maintained above 135 degrees. Should the temperature fall below 135 degrees, the food must be reheated to above 165 degrees prior to service. Cold foods should stay below 41 degrees. Measured temperatures must be recorded daily on the temperature chart to be submitted to OCED each month.

Site Closure

When a meal site is to be permanently or temporarily closed, the program will notify OCED in writing, including the following information:

1. Intent to close a site, as soon as possible.
2. A rationale for site closure (e.g. lack of attendance, inability to meet minimum standards and/or other requirements, loss of resources)

All closures must be approved by OCED. If a closure occurs without approval, funding may be withheld and/or recaptured at OCED's discretion.

Emergency Preparedness

In cases of inclement weather, sites should close their program when the school district in the area is closed. Closure must immediately be reported to OCED.

Procedures to be followed in the event of a medical emergency must be posted. Staff and volunteers will be trained by OCED during in-services on procedures to be followed in the event of a medical emergency.

III. Staffing

Staff

OCED will provide training in identified competency areas twice per year at Senior Nutrition Program in-services. Each site must designate a "Site Coordinator" to serve as point person for OCED. Site coordinators are expected to train staff members on an ongoing basis and manage all staff members in order to carry out expected duties. Training provided by site staff members should include, at a minimum, day-to-day operations, food safety basics, and Senior Nutrition Program policies and procedures. Site staff member are expected to utilize the Volunteer Training Manual provided by OCED to cover all necessary training areas.

Volunteers

Sites are responsible for volunteer recruitment, orientation, ongoing training, and management for day-to-day activities. Sites are expected to use the Volunteer Training Manual provided by OCED. Volunteers must submit a volunteer registration form. Volunteer time must be documented to be included as an in-kind contribution to the Senior Nutrition Program using the In-Kind Documentation Form. Forms must be submitted monthly to OCED.

In-service Training

Staff and volunteers of each program shall receive in-service training at least twice each fiscal year which is specifically designed to increase their knowledge and understanding of the program and to improve their skills at tasks performed in the provision of service.

IV. Meals

Assistive Eating Devices

Each site shall make available, store and clean, upon request, food containers and utensils used as assistive devices for participants who are living with disabilities as part of a therapeutic program.

Non-Approved Meals

Funding provided by OCED may not be used to contribute towards potluck dining activities.

Food Taken Out of Meal Site

Sites may allow leftovers (food served to participants and not eaten) to be taken out of the site if the following conditions are met:

- a. A sign shall be posted near the congregate meal sign informing the meal participants that all food removed from the site becomes the responsibility of the individual.
- b. All new congregate participants receive written material about food safety and preventing food-borne illness when they sign up.
- c. All participants receive written material about food safety and preventing food-borne illness annually.
- d. The individual is required to sign a waiver statement that has been added to the registration form that states that they are responsible for food taken out of the site.
- e. Containers are not provided for the leftovers.

If a regular congregate meal participant is unable to come to the site due to illness, the meal may be taken out of the site to the individual for no more than seven (7) days. If needed for more than seven days, the participant should be evaluated for home delivered meals. If the person taking out the meal is also a regular congregate participant, they may also take their meal out.

OCED will provide technical assistance and materials for carrying out this policy if necessary.

Nutrition Education

OCED will provide nutrition education materials to be distributed each month to participants. Additionally, OCED will arrange for any additional nutrition education sessions and coordinate with the site to deliver the nutrition education. Sites are welcome to arrange for additional nutrition education activities.

Exhibit A to Master Agreement

Purchase Agreement

This Purchase Agreement (this "Agreement") is dated as of September 30, 2015 between The Detroit Edison Company ("Company") and Charter Township of Ypsilanti ("Customer").

This Agreement is a "Purchase Agreement" as referenced in the Master Agreement for Municipal Street Lighting dated March 28, 2013 (the "Master Agreement") between Company and Customer. All of the terms of the Master Agreement are incorporated herein by reference. In the event of an inconsistency between this Agreement and the Master Agreement, the terms of this Agreement shall control.

Customer requests the Company to furnish, install, operate and maintain street lighting equipment as set forth below:

1. DTE Work Order Number:	43760394	
	If this is a conversion or replacement, indicate the Work Order Number for current installed equipment: N/A	
2. Location where Equipment will be installed:	Westbound intersection of Michigan Ave (US-12) & Dorset Ave in Ypsilanti Township, as more fully described on the map attached hereto as <u>Attachment 1</u> .	
3. Total number of lights to be installed:	1	
4. Description of Equipment to be installed (the " <u>Equipment</u> "):	Install 1 overhead fed black 135 watt Autobahn LED mounted on a 17'-6" Code 48 arm on an existing wood pole.	
5. Estimated Total Annual Lamp Charges	\$179.90	
6. Computation of Contribution in aid of Construction (" <u>CIAC Amount</u> ")	Total estimated construction cost, including labor, materials, and overhead:	\$1,197.98
	Credit for 3 years of lamp charges:	\$539.70
	CIAC Amount (cost minus revenue)	\$658.28
7. Payment of CIAC Amount:	Due promptly upon execution of this Agreement	
8. Term of Agreement	5 years. Upon expiration of the initial term, this Agreement shall continue on a month-to-month basis until terminated by mutual written consent of the parties or by either party with thirty (30) days prior written notice to the other party.	
9. Does the requested Customer lighting design meet IESNA recommended practices?	(Check One) <input type="checkbox"/> YES <input checked="" type="checkbox"/> NO If "No", Customer must sign below and acknowledge that the lighting design does not meet IESNA recommended practices Signature: <i>Brenda L. Stumbo</i> <i>Karen Lovejoy Roe</i> Brenda L. Stumbo Karen Lovejoy Roe	
10. Customer Address for Notices:	Charter Township of Ypsilanti 7200 S Huron River Dr Ypsilanti, MI 48197 Attn: Karen Lovejoy Roe	

11. Special Order Material Terms:

All or a portion of the Equipment consists of special order material: (check one) YES NO

If "Yes" is checked, Customer and Company agree to the following additional terms.

A. Customer acknowledges that all or a portion of the Equipment is special order materials ("SOM") and not Company's standard stock. Customer will purchase and stock replacement SOM and spare parts. When replacement equipment or spare parts are installed from Customer's inventory, the Company will credit Customer in the amount of the then current material cost of Company standard street lighting equipment.

B. Customer will maintain an initial inventory of at least N/A posts and N/A luminaires and any other materials agreed to by Company and Customer, and will replenish the stock as the same are drawn from inventory. Costs of initial inventory are included in this Agreement. The Customer agrees to work with the Company to adjust inventory levels from time to time to correspond to actual replacement material needs. If Customer fails to maintain the required inventory, Company, after 30 days' notice to Customer, may (but is not required to) order replacement SOM and Customer will reimburse Company for such costs. Customer's acknowledges that failure to maintain required inventory could result in extended outages due to SOM lead times.

C. The inventory will be stored at _____.
Access to the Customers inventory site must be provided between the hours of 9:00 am to 4:00 pm, Monday through Friday with the exceptions of federal Holidays. Customer shall name an authorized representative to contact regarding inventory: levels, access, usage, transactions, and provide the following contact information to the Company:

Name: _____ Title: _____

Phone Number: _____ Email: _____

The Customer will notify the Company of any changes in the Authorized Customer Representative. The Customer must comply with SOM manufacturer's recommended inventory storage guidelines and practices. Damaged SOM will not be installed by the Company.

D. In the event that SOM is damaged by a third party, the Company may (but is not required to) pursue a damage claim against such third party for collection of all labor and stock replacement value associated with the damage claim. Company will promptly notify Customer as to whether Company will pursue such claim.

E. In the event that SOM becomes obsolete or no longer manufactured, the Customer will be allowed to select new alternate SOM that is compatible with the Company's existing infrastructure.

F. Should the Customer experience excessive LED equipment failures, not supported by LED manufacturer warranties, the Company will replace the LED equipment with other Company supported Solid State or High Intensity Discharge luminaires at the Company's discretion. The full cost to complete these replacements to standard street lighting equipment will be the responsibility of the Customer.

12. Experimental Emerging Lighting Technology ("EELT") Terms:

All or a portion of the Equipment consists of EELT: (check one) YES NO

If "Yes" is checked, Customer and Company agree to the following additional terms.

A. The annual billing lamp charges for the EELT equipment has been calculated by the Company are based upon the estimated energy and maintenance cost expected with the Customer's specific pilot project EELT equipment.

B. Upon the approval of any future MPSC Option I tariff for EELT street lighting equipment, the approved rate schedules will automatically apply for service continuation to the Customer under Option 1 Municipal Street Lighting Rate, as approved by the MPSC. The terms of this paragraph B replace in its entirety Section 7 of the Master Agreement with respect to any EELT equipment purchased under this Agreement.

Company and Customer have executed this Purchase Agreement as of the date first written above.

Company:

The Detroit Edison Company

By: _____

Name: _____

Title: _____

Customer:

Charter Township of Ypsilanti

By: Brenda L. Stumbo | Karen Lovejoy Roe

Name: Brenda L. Stumbo | Karen Lovejoy Roe

Title: Supervisor | Clerk

10-7-15

10-7-15

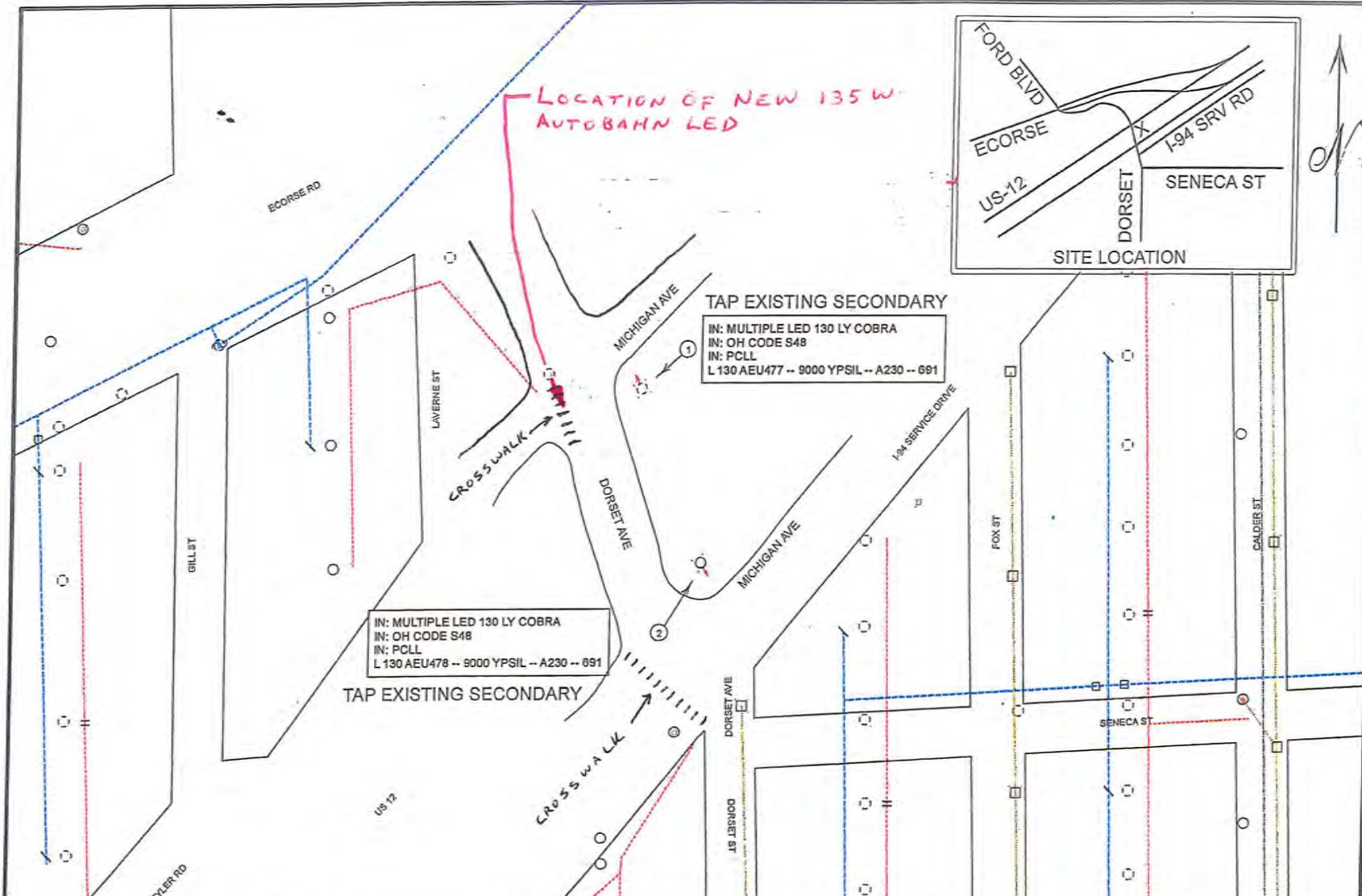

TAP EXISTING SECONDARY
 IN: MULTIPLE LED 130 LY COBRA
 IN: OH CODE S48
 IN: PCLL
 L 130 AEU477 -- 9000 YPSIL -- A230 -- 691

TAP EXISTING SECONDARY
 IN: MULTIPLE LED 130 LY COBRA
 IN: OH CODE S48
 IN: PCLL
 L 130 AEU478 -- 9000 YPSIL -- A230 -- 691

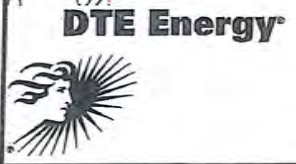

Work Order # 42872982		Work Order Description NBUS - 2 OH - MICHIGAN (US-12) & DORSET - YPSILANTI TWP		GIS-DSN 42872983	SRW	RSD	PH	PLC
Service Center ANN		Circuit #1 EMRCK2922	Circuit #2	GOH 42872992	COS	CUG	CUL	CUS
Worksite City Ypsilanti township, Washtenaw County			Worksite Twp.	Worksite County				SCMAT 42872991
Town	Range	Section	Qtr	Planner Name Shaw, Richard H	CUE Request # 531558	Version 1	Plot Date 7/20/2015	Scale NONE
		03S07E11						

Supervisor
BRENDA L. STUMBO
Clerk
KAREN LOVEJOY ROE
Treasurer
LARRY J. DOE
Trustees
JEAN HALL CURRIE
STAN ELDRIDGE
MIKE MARTIN
SCOTT MARTIN



**Accounting
Department**

7200 S. Huron River Drive
Ypsilanti, MI 48197
Phone: (734) 484-3702
Fax: (734) 484-5154

Charter Township of Ypsilanti

STATEMENTS AND CHECKS

OCTOBER 20, 2015 BOARD MEETING

ACCOUNTS PAYABLE CHECKS -	\$ 855,045.62
HAND CHECKS -	<u>\$ 216,995.77</u>
GRAND TOTAL -	\$ 1,072,041.39

Choice Health Care Deductible – SEPTEMBER 2015

ACH EFT -	\$31,422.88
ADMIN FEE -	\$ 1,177.50 (AUG)

Check Date	Bank	Check	Vendor	Vendor Name	Amount
<i>Hand Checks</i>					
Bank AP AP					
09/30/2015	AP	169943	6821	AT & T	24.18
09/30/2015	AP	169944	6821	AT & T	80.74
09/30/2015	AP	169945	5049	BLUE CROSS BLUE SHIELD OF MI	130,321.29
09/30/2015	AP	169946	BCBS	BLUE CROSS BLUE SHIELD OF MI	33,417.29
09/30/2015	AP	169947	16509	CLEAR RATE COMMUNICATIONS, INC	1,089.56
09/30/2015	AP	169948	0363	COMCAST CABLE	214.90
09/30/2015	AP	169949	0363	COMCAST CABLE	92.85
09/30/2015	AP	169950	0363	COMCAST CABLE	156.06
09/30/2015	AP	169951	2002	DELTA DENTAL PLAN OF MICHIGAN	14,031.44
09/30/2015	AP	169952	0426	GUARDIAN ALARM	750.00
09/30/2015	AP	169953	0426	GUARDIAN ALARM	163.11
09/30/2015	AP	169954	0426	GUARDIAN ALARM	1,397.52
09/30/2015	AP	169955	6263	STANDARD INSURANCE COMPANY	4,288.43
09/30/2015	AP	169956	VSP	VISION SERVICE PLAN	2,488.32
09/30/2015	AP	169957	16404	WELLS FARGO FINANCIAL LEASING	5,503.85
09/30/2015	AP	169958	D. ROSE	DOUGLAS ROSE	55.50
09/30/2015	AP	169959	S. WADE	SUSAN WADE	14.00
10/05/2015	AP	169960	0118	DTE ENERGY	14,966.09
10/06/2015	AP	169961	HNV	HOME OF NEW VISION	2,121.00
10/06/2015	AP	169962	0480	YPSILANTI COMMUNITY	3,753.14
10/07/2015	AP	169963	A. KING	APRIL KING	14.00
10/07/2015	AP	169964	A. BOWLES	ARTHUR BOWLES	14.00
10/07/2015	AP	169965	13022	ASHLEY HAVERKATE	35.50
10/07/2015	AP	169966	B. EDDINS	BARBARA EDDINS	14.00
10/07/2015	AP	169967	B. HALL	BRIANA HALL	35.50
10/07/2015	AP	169968	CHOWARTH	CHARLOTTE HOWARTH	14.00
10/07/2015	AP	169969	C. BURDEN	CONSTANCE BURDEN	14.00
10/07/2015	AP	169970	C. KURAS	CRAIG KURAS	35.50
10/07/2015	AP	169971	E. PARSONS	ELIZABETH PARSONS	14.00
10/07/2015	AP	169972	E. SCHILDH	EMILY SCHILDHOUSE	35.50
10/07/2015	AP	169973	H. ABULIZZ	HEBA ADULIZZ	35.50
10/07/2015	AP	169974	J. CREPS	JANA CREPS	14.00
10/07/2015	AP	169975	J. AETHYR	JANELLE AETHYR	14.00
10/07/2015	AP	169976	J. POLLARD	JANEYA POLLARD	14.00
10/07/2015	AP	169977	J. FRIERSON	JENNIFER FRIERSON	14.00
10/07/2015	AP	169978	J. SCHMIDT	JULIE SCHMIDT	14.00
10/07/2015	AP	169979	L. SCOTT	LINDA SCOTT	14.00
10/07/2015	AP	169980	L. NICHOLS	LISA NICHOLS	14.00
10/07/2015	AP	169981	M. PATTEN	MARGARET PATTERSON	35.50
10/07/2015	AP	169982	M. GRECA	MARY GRECA-MOORE	14.00
10/07/2015	AP	169983	P. DREXLER	PATRICIA DREXLER-JONES	14.00
10/07/2015	AP	169984	P KING	PATRICIA KING	14.00
10/07/2015	AP	169985	P. JANSSEN	PAUL JANSSEN	14.00
10/07/2015	AP	169986	RECTOR	PHYLLIS RECTOR	14.00
10/07/2015	AP	169987	S. DIALLO	SAFIYAH DIALLO	14.00
10/07/2015	AP	169988	S. GOMEZ	SHANNON GOMEZ	14.00
10/07/2015	AP	169989	S. SON	STEVEN SON	14.00
10/07/2015	AP	169990	T. SAWYER	TRAVIS SAWYER	14.00
10/07/2015	AP	169991	W. FLOYD	WALTER FLOYD	14.00
10/07/2015	AP	169992	W. GRIFFIN	WALTER GRIFFIN	14.00
10/07/2015	AP	169993	W. WASHING	WANDA WASHINGTON-JONES	14.00
10/07/2015	AP	169994	W. MEREDIT	WILLIAM MEREDITH	35.50
10/07/2015	AP	169995	W. OSBORNE	WILLIAM OSBORNE	14.00
10/07/2015	AP	169996	Z. BRYANT	ZACHERY BRYANT	14.00
10/09/2015	AP	169997	DTE	DTE ENERGY MICHCON DEMOLITION	1,440.00 V
10/09/2015	AP	169998	DTE	DTE ENERGY MICHCON	1,440.00

AP TOTALS:

Total of 56 Checks:	218,435.77
Less 1 Void Checks:	1,440.00
Total of 55 Disbursements:	216,995.77

User: mharris

CHECK NUMBERS 169999 - 170114

DB: Ypsilanti-Twp

Check Date	Bank	Check	Vendor	Vendor Name	Amount
Bank AP AP					
10/20/2015	AP	169999	4ALL	4ALLPROMOS / K-READ	435.08
10/20/2015	AP	170000	2937	A & R TOTAL CONSTRUCTION, INC.	70.38
10/20/2015	AP	170001	0001	A.F. SMITH ELECTRIC	346.01
10/20/2015	AP	170002	15493	ADAM KURTINAITIS	1,120.00
10/20/2015	AP	170003	ALIENVAULT	ALIENVAULT INC	2,340.00
10/20/2015	AP	170004	0560	ALLGRAPHICS CORPORATION	1,855.65
10/20/2015	AP	170005	6981	ALLIED SUBSTANCE ABUSE	76.00
10/20/2015	AP	170006	A. FREY	ANDREW FREY	16.00
10/20/2015	AP	170007	0022	ANN ARBOR WELDING SUPPLY CO	198.09
10/20/2015	AP	170008	0215	AUTO VALUE YPSILANTI	87.57
10/20/2015	AP	170009	B. UDEH	BASIL UDEH	92.00
10/20/2015	AP	170010	BPB	BATTERIES PLUS BULBS	69.98
10/20/2015	AP	170011	0071	BRENDA STUMBO	126.90
10/20/2015	AP	170012	0898	BS & A SOFTWARE	17,340.00
10/20/2015	AP	170013	6959	BUTZEL LONG	693.00
10/20/2015	AP	170014	C. JUSTICE	CATHERINE JUSTICE	202.50
10/20/2015	AP	170015	3460	CDW GOVERNMENT INC	2,726.99
10/20/2015	AP	170016	CEDAR POIN	CEDAR POINT	623.00
10/20/2015	AP	170017	16151	CODE 42 SOFTWARE, INC.	432.00
10/20/2015	AP	170018	15452	COLD CUT KRUISE	54.30
10/20/2015	AP	170019	0582	CONGDON'S	258.90
10/20/2015	AP	170020	CONTI	CONTI	19,756.00
10/20/2015	AP	170021	16157	COOPER WEST	40.00
10/20/2015	AP	170022	6683	D & B POWER ASSOCIATES, INC.	1,063.00
10/20/2015	AP	170023	DAWN FARM	DAWN FARM	1,976.35
10/20/2015	AP	170024	16212	DELL MARKETING L.P.	16,758.30
10/20/2015	AP	170025	DLN	DETROIT LEGAL NEWS	189.00
10/20/2015	AP	170026	D OTROMPK	DEVIN OTROMPK	43.00
10/20/2015	AP	170027	DEX F&N	DEXTER F & N	340.19
10/20/2015	AP	170028	2039	DTE ENERGY COMPANY -	658.28
10/20/2015	AP	170029	DYNAMIC	DYNAMIC DRAINS LLC	37.50
10/20/2015	AP	170030	15987	EDGAR RAINEY	30.00
10/20/2015	AP	170031	2898	EMERGENT HEALTH PARTNERS	5,956.15
10/20/2015	AP	170032	15796	FIRST DUE FIRE SUPPLY	492.93
10/20/2015	AP	170033	0135	FORMS TRAC, ENTERPRISES	244.76
10/20/2015	AP	170034	15962	GLORIA MAYER	26.00
10/20/2015	AP	170035	1233	GORDON FOOD SERVICE INC.	777.28
10/20/2015	AP	170036	6161	GOVERNMENTAL CONSULTANT	2,850.00
10/20/2015	AP	170037	0107	GRAINGER	240.72
10/20/2015	AP	170038	G. MAYER	GRANT MAYER	26.00
10/20/2015	AP	170039	7135	HABITAT FOR HUMANITY	90,000.00
10/20/2015	AP	170040	6786	HERITAGE-CRYSTAL CLEAN, LLC	584.98
10/20/2015	AP	170041	0503	HOME DEPOT	345.63
10/20/2015	AP	170042	HNW	HOME OF NEW VISION	1,951.00
10/20/2015	AP	170043	6147	HP DIRECT	5,051.60
10/20/2015	AP	170044	6306	IAFC MEMBERSHIP	209.00
10/20/2015	AP	170045	15496	J.F. MOORE & ASSOCIATES, LLC	176.00
10/20/2015	AP	170046	J. ROSEMAN	JEFFREY ROSEMAN	25.00
10/20/2015	AP	170047	15972	JESSE HILDEBRANDT	33.00
10/20/2015	AP	170048	J. ROHAN	JESSICA ROHAN	101.25
10/20/2015	AP	170049	5731	JOSEPH LAWSON	350.00
10/20/2015	AP	170050	JOSMITH	JOSEPH SMITH	13.00
10/20/2015	AP	170051	K. KUMPELI	KADEN KUMPELIS	30.00
10/20/2015	AP	170052	K. WHITE	KEVIN WHITE	30.00
10/20/2015	AP	170053	L. DOBBINS	LAYLA DOBBINS	9.00
10/20/2015	AP	170054	LCI	LEO'S CONEY ISLAND	75.00
10/20/2015	AP	170055	L. GODO	LISA GODO	266.00
10/20/2015	AP	170056	6550	LOOKING GOOD LAWNS	662.00
10/20/2015	AP	170057	6467	LOWE'S	352.14
10/20/2015	AP	170058	0158	MARK HAMILTON	1,500.00
10/20/2015	AP	170059	0253	MCLAIN AND WINTERS	99,449.58
10/20/2015	AP	170060	16445	MCMASTER-CARR	224.35
10/20/2015	AP	170061	6043	MEADOWBROOK, INC.	55.00
10/20/2015	AP	170062	SEMEYN.	MICHAEL SEMEYN	30.00
10/20/2015	AP	170063	16461	MICHIGAN LINEN SERVICE, INC.	1,253.52
10/20/2015	AP	170064	SEMEYN	MITCHEL SEMEYN	30.00
10/20/2015	AP	170065	0297	MUNICIPAL CODE CORPORATION	1,185.11
10/20/2015	AP	170066	2986	NAPA AUTO PARTS*	33.48
10/20/2015	AP	170067	NHTS	NATIONAL HOSE TESTING SPECIALTIES	840.00
10/20/2015	AP	170068	OCAA0	OCAA0	90.00
10/20/2015	AP	170069	2997	OFFICE EXPRESS	286.94
10/20/2015	AP	170070	0309	ORCHARD, HILTZ & MCCLIMENT INC	26,658.44
10/20/2015	AP	170071	0501	PARK ATHLETIC SUPPLY	112.00
10/20/2015	AP	170072	15971	PARKER ALLEN	33.00
10/20/2015	AP	170073	0913	PARKWAY SERVICES, INC.	120.00
10/20/2015	AP	170074	PEPSI	PEPSI BEVERAGES COMPANY	281.76
10/20/2015	AP	170075	P. POWER	PETER POWER	875.00
10/20/2015	AP	170076	0327	PINTER'S FLOWERLAND, INC.	43.07

Check Date	Bank	Check	Vendor	Vendor Name	Amount
10/20/2015	AP	170077	POWER PLUS	POWER PLUS ENGINEERING	315.00
10/20/2015	AP	170078	0722	PRINTING SYSTEMS	1,003.95
10/20/2015	AP	170079	15084	PROSOURCE TECHNOLOGIES	5,344.80
10/20/2015	AP	170080	R. FREY	RACHAEL FREY	16.00
10/20/2015	AP	170081	15420	RESERVE ACCOUNT	10,000.00
10/20/2015	AP	170082	6308	RKA PETROLEUM	5,099.52
10/20/2015	AP	170083	R. UDEH	ROBERA UDEH	16.00
10/20/2015	AP	170084	R. NOEL	ROBERT NOEL	92.00
10/20/2015	AP	170085	R. LEONE	ROCCO LEONE	26.00
10/20/2015	AP	170086	SAS	SAS COMMUNITY EDUCATION	1,374.00
10/20/2015	AP	170087	0383	SHERWIN WILLIAMS COMPANY	342.09
10/20/2015	AP	170088	15751	SOUTHERN COMPUTER WAREHOUSE	3,076.94
10/20/2015	AP	170089	1507	SPARTAN DISTRIBUTORS	377.31
10/20/2015	AP	170090	SPOK, INC	SPOK, INC.	460.68
10/20/2015	AP	170091	STANTEC	STANTEC	871.00
10/20/2015	AP	170092	15603	STATE BAR OF MICHIGAN	570.00
10/20/2015	AP	170093	0632	STERICYCLE INC	167.11
10/20/2015	AP	170094	16295	STERN BROTHERS & CO	712.50
10/20/2015	AP	170095	0449	SYSCO FOOD SERVICES OF DETROIT	123.00
10/20/2015	AP	170096	11025	TAMMIE KEEN	28.87
10/20/2015	AP	170097	1227	TARGET INFORMATION	110.96
10/20/2015	AP	170098	6974	TERRY CONDIT	162.00
10/20/2015	AP	170099	15941	TODD BARBER	4,050.00
10/20/2015	AP	170100	T. ERBY	TRAVIS ERBY	283.50
10/20/2015	AP	170101	T. ZYNGIER	TROY ZYNGIER	36.00
10/20/2015	AP	170102	4779	U.S. BANK, N.A.	35,040.00
10/20/2015	AP	170103	15175	ULLIANCE	946.95
10/20/2015	AP	170104	V. BASS	VALERIE BASS	101.25
10/20/2015	AP	170105	6627	VICTORY LANE	89.73
10/20/2015	AP	170106	16425	WASHTENAW COUNTY LEGAL NEWS	345.00
10/20/2015	AP	170107	15249	WASHTENAW COUNTY SHERIFF'S OFFICE	663.00
10/20/2015	AP	170108	0444	WASHTENAW COUNTY TREASURER#	14,959.46
10/20/2015	AP	170109	0444	WASHTENAW COUNTY TREASURER#	22.56
10/20/2015	AP	170110	0444	WASHTENAW COUNTY TREASURER#	452,541.25
10/20/2015	AP	170111	WASHTENAW	WASHTENAW URGENT CARE	100.00
10/20/2015	AP	170112	1662	WILLIS FEED MILL	132.00
10/20/2015	AP	170113	4263	WOLVERINE FREIGHTLINER	743.61
10/20/2015	AP	170114	0729	ZEP MANUFACTURING COMPANY	665.92

AP TOTALS:

Total of 116 Checks:	855,045.62
Less 0 Void Checks:	0.00
Total of 116 Disbursements:	<u>855,045.62</u>

OFFICE OF THE TREASURER
LARRY J. DOE



MONTHLY TREASURER'S REPORT
SEPTEMBER 1, 2015 THROUGH SEPTEMBER 30, 2015

Account Name	Beginning Balance	Cash Receipts	Cash Disbursements	Ending Balance
101 - General Fund	3,849,413.94	64,759.85	930,354.53	2,983,819.26
101 - Payroll	315,714.63	738,729.01	726,704.96	327,738.68
101 - Willow Run Escrow	142,258.70	23.38	0.00	142,282.08
206 - Fire Department	1,635,640.66	2,761.89	249,904.31	1,388,498.24
208 - Parks Fund	5,651.72	0.04	205.50	5,446.26
212 - Roads/Bike Path/Rec/General Fund	154,027.74	1,058.04	76,197.92	78,887.86
225 - Environmental Clean-up	444,413.42	3.41	0.00	444,416.83
226 - Environmental Services	2,668,940.99	963.96	184,734.14	2,485,170.81
230 - Recreation	239,293.35	133,209.10	168,375.48	204,126.97
236 - 14-B District Court	25,917.33	121,824.25	89,989.13	57,752.45
244 - Economic Development	67,191.59	0.52	0.00	67,192.11
248 - Rental Inspections	174,625.98	13,811.35	14,003.15	174,434.18
249 - Building Department Fund	502,814.51	53,595.88	38,397.94	518,012.45
250 - LDFA Tax	75,001.09	0.58	0.00	75,001.67
252 - Hydro Station Fund	520,476.18	98,061.79	56,073.81	562,464.16
266 - Law Enforcement Fund	3,799,665.05	21,969.89	73,767.33	3,747,867.61
280 - State Grants	18,387.05	0.14	0.00	18,387.19
301 - General Obligation	5,167.56	0.04	0.00	5,167.60
397 - Series "B" Cap. Cost of Funds	38,668.82	0.30	0.00	38,669.12
398 - LDFA 2006 Bonds	39,678.81	0.30	0.00	39,679.11
498 - Capital Improvement 2006 Bond Fund	337,064.85	55.41	0.00	337,120.26
584 - Green Oaks Golf Course	212,067.59	71,792.98	55,965.00	227,895.57
590 - Compost Site	883,632.59	27,404.46	21,025.20	890,011.85
595 - Motor Pool	237,459.33	1.78	9,343.59	228,117.52
701 - General Tax Collection	29,998.14	3,304.37	2,911.39	30,391.12
703 - Current Tax Collections	4,332,269.42	27,556,873.18	18,335,649.48	13,553,493.12
707 - Bonds & Escrow/GreenTop	790,451.21	5,258.31	20,966.75	774,742.77
708 - Fire Withholding Bonds	207,784.25	34.16	0.00	207,818.41
893 - Nuisance Abatement Fund	63,709.13	2,007.14	3,246.64	62,469.63
ABN AMRO Series "B" Debt Red. Cap.Int.	17,453.43	0.00	0.00	17,453.43
GRAND TOTAL	21,834,839.06	28,917,505.51	21,057,816.25	29,694,528.32

SUPERVISOR REPORT

- A. SUPERVISOR STUMBO WILL REPORT ON MEETINGS ATTENDED BY OFFICIALS AND STAFF

CLERK REPORT

OCTOBER 20, 2015

Submitted by Karen Lovejoy Roe, Clerk

- **POLLARD BANKNOTE RIBBON CUTTING MONDAY, SEPTEMBER 21, 2015-** Supervisor Stumbo, Clerk Lovejoy Roe and Treasurer Doe attended the Ribbon Cutting Ceremony at Pollard Banknote in celebration of a new \$20 million printing press. It was a grand event attended by many State of Michigan Lottery Commissioners and lottery related businesses along with Pollard Banknote employees. There were many out of state guests from lottery associated businesses and commissions also. Federal, state and local elected officials were also in attendance. The purchase and installation of the new printing press is the largest investment in the history of Pollard Banknote. It clearly demonstrates the long term commitment of Pollard Banknote to the Ypsilanti Township community.
- **DEVELOPING QUALIFICATIONS FOR REQUESTS FOR PROPOSALS FOR WORKFLOW AND DOCUMENT MANAGEMENT-**On Tuesday, September 22, 2015 representatives from the Office of Community Standards, Accounting, Clerk's, and the Information Systems Departments met to formalize the qualifications that Ypsilanti Township would require from a professional services consultant that would contract with the Township for leading the township in the management of documents and workflow processes. A timeline was agreed upon to move this project forward before the end of 2015.
- **VAN BUREN SCHOOLS ELECTION-NOVEMBER 3, 2015-**Van Buren Schools is having a bond renewal election on November 3, 2015. This election impacts the two Van Buren Schools precincts in Ypsilanti Township. Ypsilanti Township will be handling the election for these two precincts at Rawsonville School. The ballots are available and are being mailed out daily as residents request an Absentee Ballot.
- **WASHTENAW COUNTY MUNICIPAL CLERK'S ASSOCIATION-**Clerk Lovejoy Roe, Deputy Clerk Lisa Garrett and Elections Specialist Angela Robinson attended the Washtenaw County Municipal Clerk's Association meeting on Wednesday, September 23, 2015 at Superior Township Hall. Vendors made presentations on the proposed new election equipment that may be available before the 2016 Presidential Election cycle. The State of Michigan is currently reviewing the equipment proposals and a recommendation to the County Clerks across the state is expected by the first of 2016. It was explained that the State would allow some jurisdictions to pilot the new equipment in 2016. The new equipment appears to be very user friendly with many features to allow voting to take less time and more efficient calculations of results, with more safety features built in. The election equipment that was demonstrated is already being used in other states and countries around the world.

- **TOURISM AND ECONOMIC DEVELOPMENT IN THE YPSILANTI COMMUNITY-** Supervisor Stumbo and Clerk Lovejoy Roe attended a meeting at the Marriott Hotel on Tuesday, September 9, 2015 to participate in a presentation hosted by the Ypsilanti Visitors and Convention Bureau. This event featured a specialist sharing research and ideas that have been practiced to increase the number of tourists in a community. He also expanded on ways tourism can be a crucial part of the engine that drives economic development in your community.
- **WAYFINDING MEETING-**On Tuesday, October 13, 2015 Supervisor Stumbo and Clerk Lovejoy Roe attended a meeting with representatives from Washtenaw County and the Ypsilanti Area Visitors and Convention Bureau to discuss the plan for installing directional signs in Ypsilanti Township. This group has been working on this plan for coordinated signage in both the City and Township of Ypsilanti for over a year. The sign locations, type and designs have been agreed upon and now the group is seeking funding from many different agencies and groups to proceed. The Township Board will be asked to authorize financing for three signs to be placed in the township by the first part of 2016. This will be the first phase, there are many other signs to be placed in the township but the group is attempting to keep the costs for each phase at \$145,000 to be shared amongst a large group of institutions. The Township's portion will be around \$8,000 for the three signs.
- **REIMAGINE WASHTENAW-**Clerk Lovejoy Roe attended the Reimagine Washtenaw monthly meeting on Wednesday, October 14, 2015. Discussion included access management plan implementation, updates on mid-block crossings, CDBG funded sidewalk infill projects and the Arborland Super Stop. Ways to have MDOT adopt or support the Corridor Improvement Study was discussed along with community updates being provided. Joe Lawson is working on obtaining the easements for the CDBG funded portion of Ypsilanti Township sidewalk infill project on Washtenaw.

TREASURER REPORT

THERE IS NO WRITTEN TREASURER REPORT

TRUSTEE REPORT

THERE IS NO WRITTEN TRUSTEE REPORT

ATTORNEY REPORT

GENERAL LEGAL UPDATE

OLD BUSINESS

RESOLUTION 2015-41

Amending the Code of Ordinances, Chapter 30, Article II Entitled Fire Prevention Code by Adoption of the 2012 Edition of the International Fire Prevention Code

Whereas, the Charter Township of Ypsilanti Board of Trustees recognizes the need for a modern, up-to-date fire code addressing conditions hazardous to life and property from fire and explosion hazards; the storage, handling and use of hazardous substances and materials; and the use and occupancy of buildings and premises; and

Whereas, the International Fire Code, 2012 Edition, is designed to meet these needs through model code regulations that safeguard public health and safety; and

Whereas, the International Fire Code, 2012 Edition, is fully compatible with the Michigan Building Code, Michigan Residential Code, Michigan Rehabilitation Code and the 2012 International Property Maintenance Code.

Whereas, the Township Fire Department recommends adoption of Ordinance 2015-453.

Now Therefore,

Be it resolved, that the Charter Township of Ypsilanti Board of Trustees hereby adopts by reference attached Ordinance No. 2015-453 amending the Code of Ordinances of the Charter Township of Ypsilanti, Article II, Fire Prevention Code.

PROPOSED ORDINANCE NO. 2015-453

*An Ordinance Amending the Code of Ordinances,
Charter Township of Ypsilanti, Chapter 30, Article II
Entitled Fire Prevention Code by Adoption of the
2012 Edition of the International Fire Prevention Code*

The Charter Township of Ypsilanti hereby **Ordains** that Chapter 30 of the Code of Ordinances for Ypsilanti Township, Article II entitled Fire Prevention Code is hereby amended as follows:

DELETE in its entirety the current Article II entitled Fire Prevention Code (Sections 30-26 through 30-31, inclusive).

ADD the following new provision:

A. Adoption by Reference.

A certain document, copies of which are on file with the office of the Township Clerk and the Bureau of Fire Prevention, being marked and designated as the "**International Fire Code, 2012 Edition, International Code Council,**" is adopted by reference, including Appendix Chapters A through J, and all references therein printed – except those section and appendices herein amended, deleted or added. This document shall be known and may be cited as the "**Fire Prevention Code of the Charter Township of Ypsilanti,**" regulating and governing conditions hazardous to life and property from the standpoint of fire and explosion and for defining the scope of authority of the chief of the fire department and the bureau of fire prevention.

B. Purpose of Article.

The purpose of this article is to provide for the prevention of fires and the protection of persons and property from exposure to the dangers of fire and explosion; to authorize the investigation of fires and the discovery of crime or other offenses in relation thereto; to require the razing, repair and alterations of building, and the clearing and improvement of premises which constitute a fire hazard or a menace to the peace, security or safety of persons or property; to control the use and occupancies of such premises; to provide for the transportation, use and storage of inflammable liquids, compressed gases, and corrosive liquids; to prohibit the use of certain fire extinguishers and fire extinguishing agents; to provide for the administration of this article; and to fix penalties for violation of the provisions of this article.

C. Code Available for Public Use and Inspection.

Complete printed copies of the **Fire Prevention Code** of the Charter Township of Ypsilanti and supplements, therein adopted, are available for public use and inspection at the office of the Township Clerk and at the office of the Bureau of Fire Prevention.

D. References in Code.

References in the **Fire Prevention Code** of the Charter Township of Ypsilanti and supplements to the word "*state*" shall mean the State of Michigan; reference to the word "*municipality*"

shall mean the Township of Ypsilanti; references to the term “*corporation counsel*” shall be held to mean the attorney for the township; reference to the term “*bureau of fire prevention*” shall mean the township fire department; and reference to the term “*fire official*” shall be held to mean the chief of the fire department or his authorized designee.

E. Code Revisions.

The following sections of the International Fire Code, 2012 Edition, International Code Council, are hereby revised.

Section 101.1 - insert Charter Township of Ypsilanti

Section 109.3 – delete in its entirety and replace with the following provision:

Section 109.3. Persons who shall violate a provision of this code or shall fail to comply with any of the requirements thereof or who shall erect, install, alter, repair or do work in violation of the approved construction documents or directive of the code official, or of a permit or certificate used under the infraction, and shall be subject to a fine as follows:

- a. The fine for any first violation of Article II shall be \$100.00.
- b. The fine for any violation which the violator has, within the past two years, been found in violation of once before, shall be \$250.00.
- c. The fine for any violation which the violator has, within the past two years, been found in violation of twice before, shall be \$500.00.

The imposition of one penalty for any violation shall not excuse the violations or permit it to continue. All such persons shall be required to correct or remedy such situation or defects within a reasonable time, and, when not otherwise specified, each act or violation and every day upon which such violation shall occur shall constitute a separate offense.

The application of the penalties of this section shall not be held to prevent the enforced removal of prohibited conditions by injunctive or other relief.

Each day that a violation continues after due notice has been served shall be deemed a separate violation.

Section 111.4 – insert \$100 or more than \$500

Section 901.2 – Fire Sprinkler Plan Submittal (Added to read)

All fire sprinkler plans shall be submitted to the *fire official* for review. The *fire official* may request review of the sprinkler plans by a third party. The third party shall be included on a list of companies approved by the Charter Township of Ypsilanti Fire Prevention Bureau. The Charter Township of Ypsilanti Fire Prevention Bureau shall witness all required tests and field inspections of all fire sprinkler systems.

- a. A list of approved companies will be available in the Fire Prevention Bureau and the Office of Community Standards.
- b. No company will be allowed to review its own plans.

Section 906.1 - Residential Fire Extinguisher Requirements Rental Units. (Added to read)

- a. It shall be the responsibility of the owner(s) of single family and multiple family rental units to provide each living unit with a portable fire extinguisher.
- b. The fire extinguisher shall have a minimum 1A-10BC rating or higher, and shall be mounted in a readily accessible location within each dwelling unit. Each extinguisher shall be tagged to include a maintenance and inspection record and must be operable at all times.
- c. It shall be the owner's responsibility to maintain the extinguisher in accordance with NFPA 10, and such maintenance shall include, but is not limited to, recharging the extinguisher of the unit which was discharged when attempting to extinguish a documented fire. For the purpose of this section, a documented fire shall mean any fire that the Ypsilanti Township Fire Department has responded to and/or has a record of. In all other cases it shall be the responsibility of the resident to recharge the extinguisher.
- d. The resident of a single family or multiple family rental unit shall be responsible to advise the building owner, or his designated agent, whenever a required fire extinguisher is missing, damaged, discharged or in need of service.
- e. Anyone tampering with, damaging or interfering with the effectiveness of a fire extinguisher shall be in violation of this code.

Section 907.2 - Minimum Smoke Detection Requirements Rental Units. (Added to read)

- a. Each apartment, suite, or sleeping area of every single or multiple dwelling units shall be provided with a minimum of one smoke detector capable of sensing visible or invisible products of combustion.
- b. The smoke detector shall be approved or listed by recognized or independent testing laboratories and, when actuated, shall provide an alarm suitable to warn the occupants within the individual dwelling unit.
- c. A minimum of one smoke detector shall be located in the immediate area of all sleeping quarters.
- d. All single family and multiple dwelling units, including duplexes, shall comply with this section.
- e. It shall be the responsibility of the owner(s) of each rental unit to install and maintain in operating condition smoke detectors in each dwelling unit as herein provided.

f. All devices, combination of devices and equipment required herein are to be installed in conformance with the Michigan Building and Residential Codes and this section.

g. At least one smoke detector shall be installed to protect each sleeping area. A sleeping area is defined as the area or areas of the family living unit in which the bedrooms or sleeping rooms are located. When bedrooms ordinarily used for sleeping are separated by other used areas, such as kitchens or living rooms, but not bathrooms or closets, they shall be considered as separate sleeping areas for the purpose of this section.

F. Geographic Limits Referred to in Certain Sections of the Code.

The geographic limits referred to in certain sections of the 2012 International Fire Code are hereby established as follows:

Section 5704.2.9.6.1 (geographic limits in which the storage of Class I and Class II liquids in above-ground storage tanks outside of buildings is prohibited): *Storage of greater than 50 gallons is prohibited within 50 feet of a structure.*

Section 5706.2.4.4 (geographic limits in which the storage of Class I and Class II liquids in above-ground ground storage tanks is prohibited): *Amend to add the following language:*

- a. *An above ground storage tank shall not be erected less than 300 feet (92 meters) from any of the following:*
 - i. *a mineshaft.*
 - ii. *an air escape shaft for a mine.*
 - iii. *a school*
 - iv. *a church*
 - v. *a hospital*
 - vi. *a theater*
 - vii. *assembly occupancies for 50 or more persons.*
- b. *The above ground storage tank, loading operation, or unloading operation shall not be installed closer than 25 feet (7.6 meters) plus 1 inch (25 millimeters) per 1,000 volts, measured horizontally from the nearest conductor or power lines, except that a service entrance and service line may be closer than 25 feet (7.6 meters), but shall not be over a tank loading or unloading area.*

Section 5806.2 (geographic limits in which the storage of flammable cryogenic fluids in stationary containers is prohibited): *Amend to add the following language:*

- a. *Stationary containers with storage greater than 45 gallons is prohibited within 50 feet of the following:*
 - i. *Places of public assembly*
 - ii. *Non-ambulatory patient areas*
- b. *Stationary containers with storage greater than 45 gallons is prohibited within 15 feet of the following:*
 - i. *Combustible materials such as paper, leaves, weeds, dry grass or debris exposure hazards*

- c. *Stationary containers with storage greater than 45 gallons is prohibited within 10 feet of the following:*
 - i. *Air intakes*

- d. *Stationary containers with storage greater than 45 gallons is prohibited within 5 feet of the following:*
 - i. *Lot lines*

Section 6104.2 (geographic limits in which the storage of liquefied petroleum gas is restricted for the protection of heavily populated or congested areas): *Amend to add the following language:*

For the protection of heavily populated and congested areas, the maximum aggregate capacity of any installation of liquefied petroleum gas shall not exceed a water capacity of 2,000 gallons within 50 feet (15.2 meters) of a structure.

G. Rights and Remedies are Cumulative.

The rights and remedies provided herein are cumulative and in addition to any other remedies provided by law.

H. Severability Clause.

That if any section, subsection, sentence, clause or phrase of this ordinance is, for any reason, held to be unconstitutional, such decision shall not affect the validity of the remaining portions of this ordinance. The Charter Township of Ypsilanti hereby declares that it would have passed this ordinance, and each section, subsection, clause or phrase thereof, irrespective of the fact that any one or more sections, subsection, sentences, clauses or phrases by declared unconstitutional.

I. Publication.

This Ordinance shall be published in a newspaper of general circulation as required by law.

J. Effective Date.

This Ordinance shall be effective upon publication in a newspaper of general circulation as required by law.

I, Karen Lovejoy Roe, Clerk of the Charter Township of Ypsilanti, County of Washtenaw, State of Michigan hereby certify approval of the first reading of Proposed Ordinance No. 2015-453 by the Charter Township of Ypsilanti Board of Trustees assembled at a regular meeting held on October 6, 2015. The second reading is scheduled to be heard on October 20, 2015.

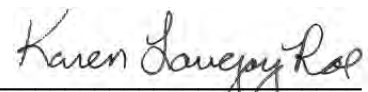

Karen Lovejoy Roe, Clerk
Charter Township of Ypsilanti

RESOLUTION 2015-42

Rezoning of 2590 East Michigan Avenue, Parcel K-11-01-300-004, From its Current MHP (Mobile Home Park) District Zoning Classification to B-3 (General Business) District Classification

Whereas, at its regularly scheduled meeting held **August 25, 2015**, the Charter Township of Ypsilanti (Township) Planning Commission (Commission) recommended that the Township Board approve a rezoning request for a certain parcel of property comprising 5.55 acres, commonly identified as 2590 East Michigan Avenue, Parcel ID K-11-01-300-004, from the MHP (mobile home park) zoning district to the B-3 (general business district) zoning district; and

Whereas, the rezoning request is consistent with the Township's current Master Plan; and

Whereas, proposed Ordinance No. 2015-454 rezones 2590 East Michigan Avenue, Parcel ID K-11-01-300-004, from MHP District to B-3 District zoning classification; and

Whereas, the Township Board of Trustees agrees that the rezoning is appropriate.

Now Therefore,

Be it resolved that the Charter Township of Ypsilanti hereby adopts and incorporates by reference Ordinance No. 2015-454 attached hereto, by reference, in its entirety.

ORDINANCE 2015-454

***An Ordinance Amending Ordinance No. 74,
Township Zoning Ordinance, So As To Rezone
2590 East Michigan Avenue, being Parcel ID K-11-01-300-004,
From Its Current MHP (mobile home park) District Zoning
Classification To B-3 (general business) District Zoning Classification***

The Charter Township of Ypsilanti hereby ordains that

Ordinance No. 74, adopted May 18, 1994, shall be amended as follows:

Real Property consisting of 5.55 acres of land located at 2590 East Michigan Avenue, also known as Parcel ID K-11-01-300-004, and more particularly described as follows:

See attached legal description labeled "Attachment A" shall be rezoned from its current MHP (mobile home park) District zoning classification to the B-3 (general business) District zoning classification.

The Zoning Map, as incorporated by reference, in the Charter Township of Ypsilanti Zoning Ordinance is hereby amended by the rezoning of the afore-described parcel of property from its MHP District zoning classification to the B-3 District zoning classification.

Severability

In the event that any one or more sections, provisions, phrases or words of this ordinance shall be found to be invalid by a Court of competent jurisdiction, such holding shall not affect the validity nor the enforceability of the remaining sections, provisions, phrases or words of this Ordinance unless expressly so determined by a Court of competent jurisdiction.

Non Exclusivity

The prohibitions and penalties provided for in this Ordinance shall be in addition to, and not exclusive of, other prohibitions and penalties provided for by other law, ordinance, or rule/regulation.

Publication

This Ordinance shall be published in a newspaper of general circulation as required by law.

Effective date

This Ordinance shall become effective upon publication in a newspaper of general circulation as required by law.

I, Karen Lovejoy Roe, Clerk of the Charter Township of Ypsilanti, County of Washtenaw, State of Michigan hereby certify approval of the first reading of Proposed Ordinance No. 2015-454 by the Charter Township of Ypsilanti Board of Trustees assembled at a regular meeting held on October 6, 2015. The second reading is scheduled to be heard on October 20, 2015.



Karen Lovejoy Roe, Clerk
Charter Township of Ypsilanti

CHARTER TOWNSHIP OF YPSILANTI

OFFICE OF COMMUNITY STANDARDS

Building Safety • Planning & Zoning • Ordinance Enforcement

Memorandum

To: Township Board of Trustees
Cc: Lisa Garrett, Deputy Clerk
From: Joe Lawson, Planning Director
Date: September 8, 2015
Re: Recommendation to approve first reading of the requested rezoning of the parcel formally known as the Kingsley Mobile Home Park located at 2590 East Michigan Avenue, parcel K-11-01-300-004 from MHP (mobile home park) to B-3 (general business). A public hearing was held before the Planning Commission on August 25, 2015.

As the Board may be aware, on August 25, 2015 the Township Planning Commission held a public hearing to consider the request of staff to rezone the 5.55 acre Township owned parcel formally known as the Kingsley Mobile Home Park and located at 2590 East Michigan Avenue, parcel K-11-01-300-004 from MHP (mobile home park) to B-3 (general business).

As with any application for rezoning, staff reviewed the requested rezoning in relation to the surround zoning districts, current land uses, the future land use goals of the Township and the future land use map adopted as part of the overall Township Master Plan.

During this review, staff confirmed that the requested rezoning application met the goals and objectives of the Township Master Plan, including the future land use map.

I have attached a copy of the staff report that was provided to the Commission for your review and consideration.

At the conclusion of the public hearing, the Commission filed the following motion recommending approval of the request to the Board of Trustees:

Motion: *by Krieg "to recommend approval to the Board of Trustees the request of Charter Township of Ypsilanti to rezone the 5.55 acre parcel formerly known as the Kingsley Mobile Home Park and located at 2590 East Michigan Avenue, parcel K-11-01-300-004 from MHP (mobile home park) to B-3, General Business as the request is consistent with the criteria established in the Township Zoning Ordinance Section 2704, "criteria for amendments to the zoning map".*

Support: Peterson

Motion carries: All

2590 East Michigan Ave
Board Recommendation - Rezoning

Recommendation:

Staff recommends that the Board of Trustee approve the first reading of the staff request to rezone the property located at 2590 East Michigan Avenue, parcel K-11-01-300-004 as noted within the planning commission recommendation dated August 25, 2015 from MHP, mobile home park to B-3, general business. This recommendation is based upon the opinion of staff and the Commission that the petition is consistent with the criteria established within section 2704 of the Township Zoning Ordinance

Should you have any questions or concerns prior to meeting date, please feel free to contact me at your convenience.

Current Zoning Map Designation

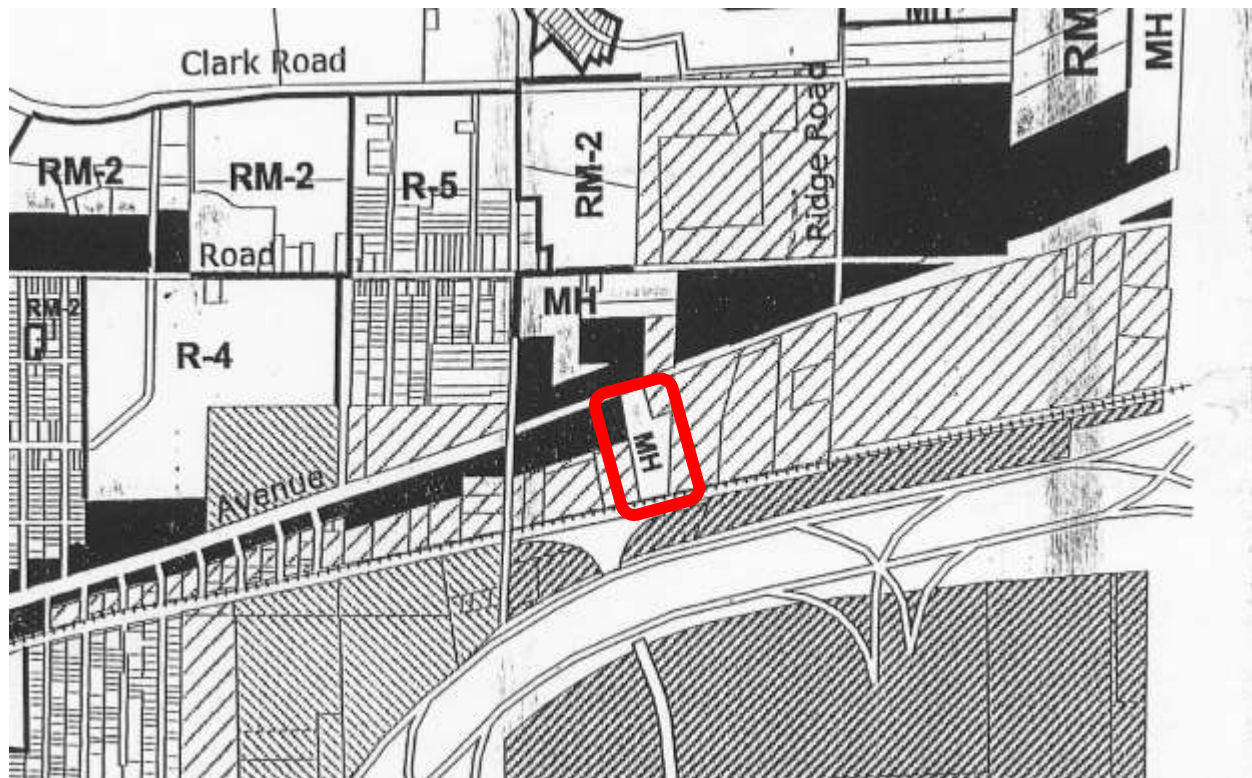

Legend	
R-1	R1 One-Family Residential
R-2	R2 One-Family Residential
R-3	R3 One-Family Residential
R-4	R4 One-Family Residential
R-5	R5 One-Family Residential
RM-1	RM-1 Multi-Family Residential
RM-2	RM-2 Multi-Family Residential
RM-3	RM-3 Multi-Family Residential
RM-4	RM-4 Multi-Family Residential
MH	MH Mobile Home Park
OS-1	OS-1 Office Service
B-1	B-1 Local Business
B-2	B-2 Community Business
B-3	B-3 General Business
F-S	F-S Freeway Service
RO	RO Ind. Research Office
I-1	I-1 Light Industrial
I-2	I-2 General Industrial
I-3	I-3 Heavy Industrial
I-C	I-C Industrial Corridor
P-1	P-1 Vehicular Parking
PD-#	PD-# Planned Development

CHARTER TOWNSHIP OF YPSILANTI

PLANNING COMMISSION

7200 S. Huron River Drive, Ypsilanti, MI 48197

Staff Report

Petition to Rezone Real Property

Recommendation to the Township Board

2590 East Michigan Avenue,

Parcel K-11-01-300-004

August 18, 2015

CASE LOCATION AND SUMMARY

A petition has been initiated by the Office of Community Standards requesting consideration to rezone the 5.55 acre parcel, at 2590 East Michigan Avenue, Parcel K-11-01-300-004, formally known as the Kingsley Mobile Home Park from MHP (Mobile Home Park) to B-3, General Business.

APPLICANT

Charter Township of Ypsilanti
7200 S. Huron River Rd
Ypsilanti, MI 48198

CROSS REFERENCES

Zoning Ordinance citations:

- Article XXVII; Section 2701 – Changes and Amendments
- Article XI; Section 1100 – B3 General Business District
- Article VII; Section 700 – MHP Mobile Home Park District

SUBJECT SITE USE, ZONING AND COMPREHENSIVE PLAN

The Comprehensive Plan designates this site for Commercial development. The subject property is currently vacant land zoned MHP, Mobile Home Park.



ADJACENT USES, ZONING AND COMPREHENSIVE PLAN

Direction	Use	Zoning	Master Plan
North	Restaurant	B3	Commercial
South	Railroad Use	IC	Industrial
East	Vacant Industrial	I1	Industrial
West	MF Residential	I1	Commercial

ANALYSIS

Section 2704 of the Zoning Ordinance provides criteria for amendment of the zoning map. This review is based on those rezoning criteria and the most recent Master Plan update.

- a. *Consistency with the goals, policies and future land use map of the Charter Township of Ypsilanti Master Plan, including any sub-area or corridor plans. If conditions have changed since the master plan was adopted, the rezoning may be found to be consistent with recent development trends in the area.*
 - The requested rezoning is consistent with the Future Land Use Map of the Township Master Plan which recommends "Commercial" uses for the subject properties. This rezoning request is also consistent with the goals stated in the Plan.
- b. *Compatibility of the site's physical, geological, hydrological and other environmental features with all uses permitted in the proposed zoning district compared to uses permitted under current zoning.*
 - There is no evidence indicating that the site contains any environmental features that would restrict development under either the current or proposed zoning designations.
- c. *Evidence the applicant cannot receive a reasonable return on investment through developing the property with at least one of the uses permitted under the current zoning.*
 - Under the current zoning, only a mobile home park is permitted for development. The property noted within this application would not be available to a non-residential development without the requested zoning amendment.
- d. *The compatibility of all uses permitted in the proposed zoning district with surrounding uses and zoning in terms of land suitability, impacts on the environment, density, nature of use, traffic impacts, aesthetics, infrastructure*

and potential influence on property values compared to uses permitted under current zoning.

- As the proposed B3 zoning designation prohibits the outdoor storage of goods or materials, the impact to any neighboring property will be limited. The property located to the west is a multiple-family apartment complex; the property to the east is vacant that will not be impacted by the proposed zoning change. It should be noted the adjacent multiple-family residential dwelling units should not be impacted by the proposed zoning change as the B3 zone should serve as a buffer from the higher intensity industrial zones to the east.
- e. *The capacity of township utilities and services are sufficient to accommodate all the uses permitted in the requested district without compromising the health, safety and welfare of the township.*
- Public water and sewer and other necessary utilities are available in this area to serve the site. Commercial uses on this site will not create a significant increase in demand for utilities. However, we defer to the engineering consultant and the Ypsilanti Community Utilities Authority for more detailed analysis of utility impacts at the time of redevelopment. Storm water drainage will also need to be addressed with any redevelopment of the site.
- f. *The capacity of the street system to safely and efficiently accommodate the expected traffic generated by uses permitted in the requested zoning district. A traffic impact study in accordance with the requirements of the township traffic impact study ordinance shall be provided if the proposed rezoning district permits uses that could generate 100 or more directional trips during the peak hour, or at least 1,000 more trips per day than the majority of the uses that could be developed under the current zoning, as determined by the community and economic development department.*
- A traffic impact study will be completed upon the Township receiving a redevelopment proposal.
- g. *The apparent demand for the types of uses permitted in the requested zoning district in the township, and surrounding area, in relation to the amount of land in the township, and surrounding area, currently zoned and available to accommodate the demand.*

- The property noted within this request is currently vacant. The redevelopment of this property as a mobile home park is not consistent with the goals of the master plan. If approved, the rezoning would permit the development of the property to a use other than Mobile Home Park and would also bring the property into compliance with the master plan and future land use map. Based on the occupancy of other mobile home parks within the Township, demand for this use is down which favors a reduction in the total amount of land area available for that use.
- h. The boundaries of the requested zoning district are sufficient to meet the dimensional regulations for the zoning district listed in Article XX Schedule of Regulations.*
- The existing parcel meets all requirements for minimum land area per and road frontage per section 2001 of the Township Zoning Ordinance.
- i. If a rezoning is appropriate, the requested zoning district shall be more appropriate from the township's perspective than another zoning district.*
- If the zoning is to be changed, then the proposed B3 zoning is the most appropriate district, consistent with the Master Plan and other planned and built development in the area.
- j. The requested rezoning will not create an isolated and unplanned spot zone.*
- The requested B3 zoning on this site would be consistent with the planned future land uses for this area and is therefore not an unplanned spot zone.
- k. The request has not previously been submitted within the past one year, unless conditions have changed or new information has been provided.*
- A rezoning request has not been considered on this site within the past year.

RECOMMENDATION

As indicated in the foregoing analysis, staff has not discovered any reasons to reject the request for rezoning. If approved, the request will be consistent with the Township's Master Plan and the future land use map. Staff recommends approval of the request as presented. As noted above, this request requires the Planning Commission to make a recommendation to the Township Board.

Therefore, it is the recommendation of staff that the Planning Commission approve a motion to recommend approval to the Township Board.

Suggested Motions: *The following suggested motions are intended to assist the Commission in making the desired motion of their choice. The Commission may utilize, add or reject any motion and/or conditions suggested herein as they deem appropriate.*

Motion to approve:

"I move to recommend approval to the Board of Trustees the request of The Charter Township of Ypsilanti to rezone the 5.55 acre parcel formally known as the Kingsley Mobile Home park and located at 2590 East Michigan Avenue, parcel K-11-01-300-004 from MHP (mobile home park) to B3, (general business) as the request is consistent with the criteria established in the Township Zoning Ordinance Section 2704, criteria for amendments to the zoning map."

Respectfully submitted,

Mike Davis

Mike Davis
Assistant Planner

Lawson – added that when she has the State inspect for the six, ask if they can give her some guidance as to whether she actually does have the square footage for twelve. That was a question they discussed, and they don't know the square footage that is available versus what is required. If they could get some guidance in that regard, it would be helpful.

- c. **PUBLIC HEARING – REQUEST TO REZONE – CHARTER TOWNSHIP OF YPSILANTI** – to consider a recommendation to the Board of Trustees in order to rezone the 6.52 acre parcel formally known as the Ypsi-Mobile Village mobile home park from MHP (Mobile Home Park) to B-3, General Business. The property is located at 953 East Michigan Avenue, Parcel K-11-10-205-039.

Reiser – noted that the applicant was the Township, and that this was something that came up in a work session last month and the commission has been apprised of this. He noted Director Lawson or Intern Mike Davis might wish to speak on this.

Davis – stated that this was discussed at the last work session. There is not a whole lot of new information other than that the current zoning is not in compliance with the Master Plan. The B3 brings it into compliance and gives it more development possibility, moving it beyond just the mobile home zone, which only allows other mobile homes. As you see in both reports, the demand for mobile home parks is down.

PUBLIC PORTION OPEN

None

PUBLIC PORTION CLOSED

Motion: *by Krieg to recommend approval to the Board of Trustees the request of Charter Township of Ypsilanti to rezone parcel K-11-10-205-039 to from MHP (mobile home park) to B-3, General Business as the request is consistent with the criteria established in the Township Zoning Ordinance Section 2704, "criteria for amendments to the zoning map".*

Support: *Richie*

Motion carries: *All*

- d. **PUBLIC HEARING – REQUEST TO REZONE – CHARTER TOWNSHIP OF YPSILANTI** – to consider a recommendation to the Board of Trustees in order to rezone the 5.55 acre parcel formally known as the Kingsley Mobile Home Park from MHP (Mobile Home Park) to B-3, General Business. The property is located at 2590 East Michigan Avenue, Parcel K-11-01-300-004.

Davis – stated that this property is currently vacant and the redevelopment of this property as a mobile home park is not consistent with the Master Plan. Approving the rezoning would allow the parcel to be developed as general business. This would also

bring the property into compliance with our Master Plan and our Future Land Use Plan Map. They have determined based on the occupancy of other mobile home parks in the Township that there is a lack in demand for this use, which favors a reduction in the overall land.

PUBLIC PORTION OPEN

None

PUBLIC PORTION CLOSED

Motion: *by Krieg to recommend approval to the Board of Trustees the request of Charter Township of Ypsilanti to rezone the 5.55 acre parcel formerly known as the Kingsley Mobile Home Park and located at 2590 East Michigan Avenue, parcel K-11-01-300-004 from MHP (mobile home park) to B-3, General Business as the request is consistent with the criteria established in the Township Zoning Ordinance Section 2704, "criteria for amendments to the zoning map".*

Support: *Peterson*

Motion carries: *All*

6. Old Business
 - a. **None**
7. New Business
 - a. **None**
8. Open discussion for issues not on the agenda
 - a. Correspondence received – None
 - b. Planning Commission Members – None
 - c. Members of the Audience – None
9. Township Board representative report:
 - a. None
10. Zoning Board of Appeals representative report –
 - a. none
11. Township Attorney report - none

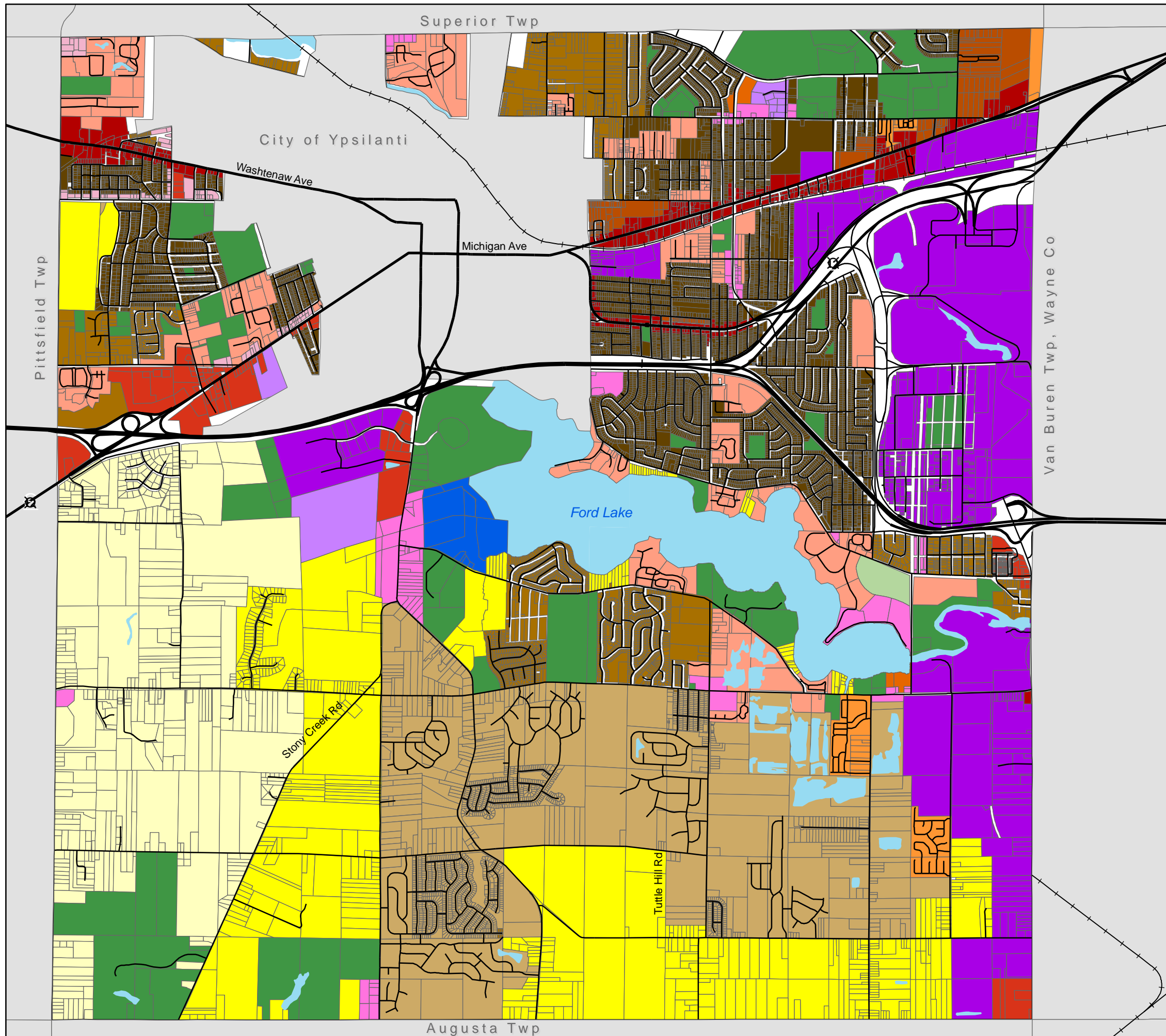

Future Land Use Map

Master Plan Update
Ypsilanti Township
Washtenaw County, MI

- SFR-1
- SFR-2
- SFR-3
- SFR-4
- SFR-5
- MFR-2
- MFR-3
- MFR-4
- MFR-5
- Town Center (See inset map on page X)
- Office
- Neighborhood Commercial
- General Commercial
- Urban Commercial Corridor
- RD
- Industrial
- Private Recreation
- Public
- Water



Sources: MCGI, Ypsilanti Twp

Draft: March 2014

Ypsi Twp. 2590 E. Michigan

AFFIDAVIT OF PUBLICATION

CHARTER TOWNSHIP OF YPSILANTI NOTICE OF PUBLIC HEARING Take notice that a petition has been filed with the Ypsilanti Township Planning Commission requesting to rezone the 5.55 acre parcel formally known as Kingsley Mobile Home Park from MHP (Mobile Home Park) to B-3 General Business for property located at: 2590 E. Michigan - K-11-01-300-004 The Planning Commission invites the public to attend a public hearing on this application to be held on TUESDAY, August 25, 2015 at approximately 6:30 P.M. in the Civic Center Board Room (7200 S. Huron River Drive) to comment on or raise objections, if any, to this petition. The file and map are available for inspection at the Civic Center in the Office of Community Standards or call 734.485.3943 for more information. Please address written comments to: Ypsilanti Township Planning Commission, 7200 S. Huron River Drive, Ypsilanti, MI 48197 or email to Planning@ytown.org. Laurence Kreig, Secretary Legal Description YP#1-49 COM AT SW COR OF SEC, TH N 1418.39 FT IN W LINE OF SEC, TH DEFLECTING 70 DEG 55'RIGHT 940.30 FT IN CENT OF HWY FOR PL OF BEG, TH CONTINUING NELY 211.9 FT IN CENT OF HWY, TH DEFL 96 DEG 17' RIGHT 271 FT, TH DEFL 94 DEG 10' LEFT 169.6 FT, TH DEFL 107 DEG 16' RIGHT 644 FT, TH DEFL 78 DEG 01' RIGHT 231 FT, TH DEFL 88 DEG 41' RIGHT 858.63 FT TO PL OF BEG, BEING PART OF SW 1/4 SEC 1 T3S-R7E 5.55 AC. PROP: KINGSLEY MOBILE PARK 08/03

(Affidavit of Publisher)

STATE OF MICHIGAN,
ss.
COUNTY OF WASHTENAW

The undersigned, an employee of the publisher of Washtenaw County Legal News, having knowledge of the facts, being duly sworn deposes and says that a notice, a true copy of which is annexed hereto, was published in Washtenaw County Legal News a newspaper circulated in Washtenaw County on August 3, 2015 A.D.



Sheila Pursglove

Subscribed and sworn before me on this 3rd day of August 2015 A.D.



Vicky Blanshard

Notary Public Washtenaw County, Michigan. My commission expires: August 9, 2020 Acting in Washtenaw County, Michigan.

Attorney: Ypsilanti Twp. - Ypsilanti Twp.
AttorneyFile#:
Notice#: 1244870

RESOLUTION 2015-43

Rezoning of 953 East Michigan Ave, Parcel K-11-10-205-039, From Its Current MHP (Mobile Home Park) District Zoning Classification to B-3 (General Business) District Zoning Classification

Whereas, at its regularly scheduled meeting held **August 25, 2015**, the Charter Township of Ypsilanti (Township) Planning Commission (Commission) recommended that the Township Board approve a rezoning request for a certain parcel of property comprising 6.52 acres, commonly identified as 953 East Michigan Avenue, Parcel ID K-11-10-205-039, from the MHP (mobile home park) zoning district to the B-3 (general business district) zoning district; and

Whereas, the rezoning request is consistent with the Township's current Master Plan; and

Whereas, proposed Ordinance No. 2015-455 rezones 953 East Michigan Avenue, Parcel ID K-11-10-205-039, from MHP District to B-3 District zoning classification; and

Whereas, the Township Board of Trustees agrees that the rezoning is appropriate.

Now Therefore,

Be it resolved that the Charter Township of Ypsilanti hereby adopts and incorporates by reference Ordinance No. 2015-455 attached hereto, by reference, in its entirety.

PROPOSED ORDINANCE 2015-455

***An Ordinance Amending Ordinance No. 74,
Township Zoning Ordinance, So As To Rezone
953 East Michigan Avenue, being Parcel ID K-11-10-205-039,
From Its Current MHP (mobile home park) District Zoning
Classification To B-3 (general business) District Zoning Classification***

The Charter Township of Ypsilanti hereby ordains that

Ordinance No. 74, adopted May 18, 1994, shall be amended as follows:

Real Property consisting of 6.52 acres of land located at 953 East Michigan Avenue, also known as Parcel ID K-11-10-205-039, and more particularly described as follows:

See attached legal description labeled "Attachment A" shall be rezoned from its current MHP (mobile home park) District zoning classification to the B-3 (general business) District zoning classification.

The Zoning Map, as incorporated by reference, in the Charter Township of Ypsilanti Zoning Ordinance is hereby amended by the rezoning of the afore-described parcel of property from its MHP District zoning classification to the B-3 District zoning classification.

Severability

In the event that any one or more sections, provisions, phrases or words of this ordinance shall be found to be invalid by a Court of competent jurisdiction, such holding shall not affect the validity nor the enforceability of the remaining sections, provisions, phrases or words of this Ordinance unless expressly so determined by a Court of competent jurisdiction.

Non Exclusivity

The prohibitions and penalties provided for in this Ordinance shall be in addition to, and not exclusive of, other prohibitions and penalties provided for by other law, ordinance, or rule/regulation.

Publication

This Ordinance shall be published in a newspaper of general circulation as required by law.

Effective date

This Ordinance shall become effective upon publication in a newspaper of general circulation as required by law.

I, Karen Lovejoy Roe, Clerk of the Charter Township of Ypsilanti, County of Washtenaw, State of Michigan hereby certify approval of the first reading of Proposed Ordinance No. 2015-455 by the Charter Township of Ypsilanti Board of Trustees assembled at a regular meeting held on October 6, 2015. The second reading is scheduled to be heard on October 20, 2015.



Karen Lovejoy Roe, Clerk
Charter Township of Ypsilanti

CHARTER TOWNSHIP OF YPSILANTI

OFFICE OF COMMUNITY STANDARDS

Building Safety • Planning & Zoning • Ordinance Enforcement

Memorandum

To: Township Board of Trustees
Cc: Lisa Garrett, Deputy Clerk
From: Joe Lawson, Planning Director
Date: September 8, 2015
Re: Recommendation to approve first reading of the requested rezoning of the parcel formally known as the Ypsi-Mobile Village located at 953 East Michigan Avenue, parcel K-11-10-205-039 from MHP(mobile home park) to B-3 (general business). A public hearing was held before the Planning Commission on August 25, 2015.

As the Board may be aware, on August 25, 2015 the Township Planning Commission held a public hearing to consider the request of staff to rezone the 6.58 acre Township owned parcel formally known as the Ypsi-Mobile Village mobile home park and located at 953 East Michigan Avenue, parcel K-11-10-205-039 from MHP (mobile home park) to B-3 (general business).

As with any application for rezoning, staff reviewed the requested rezoning in relation to the surround zoning districts, current land uses, the future land use goals of the Township and the future land use map adopted as part of the overall Township Master Plan.

During this review, staff confirmed that the requested rezoning application met the goals and objectives of the Township Master Plan, including the future land use map.

I have attached a copy of the staff report that was provided to the Commission for your review and consideration.

At the conclusion of the public hearing, the Commission filed the following motion recommending approval of the application to the Board of Trustees:

Motion: *by Krieg "to recommend approval to the Board of Trustees the request of Charter Township of Ypsilanti to rezone parcel K-11-10-205-039 to from MHP (mobile home park) to B-3, General Business as the request is consistent with the criteria established in the Township Zoning Ordinance Section 2704, "criteria for amendments to the zoning map".*

Support: *Richie*

Motion carries: *All*

953 East Michigan Ave
Board Recommendation - Rezoning

Recommendation:

Staff recommends that the Board of Trustee approve the first reading of the staff request to rezone the property located at 953 East Michigan Avenue, parcel K-11-10-205-039 as noted within the planning commission recommendation dated August 25, 2015 from MHP, mobile home park to B-3, general business. This recommendation is based upon the opinion of staff and the Commission that the petition is consistent with the criteria established within section 2704 of the Township Zoning Ordinance

Should you have any questions or concerns prior to meeting date, please feel free to contact me at your convenience.

Current Zoning Map Designation

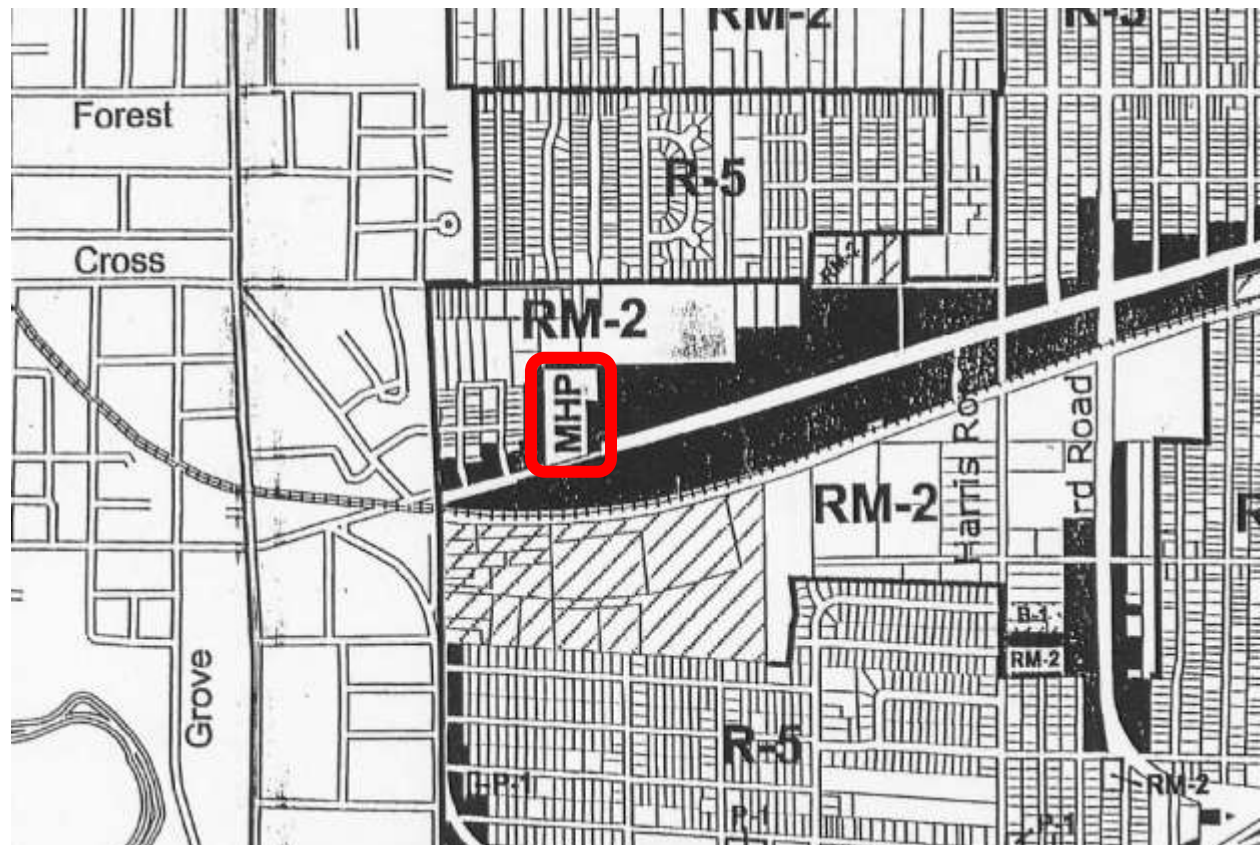

Legend

R-1	R-1 One-Family Residential	B-1	Local Business
R-2	R-2 One-Family Residential	B-2	Community Business
R-3	R-3 One-Family Residential	B-3	General Business
R-4	R-4 One-Family Residential	F-S	Freeway Service
R-5	R-5 One-Family Residential	RO	Ind. Research Office
RM-1	RM-1 Multi-Family Residential	I-1	Light Industrial
RM-2	RM-2 Multi-Family Residential	I-2	General Industrial
RM-3	RM-3 Multi-Family Residential	I-3	Heavy Industrial
RM-4	RM-4 Multi-Family Residential	IC	Industrial Commercial
MH	Mobile Home Park	P-1	Vehicular Parking
OS-1	Office Service	PD-#	Planned Development

CHARTER TOWNSHIP OF YPSILANTI

PLANNING COMMISSION

7200 S. Huron River Drive, Ypsilanti, MI 48197

Staff Report

Petition to Rezone Real Property

Recommendation to the Township Board

**953 East Michigan Avenue,
Parcel K-11-10-205-039**

August 18, 2015

CASE LOCATION AND SUMMARY

A petition has been initiated by the Office of Community Standards requesting consideration to rezone the 6.52 acre parcel located at 953 East Michigan Avenue, Parcel K-11-10-205-039 and formally known as the Ypsi-Mobile Village from MHP, Mobile Home Park to B-3, General Business.

APPLICANT

Charter Township of Ypsilanti
7200 S. Huron River Rd
Ypsilanti, MI 48197

CROSS REFERENCES

Zoning Ordinance citations:

- Article XXVII; Section 2701 – Changes and Amendments
- Article XI; Section 1100 – B3 General Business District
- Article VII; Section 700 – MHP Mobile Home Park District

SUBJECT SITE USE, ZONING AND COMPREHENSIVE PLAN

The Comprehensive Plan designates this site for Commercial development. The subject property is currently vacant land zoned MHP, Mobile Home Park.



ADJACENT USES, ZONING AND COMPREHENSIVE PLAN

Direction	Use	Zoning	Master Plan
North	Vacant Residential	RM2	MF Residential
South	Vacant Commercial	B-3	Commercial
East	Church Use	B-3	Commercial
West	MF Residential / Motel	RM2 / B3	MF Residential / Commercial

ANALYSIS

Section 2704 of the Zoning Ordinance provides criteria for amendment of the zoning map. This review is based on those rezoning criteria and the most recent Master Plan update.

a. *Consistency with the goals, policies and future land use map of the Charter Township of Ypsilanti Master Plan, including any sub-area or corridor plans. If conditions have changed since the master plan was adopted, the rezoning may be found to be consistent with recent development trends in the area.*

- The requested rezoning is consistent with the Future Land Use Map of the Township Master Plan which recommends “Commercial” uses for the subject properties. This rezoning request is also consistent with the goals stated in the Plan.

b. *Compatibility of the site's physical, geological, hydrological and other environmental features with all uses permitted in the proposed zoning district compared to uses permitted under current zoning.*

- There is no evidence indicating that the site contains any environmental features that would restrict development under either the current or proposed zoning designations.

c. *Evidence the applicant cannot receive a reasonable return on investment through developing the property with at least one of the uses permitted under the current zoning.*

- Under the current zoning only a mobile home park is permitted for development. The property noted within this application would not be available to a non-residential development without the requested zoning amendment.

d. *The compatibility of all uses permitted in the proposed zoning district with surrounding uses and zoning in terms of land suitability, impacts on the*

environment, density, nature of use, traffic impacts, aesthetics, infrastructure and potential influence on property values compared to uses permitted under current zoning.

- As the proposed B3 zoning designation prohibits the outdoor storage of goods or materials, the impact to any neighboring property will be limited. The properties located to the west are a commercial motel and multiple-family residences; the property to the east is a church that will not be adversely impacted by the proposed zoning change. The property to the north is vacant multiple-family residential parcels. It should be noted that there are multiple-family residential dwelling units located adjacent to Campbell Avenue. This particular property may be the only property that may be impacted to some extent. Staff would recommend future development include additional buffering between subject property and the existing residential structures.
- e. *The capacity of township utilities and services are sufficient to accommodate all the uses permitted in the requested district without compromising the health, safety and welfare of the township.*
- Public water and sewer and other necessary utilities are available and adequate in this area to serve the site. Commercial uses on this site will not create a significant increase in demand for these utilities. However, we defer to the engineering consultant and the Ypsilanti Community Utilities Authority for more detailed analysis of utility impacts at the time of redevelopment. Storm water drainage will also need to be addressed with any redevelopment of the site.
- f. *The capacity of the street system to safely and efficiently accommodate the expected traffic generated by uses permitted in the requested zoning district. A traffic impact study in accordance with the requirements of the township traffic impact study ordinance shall be provided if the proposed rezoning district permits uses that could generate 100 or more directional trips during the peak hour, or at least 1,000 more trips per day than the majority of the uses that could be developed under the current zoning, as determined by the community and economic development department.*
- A traffic impact study will be completed upon the Township receiving a redevelopment proposal.
- g. *The apparent demand for the types of uses permitted in the requested zoning district in the township, and surrounding area, in relation to the*

amount of land in the township, and surrounding area, currently zoned and available to accommodate the demand.

- The property noted within this request is currently vacant. The redevelopment of this property as a mobile home park is not consistent with the goals of the master plan. If approved, the rezoning would permit the development of the property to a use other than Mobile Home Park and would also bring the property into compliance with the master plan and future land use map. Based on the occupancy of other mobile home parks within the Township, demand for this use is down which favors a reduction in the total amount of land area available for that use.
- h. The boundaries of the requested zoning district are sufficient to meet the dimensional regulations for the zoning district listed in Article XX Schedule of Regulations.*
- The existing parcel meets all requirements for minimum land area per and road frontage per section 2001 of the Township Zoning Ordinance.
- i. If a rezoning is appropriate, the requested zoning district shall be more appropriate from the township's perspective than another zoning district.*
- If the zoning is to be changed, then the proposed B3 zoning is the most appropriate district, consistent with the Master Plan and other planned and built development in the area.
- j. The requested rezoning will not create an isolated and unplanned spot zone.*
- The requested B3 zoning on this site would be consistent with the existing and planned future land uses for this area and is therefore not an unplanned spot zone.
- k. The request has not previously been submitted within the past one year, unless conditions have changed or new information has been provided.*
- A rezoning request has not been considered on this site within the past year.

RECOMMENDATION

As indicated in the foregoing analysis, staff has not discovered any reasons to reject the request for rezoning. If approved, the request will be consistent with

the Township's Master Plan and the future land use map. Staff recommends approval of the request as presented. As noted above, this request requires the Planning Commission to make a recommendation to the Township Board. Therefore, it is the recommendation of staff that the Planning Commission approve a motion to recommend approval to the Township Board.

Suggested Motions: *The following suggested motions are intended to assist the Commission in making the desired motion of their choice. The Commission may utilize, add or reject any motion and/or conditions suggested herein as they deem appropriate.*

Motion to approve:

"I move to recommend approval to the Board of Trustees the request of Charter Township of Ypsilanti to rezone parcel K-11-10-205-039 to from MHP (mobile home park) to B-3, General Business as the request is consistent with the criteria established in the Township Zoning Ordinance Section 2704, "criteria for amendments to the zoning map."

Respectfully submitted,

Mike Davis

Mike Davis
Assistant Planner

Lawson – added that when she has the State inspect for the six, ask if they can give her some guidance as to whether she actually does have the square footage for twelve. That was a question they discussed, and they don't know the square footage that is available versus what is required. If they could get some guidance in that regard, it would be helpful.

- c. **PUBLIC HEARING – REQUEST TO REZONE – CHARTER TOWNSHIP OF YPSILANTI** – to consider a recommendation to the Board of Trustees in order to rezone the 6.52 acre parcel formally known as the Ypsi-Mobile Village mobile home park from MHP (Mobile Home Park) to B-3, General Business. The property is located at 953 East Michigan Avenue, Parcel K-11-10-205-039.

Reiser – noted that the applicant was the Township, and that this was something that came up in a work session last month and the commission has been apprised of this. He noted Director Lawson or Intern Mike Davis might wish to speak on this.

Davis – stated that this was discussed at the last work session. There is not a whole lot of new information other than that the current zoning is not in compliance with the Master Plan. The B3 brings it into compliance and gives it more development possibility, moving it beyond just the mobile home zone, which only allows other mobile homes. As you see in both reports, the demand for mobile home parks is down.

PUBLIC PORTION OPEN

None

PUBLIC PORTION CLOSED

Motion: *by Krieg to recommend approval to the Board of Trustees the request of Charter Township of Ypsilanti to rezone parcel K-11-10-205-039 to from MHP (mobile home park) to B-3, General Business as the request is consistent with the criteria established in the Township Zoning Ordinance Section 2704, “criteria for amendments to the zoning map”.*

Support: *Richie*

Motion carries: *All*

- d. **PUBLIC HEARING – REQUEST TO REZONE – CHARTER TOWNSHIP OF YPSILANTI** – to consider a recommendation to the Board of Trustees in order to rezone the 5.55 acre parcel formally known as the Kingsley Mobile Home Park from MHP (Mobile Home Park) to B-3, General Business. The property is located at 2590 East Michigan Avenue, Parcel K-11-01-300-004.

Davis – stated that this property is currently vacant and the redevelopment of this property as a mobile home park is not consistent with the Master Plan. Approving the rezoning would allow the parcel to be developed as general business. This would also

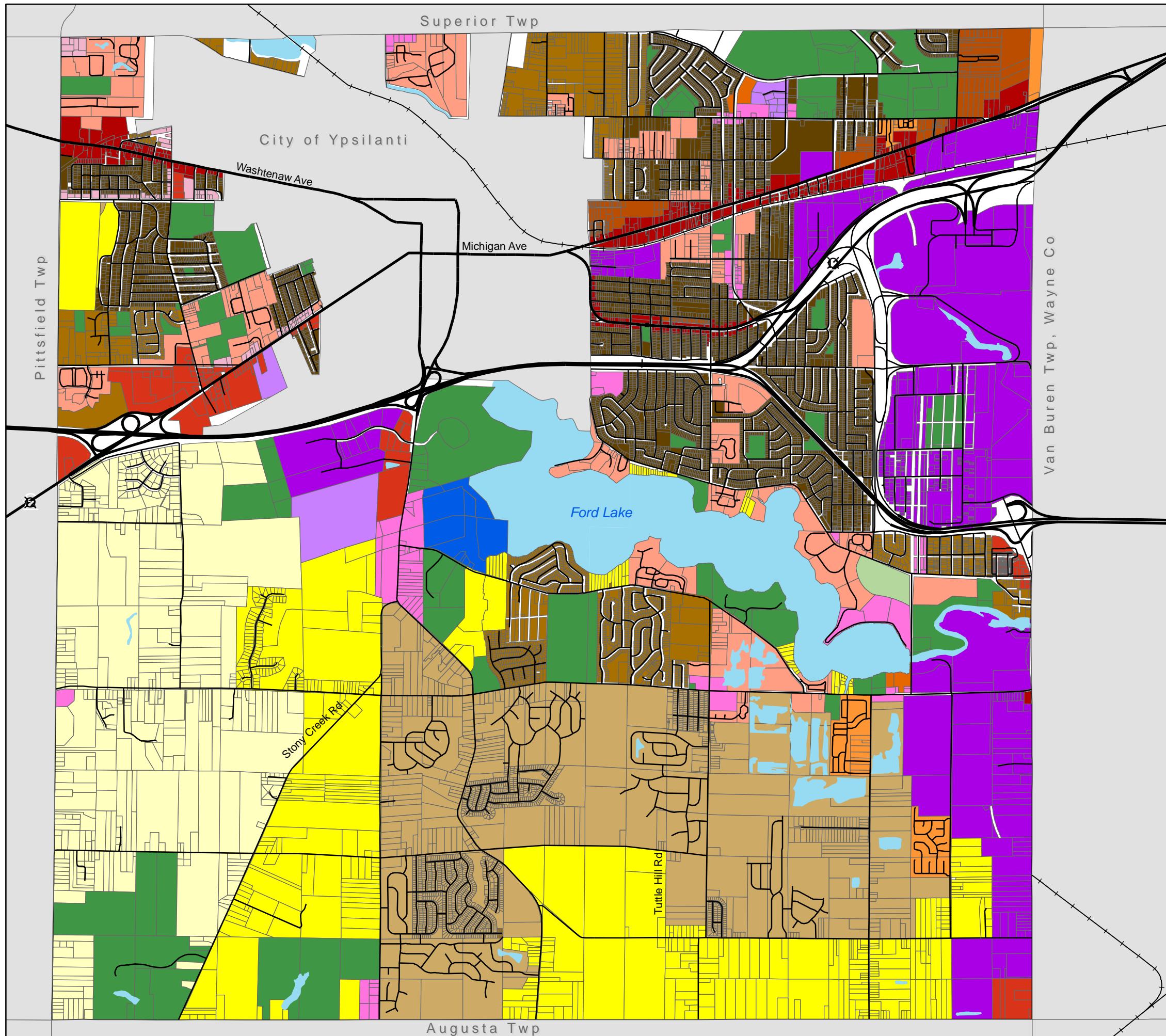

Future Land Use Map

Master Plan Update
Ypsilanti Township
Washtenaw County, MI

- SFR-1
- SFR-2
- SFR-3
- SFR-4
- SFR-5
- MFR-2
- MFR-3
- MFR-4
- MFR-5
- Town Center (See inset map on page X)
- Office
- Neighborhood Commercial
- General Commercial
- Urban Commercial Corridor
- RD
- Industrial
- Private Recreation
- Public
- Water



Sources: MCGI, Ypsilanti Twp

Draft: March 2014

Ypsi Twp.- 953 E. Michigan

AFFIDAVIT OF PUBLICATION

CHARTER TOWNSHIP OF YPSILANTI NOTICE OF PUBLIC HEARING Take notice that a petition has been filed with the Ypsilanti Township Planning Commission requesting to rezone the 6.52 acre parcel formally known as Ypsi-Mobile Village Mobile Home Park from MHP (Mobile Home Park) to B-3 General Business for property located at: 953 E. Michigan - K-11-10-205-039 The Planning Commission invites the public to attend a public hearing on this application to be held on TUESDAY, August 25, 2015 at approximately 6:30 P.M. in the Civic Center Board Room (7200 S. Huron River Drive) to comment on or raise objections, if any, to this petition. The file and map are available for inspection at the Civic Center in the Office of Community Standards or call 734.485.3943 for more information. Please address written comments to: Ypsilanti Township Planning Commission, 7200 S. Huron River Drive, Ypsilanti, MI 48197 or email to Planning@ytown.org. Laurence Kreig, Secretary Legal Description COM AT N 1/4 COR SEC 10, T3S-R7E, YPSI TWP, WASH CTY MI, TH S 00-10-55 E 1089.21 FT ALG N/S 1/4 LN SEC 10; TH S 74-40-01 W 203.49 FT ALG C/L MICH AVE; TH S 75-54-21 W 46.34 FT ALG C/L MICH AVE TO POB; TH S 75-54-21 W 308.26 FT ALG C/L MICH AVE; TH N 00-32-42 W 238.88 FT; TH S 75-48-07 W 145.51 FT; TH N 00-48-07 W 349.25 FT ALG E/L JOHNSONS PL SUB; TH S 88-24-02 W 59.34 FT ALG N/L JOHNSONS PL SUB; TH N 01-06-15 W 228.69 FT; TH S 88-36-37 E 195.77 FT; TH S 00-10-55 E 100.11 FT; TH N 89-49-05 E 313 FT; TH N 89-49-05 E 73.55 FT; TH S 00-10-55 E 245.21 FT; TH S 88-11-19 W 77.01 FT; TH S 00-10-55 E 353.20 FT TO POB. BEING PT OF NW 1/4 SEC 10. CONTAINING 6.93 AC +/- BEING SUBJ TO RIGHTS OF PUBLIC OVER S 50 FT THEREOF AS OCCUPIED BY MICHIGAN AVENUE. (14,986 SQ.FT. OR 0.34 ACRE) 08/03

(Affidavit of Publisher)

STATE OF MICHIGAN,
ss.
COUNTY OF WASHTENAW

The undersigned, an employee of the publisher of Washtenaw County Legal News, having knowledge of the facts, being duly sworn deposes and says that a notice, a true copy of which is annexed hereto, was published in Washtenaw County Legal News a newspaper circulated in Washtenaw County on August 3, 2015 A.D.

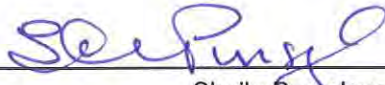

Sheila Pursglove

Subscribed and sworn before me on this 3rd day of August 2015 A.D.



Vicky Blanshard

Notary Public Washtenaw County, Michigan. My commission expires: August 9, 2020 Acting in Washtenaw County, Michigan.

Attorney: Ypsilanti Twp. - Ypsilanti Twp.

AttorneyFile#:

Notice#: 1244574

CHARTER TOWNSHIP OF YPSILANTI
2015 BUDGET AMENDMENT #13

October 20, 2015

584 - GOLF COURSE FUND

Total Increase \$22,138.00

Increase budget for the renovation of hole #3 and drainage for hole #2 & #5 in the amount of \$19,088; and for the purchase of an Evergreen cover for hole #3 at \$1,550; and for an architecture audit by Chris Wilczynski of \$1,500. The total projects cost will be \$22,138. This will be funded by an Appropriation of Prior Year Fund Balance.

Revenues:	Prior Year Fund Balance	584-000-000-699.000	\$22,138.00
		Net Revenues	<u>\$22,138.00</u>
Expenditures:	Capital Outlay	584-584-000-971.000	\$22,138.00
		Net Expenditures	<u>\$22,138.00</u>

Motion to Amend the 2015 Budget (#13):

Move to increase the Golf Course Fund budget by \$22,138 to \$676,450 and approve the department line item changes as outlined.

Park Commission

7200 S. Huron River Drive
Ypsilanti, MI 48197
Phone: (734) 484-0073
Fax: (734) 544-3501
www.ytown.org



Lonnie Scott, Chair
Keith P. Jason, Vice Chair
Debbie Swanson, Secretary
Richard Roe, Treasurer

Commissioners:
Gail Boyd-Palmer
Evan Hayes
Jimmie Maggard
Monica Ross-Williams
Jasmine Mackey

MEMORANDUM

To: Brenda Stumbo, Supervisor
Karen Lovejoy Roe, Clerk
Larry Doe, Treasurer
Ypsilanti Township Board of Trustees

From: Lonnie Scott, Chair of the Ypsilanti Township Park Commission

Subject: Recommendations to the Township Board

Date: October 6, 2015

At our meeting on October 5, 2015, the Park Commission voted unanimously in favor of the following motion:

“The Park Commission recommends that the Township Board review the conceptual splash pad design from Vortex. We further recommend that financing options be pursued to allow for a complete installation of the splash pad. Finally, it is recommended that a joint committee be created to consist of park commissioners and board members to move the project forward.”

This recommendation comes after months of planning and discussion about the project and is the next step needed to move forward. We look forward to working with the Township Board to advance this project.

The proposal may be found in digital format here:
<https://vortex.paperlessproposal.com/v/85643/2728/120410>

Please let me know if you have any questions.

Supervisor
BRENDA L. STUMBO
Clerk
KAREN LOVEJOY ROE
Treasurer
LARRY J. DOE
Trustees
JEAN HALL CURRIE
STAN ELDRIDGE
MIKE MARTIN
SCOTT MARTIN



Charter Township of Ypsilanti

Assessor's Office

7200 S. Huron River Drive
Ypsilanti, MI 48197
Phone: (734) 487-4927
Fax: (734) 484-5159

Date: October 8, 2015

To: Karen Lovejoy Roe,
Ypsilanti Township Clerk

From: Brian McCleery,
Assistant Assessor

Subject: Policy on Sale of Township Owned Property

Enclosed is the **Policy on Sale of Township Owned Property** to be presented for approval by the Township Board at the next work session.

This policy will create the procedure in which the Assessor's Office will sell Township owned land.

Should you or the Board have any questions, please don't hesitate contacting me.

Supervisor
BRENDA L. STUMBO
Clerk
KAREN LOVEJOY ROE
Treasurer
LARRY J. DOE
Trustees
JEAN HALL CURRIE
STAN ELDRIDGE
MIKE MARTIN
SCOTT MARTIN



Charter Township of Ypsilanti

Assessor's Office

7200 S. Huron River Drive
Ypsilanti, MI 48197
Phone: (734) 487-4927
Fax: (734) 484-5159

POLICY ON SALE OF TOWNSHIP OWNED PROPERTY

- 1. Identify lots to sell, take to Township Board for authorization to enter into negotiations for sale of the property.**
- 2. Conduct a valuation of the property based upon Assessing Department review and analysis. Determine the asking price as a starting point of negotiation.**
- 3. Send letter to adjacent home owners. Priority is given to owner occupied homes.**
- 4. Negotiate a sale price. No land contracts. Township will hold offer, assuming no other offer is received, up to 6 months or an otherwise agreed upon time period for buyer to pay.**
- 5. Consent from Township Supervisor and Legal Counsel to proceed and prepare Letter of Agreement with buyer to take to the Township Board.**
- 6. As a requirement to purchase the property, lots must be maintained and meet the criteria of the Ypsilanti Township Ordinance and all other specific requirements from the Township as agreed upon within the letter of agreement.**
- 7. Present offer to the Ypsilanti Township board for their approval.**
- 8. Closing. Quit Claim deed to be prepared and signed by Township Officials. The buyer pays Township by certified check. Buyer is responsible for paying all closing costs associated with the purchase of the property, if applicable.**

Supervisor
BRENDA L. STUMBO
Clerk
KAREN LOVEJOY ROE
Treasurer
LARRY J. DOE
Trustees
JEAN HALL CURRIE
STAN ELDRIDGE
MIKE MARTIN
SCOTT MARTIN



Charter Township of Ypsilanti

Assessor's Office

7200 S. Huron River Drive
Ypsilanti, MI 48197
Phone: (734) 487-4927
Fax: (734) 484-5159

Date: October 8, 2015

To: Karen Lovejoy Roe,
Ypsilanti Township Clerk

From: Brian McCleery,
Assistant Assessor

Subject: Approval of Property Sale to Mr. Ellicott
K-11-11-202-004 and K-11-11-202-040

Assessor's Office is requesting approval to finalize the sales of the above properties to Mr. Ellicott for \$2,500.

The above properties are two unbuildable land locked parcels that are behind and adjacent to Mr. Ellicott's primary residence of 36 Ohio St. Mr. Ellicott has agreed to combine the above properties with his existing home into one resulting parcel. Mr. Ellicott has also agreed to maintain the property and will be fencing it next year.

Also attached you will find the letter of agreement and an aerial photograph map of the property. If you have any questions or need more information, **please don't hesitate contacting me.**

Supervisor
BRENDA L. STUMBO
Chief of Agreement- Continued
KAREN LOVEJOY ROE
Treasurer
LARRY J. DOE
Trustees
JEAN HALL CURRIE
STAN ELDRIDGE
MIKE MARTIN
SCOTT MARTIN



Charter Township of Ypsilanti

Assessor's Office

7200 S. Huron River Drive
Ypsilanti, MI 48197
Phone: (734) 487-4927
Fax: (734) 484-5159

Letter of Agreement

October 7, 2015

Erick Ellicott
36 Ohio St
Ypsilanti, MI 48197

Dear Mr. Ellicott,

This letter (the "Agreement") summarizes the understanding of the agreement that we reached during our meeting on September 25, 2015. If this Agreement is acceptable to you, please sign below in the space designated for your signature.

The agreement is as follows:

1. Agreement

The following is agreed upon for the Purchase of Township Owned Property:

The two properties listed below will be purchased for the combined price of \$2,500 paid by certified check. The Property is to be combined with purchaser's primary residence parcel at 36 Ohio St, parcel id K-11-11-202-035

Parcel **K-11-11-202-004** described as:
Lot 598 Except the South 30 feet and all of lots 599 and 600
Devonshire Sub #4

Parcel **K-11-11-202-040** described as:
The North 30 feet of lot 597 and the South 30 feet of lot 598
Devonshire Sub #4

2. Term

The term of this Agreement ("Term") will commence as of October 7, 2015 and will continue to be in effect for 6 months or until April 7, 2016, at which point it

Letter of Agreement- Continued

shall terminate, unless the Term is extended or terminated earlier in a written document signed by both parties.

3. Closing

For the agreed upon sum of \$2,500 paid in full by certified check, Ypsilanti Township agrees to sell the above described properties to you via the recording of a Quit Claim Deed in the name of Eric & Clair Ellicott.

4. Termination

This agreement shall terminate upon the closing of the sale of the above property or the expiration of the Term after April 7, 2016.

If the above correctly expresses your understanding of the terms reached during the negotiations, please sign and date a copy of this Agreement and return the signed and dated Agreement to me.

Charter Township of Ypsilanti
7200 S. Huron River Dr.
Ypsilanti, MI 48197

Accepted and agreed to on Oct 7, 2015 by



Eric Ellicott

Aaron Dietz
Notary Public, Washtenaw County, MI
My Commission expires Nov. 13, 2017



Notary Public, Washtenaw County
My Commission Expires on 11/13/17

-036

K-11-11-202-036

360 Hio

-035

K-11-11-202-035

-004

K-11-11-202-004

-034

-034

-033

K-11-11-202-033

-040

K-11-11-202-040

-032

CONRALL

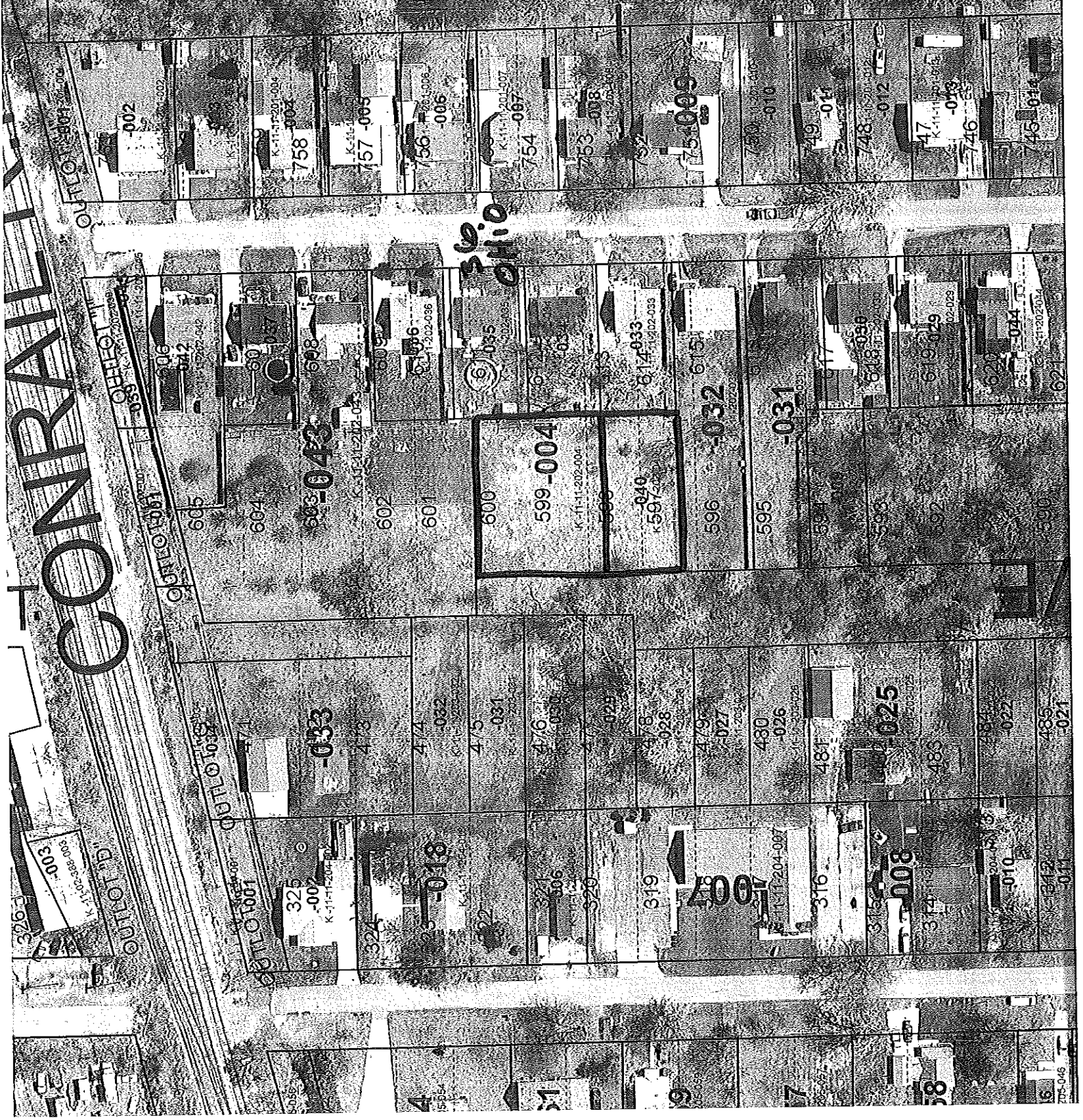

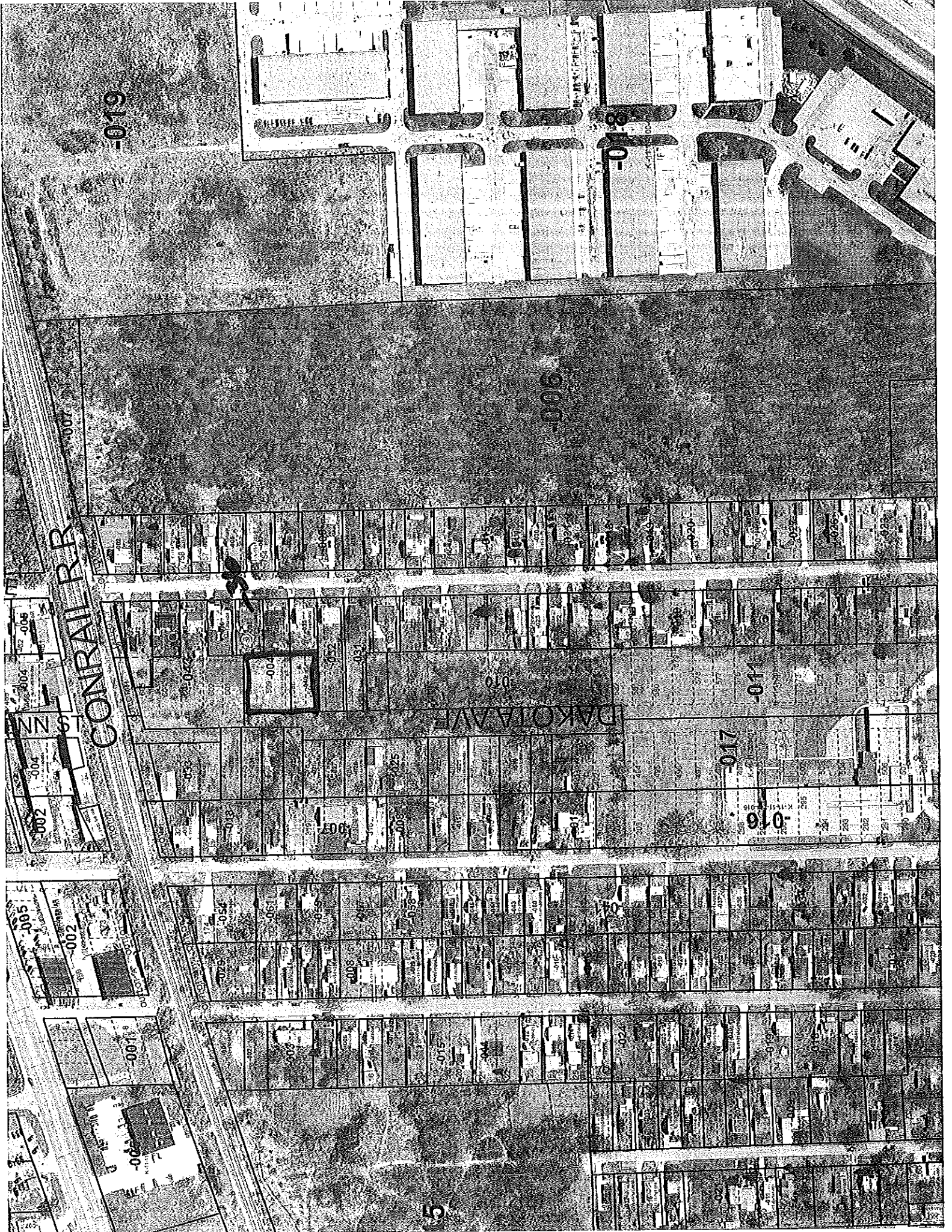

Resolution 2015-44

In Honor of Rosie the Riveter Day
October 24, 2015

WHEREAS American women entered the workforce in unprecedented numbers during World War II, as widespread male enlistment left gaping holes in the industrial labor force; and

WHEREAS between 1940 and 1945, the female percentage of the U.S. workforce increased from 27 percent to nearly 37 percent, and by 1945 nearly one out of every four married women worked outside the home; and

WHEREAS the Willow Run Bomber Plant was constructed in the early years of World War II by Ford Motor Company for the mass production of war munitions, especially the B-24 Liberator heavy bomber; and

WHEREAS “Rosie the Riveter,” star of a government campaign aimed at recruiting female workers for the munitions industry, became perhaps the most iconic image of working women during the war; and

WHEREAS Henry Ford employed "Rosie the Riveters" on his assembly lines at the Willow Run Bomber Plant and throughout America; and

WHEREAS at its peak, the historic plant produced one B-24 per hour; and

WHEREAS in March 2014 at the historic Willow Run Bomber Plant site, the Guinness World Record was set by having the most “Rosie the Riveters” in one place with 778; and

WHEREAS in August 2015, the Guinness record was taken by Richmond, California with 1,084 “Rosies”; and

WHEREAS on October 24, 2015, we will be joining forces with women across the State of Michigan to take our record back;

NOW THEREFORE BE IT RESOLVED, that the Charter Township of Ypsilanti Board of Trustees does hereby proclaim October 24, 2015 as “Rosie the Riveter Day” in Ypsilanti Township and honor all the women who answered the call to help our great nation and forever changed the opportunities for women in the workforce.

CHARTER TOWNSHIP OF YPSILANTI

To: Karen Lovejoy Roe, Clerk
From: Mike Radzik, OCS Director
Re: Request authorization to seek legal action to abate public nuisances at properties located at 881 Allen, 535 Glenwood, 1847 Watson and 582 Onandaga in the amount of \$20,000, with legal action budgeted in line item #101.950.000.801.023
Date: October 13, 2015
Cc: Board of Trustees
Doug Winters, Township Attorney

The Office of Community Standards has conducted investigations of four (4) vacant, abandoned houses and seeks authorization to proceed with legal action (if necessary) in Washtenaw County Circuit Court to abate the public nuisances that exist at:

881 Allen Road

This single family house has been vacant for more than one year following foreclosure by HSBC Bank. Since then, ownership of the property has been transferred between several financial institutions and is now held by Kaja Holdings 2, LLC of Columbia, South Carolina. The house was inspected by administrative warrant on February 10, 2015 after several scheduled inspections were ignored. The inspection revealed electrical code violations that rendered the structure uninhabitable. Most recently the home was temporarily occupied by an individual who was attempting to purchase it, however the purchase fell through and the home remains vacant.



535 Glenwood

This single family house is owned by Kathryn Fleming who resides in Chandler, AZ and has been vacant for about one year. It was reported to be vacant and abandoned by neighbors and the Township has mowed the grass all year and recently boarded up an open, damaged door. After unsuccessful attempts to get the owner to register the property and schedule an inspection, the property was inspected by administrative warrant on September 17, 2015. The house is infested with rodents and the detached garage is structurally failing. Despite water service having been terminated, water was found spewing from a broken pipe in the crawl space underneath the floor. The house has been condemned and the owner has not taken action to abate the nuisance.



1847 Watson

This house has been vacant for at least five years and was prepared for demolition in 2010; however the owner never followed through after obtaining a demolition permit. The owner, Christopher Kind II, also owns a house at 20 Devonshire Rd in Ypsilanti Twp and has not responded to numerous correspondences from OCS. The house was inspected by administrative warrant on September 14, 2015 and was found to contain hundreds of discarded automobile tires which present a serious environmental hazard in the event of a fire. The house is so packed with tires that inspectors were unable to navigate to the second floor of the house to complete the inspection. The property is condemned and will require removal and disposal of the tires prior to demolition of the structure.



1847 Watson

582 Onandaga

This single family house in the West Willow neighborhood has been vacant for more than five years after its owner relocated and utility services were terminated in 2010. It was registered as vacant by Safeguard Properties on behalf of Chase Bank on April 21, 2015 and the bank did not show up for a scheduled inspection. The house was inspected by administrative warrant on August 17, 2015 and was condemned. Subsequent to the inspection the owner, Beverly Walls, contacted OCS and indicated she was living elsewhere, was negotiating with Chase Bank to retain the property, and the house had been burglarized while vacant. A police records check showed that two burglaries were investigated in 2013 and 2014 during which copper pipes, electrical wiring, appliances and tools were reported stolen and the owner told police the house was being renovated for use as a rental property. It remains vacant and condemned and further efforts to gain voluntary compliance have been unsuccessful.



582 Onandaga

OTHER BUSINESS

AUTHORIZATIONS AND BIDS

Supervisor
BRENDA L. STUMBO
Clerk
KAREN LOVEJOY ROE
Treasurer
LARRY J. DOE
Trustees
JEAN HALL CURRIE
STAN ELDRIDGE
MIKE MARTIN
SCOTT MARTIN

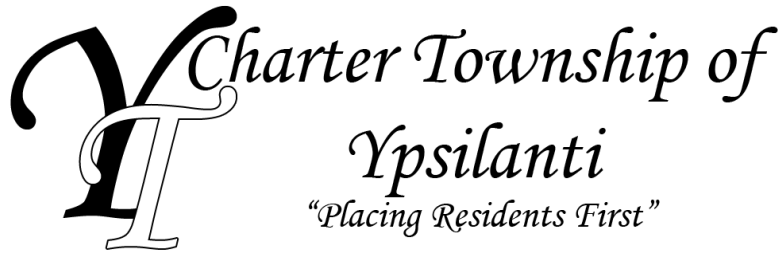

Residential Services

7200 S. Huron River Drive
Ypsilanti, MI 48197
Phone: (734) 484-0073
Fax: (734) 544-3501
www.ytown.org

MEMORANDUM

TO: Charter Township of Ypsilanti Board of Trustees

FROM: Jeff Allen, Director of Residential Services

DATE: September 29, 2015

RE: Approval for seeking RFP for 2016 printing packet

We are requesting Township board approval to seek proposals for the 2016 "Helpful Handbook".

In past years, the environmental services division has mailed out an annual magnet schedule and information to our residents. In 2011, we changed this to include all departments, including specific information for residents as it relates to all of the departmental contacts at the Township.

We are again planning on going forward with the printing and mailing of some 15,000 packets to allow for easy reference by residents. This would also include a separate mailing for multi-family units.

We anticipate the cost to be not to exceed \$25,000 for the printing of the materials, \$4,000 for magnets and another \$6,000 for mailing the pieces and will bring the bids back to the board for final approval.

The charges for this would be divided up between the following:

226.226.000.900.000
226.226.000.730.000
212.212.000.900.000
212.212.000.730.000



Office (734) 544-4225
Fire Chief (734) 544-4110
Fire Marshal (734) 544-4107
Fax (734) 544-4195

FIRE DEPARTMENT
222 SOUTH FORD BOULEVARD
YPSILANTI, MICHIGAN 48198-6067

MEMORANDUM

To: Charter Township of Ypsilanti Board of Trustees

From: Ypsilanti Township Fire Chief Eric Copeland

Date: October 12, 2015

Subject: Request Authorization to Amend the Cost of the Fire Station Headquarters Roof Replacement by an Increase of \$3,500.00 for a Total Amount of \$53,450.00 Budgeted in Line Item #206-970-000-971-008

A bid in the amount of \$49,950.00 was approved by the Board of Trustees at the October 6, 2015 Regular Meeting for replacement of the roof at Fire Station Headquarters. It has since come to my attention that the bid amount received from Rapid Roofing would need to increase by \$2,500.00 to include the cost of the performance bond they are required to have for this project.

I would also request to include a contingency amount of \$1,000.00 for replacing damaged underlayment in the roof for up to 15 sheets of plywood and/or 300 lineal feet of 1x6 board (5 sheets of plywood are included in the original bid from Rapid Roofing). It will not be known how many, if any, sheets need to be replaced until the current roof is removed.

This increase in cost for the roof replacement of \$3,500.00 will bring the total project costs to \$53,450.00. With this increase, Rapid Roof is still our lowest bidder by \$4,314.00.

If you have any questions, please feel free to contact me.

Sincerely,

Fire Chief Eric Copeland



Restoring Your Peace-of-Mind...FAST!

*This proposal was prepared just for you:
Ypsilanti Township Fire Department
222 S Ford Blvd
Ypsilanti, MI 48198
734-544-4100*



September 21, 2015

Ypsilanti Township Fire Department,

Thank you for taking the time to meet with me and discuss ideas for your home improvement. I would briefly like to tell you about Rapid Roofing and why you will want to choose us for your home improvement project.

Rapid Roofing provides \$2,000,000.00 of liability insurance per occurrence. All of our employees are covered by Workers Compensation Insurance so that you will not be exposed to any liability should any of our employees be injured while on your job. We are registered with the State of Michigan as a licensed building contractor.

- We are members of Certified Contractors Network (CCN)
- We are members of Better Business Bureau (BBB)
- We are members of National Roofing Contractors Association (NRCA)
- We are members of the following Chamber of Commerce: Novi, Northville, Livonia, Plymouth, Canton, Belleville, Farmington, Farmington Hills, and Birmingham

As a legitimate and dependable home improvement company, we maintain these affiliations and credentials to provide you with the highest level of confidence and customer service. We are registered, licensed and approved with many manufacturers for the installations of premium home improvement products.

- Our roof mechanics are qualified Master Shingle Applicators (MSA), and attend pre-approved on-going training to keep them up to date on the latest technological advances in the roofing industry including the local building codes and the NRCA specifications. We are also a GAF-ELK MasterElite Contractor

(ME04316).

- Our installers are certified by GAF-ELK, Owens Corning, Certainteed, DECRA metal shingles, and (GAF Commercial) among others.

With a permanent place of business and over 10 years in the home improvement industry, we take pride in our quality workmanship and the specialty services offered to our clients.

We thank you for giving us the opportunity to help you meet your home improvement needs and look forward to helping you achieve 100% customer satisfaction.

Very Truly Yours,

Michael L. Beaty
Rapid Roofing

Deteriorated Roof Removal:

Rapid Roofing will remove and dispose of the existing layers of deteriorated roof material, down to the existing roof deck.

Deck Preparation:

The roof deck is the structural surface over which the roofing materials are applied. The roof deck should be a smooth, solid surface, which will permit the panels to be securely fastened. The roof deck should be at least 1/2" thick plywood or nominal 1" thick wood deck, not more than 6" wide. The deck must be strong enough to:

- Support the roofing materials and our workers.
- Safely resist impact loads.
- Hold uniform loads, such as heavy snow.
- Provide resistance to wind force.
- Anchor the nails.

If you apply a roof over a deck surface that is unacceptable to the manufacturer, and damage results, the warranty may not be honored. The manufacturer will not take the responsibility for:

- Poor deck design that causes damage to the roofing system or other parts of the house.
- Defects or damage caused by the materials used as a roofing base, over which the metal roofing is applied.
- Damage to the roofing material caused by settlement, distortion, failure, or cracking of the roof deck.
- Defects, damage or failure caused by the application of the metal roofing not in strict adherence within written instructions of the manufacturer.
- Application over wood that is not dry or which has hard projections, such as partially driven nails, which can cause damage to the roofing material or underlayment applied above.

- 1. Inspect entire roof deck before the installation of the new roofing, re-nail protruding roof nails and clean the roof deck to allow for a smooth surface for the installation of the new metal roof panels.**
- 2. Any replacement of rotted or damaged decking, framing or finishing lumber charged at: \$45.00 per sheet of plywood and \$3.00 per lineal ft. of 1x6.**
- 3. Labor will be charged at a rate of \$75 per man hour plus materials on areas that have not been specified.**

Rapid Roofing will notify the customer prior to proceeding with the above additional work.

New plywood deck areas:

- Furnish and install up to 5 sheets of new roof decking, new decking will be properly spaced with galvanized steel clips and fastened with ZipFit hidden hangers.

Perimeter Edge Flashing (Drip Edge):

Eave Drip Edge Flashing:

Install 20 ounce copper drip edge on all eave edges beneath underlayment to facilitate water run off into gutters or away from house.

Rake Drip Edge Flashing:

Install 20 ounce copper drip edge on all rake edges on top of underlayment to protect against wind driven rain.

Areas Ice & Water Shield is to be installed:

Install (36") of ice and water shield around all roof penetrations including chimneys and vent pipes.

Additional areas Ice & Water Shield is to be installed:

For an asphalt shingle roof system 9' will also be installed at the eaves as well as 18" along the rake edge.

NOTE: For an asphalt shingle roof system, ice shield to be installed by qualified mechanics for manufacturers extended Pro Warranty.

Ice & Water Shield:

Ice & Water Shield: Ice & Water Shield offers leak protection for sloped roofs due to ice dams and wind-driven rain. It is applied to the roof deck prior to the application of the finished roof covering. The membrane goes under shingles and seals around nails that hold the shingles in place, so water that doesn't drain properly cannot penetrate the roof. It also creates a weather-tight barrier against wind-driven rains that cause shingles to lift and leak.



- Ice & Water Shield is warranted to remain effective during the warranted lifetime of a new asphalt shingle system applied over it.
- Ice & Water Shield is a long lasting, waterproofing shingle underlayment designed to seal the roof and prevent water from getting inside the building.
- Ice & Water Shield protects your building from water backup caused by ice dams & wind-driven rain.

Underlayment:

Underlayment shall consist of (1) layer of Tamko Synthetic roofing underlayment secured to the roofdeck.

Roofing underlayment is available in several grades and composition. Typical underlayment is commonly known as #15 or #30 felt. This name no longer reflects the product's weight. These underlayments are water resistant to some degree, depending on the percentage of asphalt that has been absorbed into the felt or fiberglass mat. The best underlayments adhere to ASTM standards. ASTM D2869 for #15 underlayment and ASTM D226 for #30 underlayment. The installation of standard underlayment is required by most shingle manufacturers and recommended by all. Shingle underlayment is required by Underwriters Laboratories (UL) for a Class A fire rating. The roofing industry is rapidly changing to synthetic underlayments, because they consistently out-perform & out-test conventional roofing underlayments.

Benefits of Tamko Synthetic Underlayment:

- Lays flat and is extremely resistant to wrinkling
- Reduces the likelihood of slipping for increased safety
- Won't tear away from fasteners when walked on or in strong winds
- Can be left exposed for long periods of time
- High-tech, high performance roofing underlayment

Roof Installation:

Furnish and install a Tamko roof system as per manufacturers specifications and in accordance with the selected material and warranty guidelines.

- Rapid Roofing will install a Tamko roof system per manufacturers specifications .
- All shingles to be sealed at the perimeter then sealed to the drip and rake flashings Tamko starter strip.

Valley Installation:

- Furnish and install 3 layers of new Ice and Water shield within all valleys after installation of new Ice and Watershield .20 ounce custom fabricated W Style Aluminum Valley will be installed. This will prevent premature failure and insure that the new valleys will be permanently sealed.

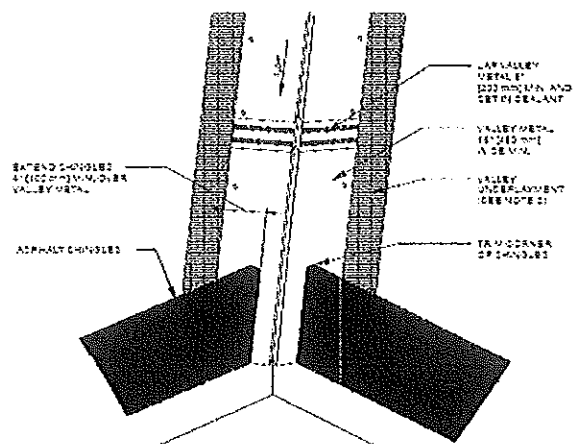

Fasteners for Roofing Application:

- Nailing of shingles vary, Rapid Roofing installs all shingles with 1 1/2" hot dipped galvanized ring shanked nails (6 per shingle).
- Fastener must be placed correctly in every shingle, penetrate thru plywood roof deck by a minimum of an 1/8" and a minimum 3/4" into solid wood deck.
- It is Rapid Roofing policy not to staple shingles ever.

Ventilation:

As required by building codes and The National Roofing Contractors Association (NRCA) your roofing system will require the following ventilation:

All insulated attic spaces shall be ventilated with openings to the exterior of not less than 1 square foot (minimum) of ventilation for every 300 square feet of attic floor space. This must be balanced equally between the soffit and the ridge of your home.

- All ventilation shall be designed to prevent the entry of rain and snow and insects.
- Furnish and install LAMANCO 750 Roof Louver ventilation system on all peaks of the home.
- 16,000 sq. ft. of attic floor divided by 300 = 54 square feet of net free ventilation
- Convert to square inches 54 sq. ft. x 144 = 7,776 sq. inches
- Balance system by dividing by 2 = 3,888 sq. inches of intake and exhaust (minimum)
- Ridge ventilation only provides a maximum of 18 net free inches per lineal ft 18 net free inches x 116 lineal ft = 2,088 which is 1,800 net free inches less of the manufacturer and local building code minimum requirement. The only way to properly ventilate the buildings attic space properly is with a Roof Louver Ventilation System.

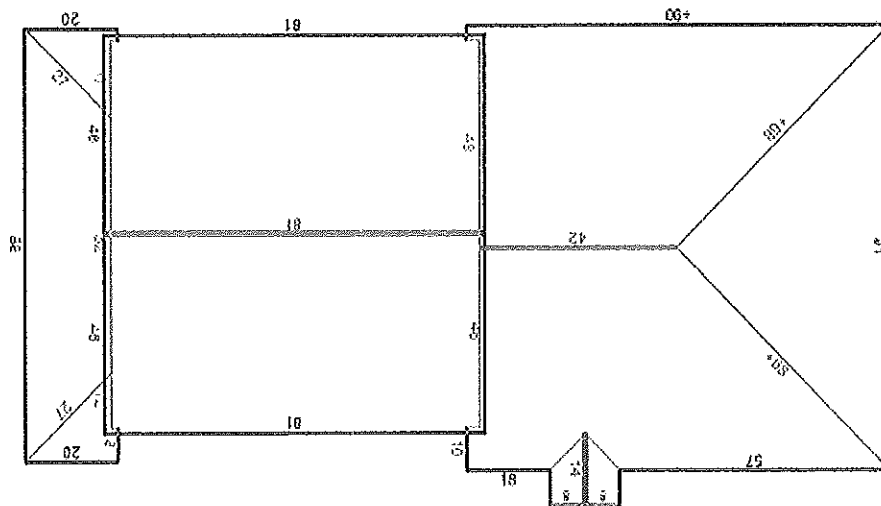

IMPROPER VENTILATION WILL VOID MANUFACTURERS WARRANTY!

Flashings: (if applicable)

- ~~Chimney~~ **Flashings**: flashings around perimeter of all applicable chimneys. Apply Ice & Water Shield new step flashing counter flashing around entire perimeter of chimney base.
- **Plumbing Vent Flashings:(if applicable)** replace all plumbing vent flashings with new boot which will be custom fabricated for your roof system.

Permits: (if applicable)

All applicable permits & inspection fees pertaining to job will be applied for & obtained by Rapid Roofing for the scope of work being performed in their respective township, city or village. Permits for roofing projects are a requirement in certain townships or municipalities by local building codes.

Non-Standard Items:

- Not applicable

Low sloped roof areas:

- Not applicable

Long Term Warranty:

Rapid Roofing is a Professional Roofing Contractor certified by TAMKO AS A PRO CONTRACTOR. Rapid Roofing proposes to furnish and install labor and material in accordance with the above specifications in order to qualify for the Manufacturers Long Term Warranty. A Certificate of Warranty for materials must be prepared & mailed to manufacturer upon completion of the roof. A warranty will be provided to you for the term specified by the material chosen.

ROOFING INVESTMENT

Entire Building

TAMKO HERITAGE WOODGATE

- Lifetime Limited Transferable Warranty
- 30-yr Non-Prorated
- Two-piece laminated shingle construction
- Fiber Glass composition
- 15yr. Algae-Resistant warranty
- UL Class A Fire Resistance
- Wind Warranty up to 130 mph
- ASTM D3161 (Self Sealing)
- ASTM D3462 (Tear Strength)

\$55,550.00

Accepted _____ Rejected _____

OPTIONS & ACCESSORIES		INVESTMENT
Roof		\$55,550.00
10 % donation to the fire station		\$ 5,550.00
Performance Bond if Required 5% project cost		\$ 2,497.50 not included
	TOTAL	\$49,950.00
0 % due upon acceptance	Deposit	\$ 0.00
Balance due upon completion	Balance	\$49,950.00
YOU, THE OWNER MAY CANCEL THIS TRANSACTION AT ANY TIME PRIOR TO MIDNIGHT OF THE THIRD BUSINESS DAY AFTER THE DATE OF THIS TRANSACTION. SEE THE NOTICE OF CANCELLATION CLAUSE BELOW FOR AN EXPLANATION OF THIS RIGHT.		

ACCEPTED AND AGREED: The prices, specifications and conditions contained herein this Agreement are satisfactory and hereby accepted. You are authorized to perform the work as specified.
(MUST BE SIGNED BY ALL OWNERS)

OWNER: _____

DATE: _____

AGREEMENT IS NOT FULLY EXECUTED UNTIL SIGNED BY A LICENSED SALES PERSON THAT IS CURRENTLY EMPLOYED BY Rapid Roofing.

Michale L Beaty

Michael L. Beaty

DATE: 9/22/2015

Supervisor
BRENDA L. STUMBO
Clerk
KAREN LOVEJOY ROE
Treasurer
LARRY J. DOE
Trustees
JEAN HALL CURRIE
STAN ELDRIDGE
MIKE MARTIN
SCOTT MARTIN



Charter Township of Ypsilanti

**Green Oaks
Golf Course**

1775 E. Clark Road
Ypsilanti, MI 48198
Phone: (734) 485-0881
Fax: (734) 485-1992

From: Director of Golf, Justin Blair, PGA

Date: 10/15/2015

Subject: Request authorization to waive financial policy and award low bid to Eagle Golf Construction, in the amount of \$19,087.50 budgeted in line item #584-584-000-971-000.

Over the years, due to poor drainage Green Oaks Golf Course has had issues with its greens. The low areas would collect the water that would not drain, causing the grass on the green to thin almost to the point of dying. If the water either drained or evaporated quickly enough the green would recover somewhat, and the cycle would repeat after the next big rain fall.

In the last two years due to extensive ice damage from two winters ago and record setting rainfall, the number 3 green has not been able to recover and grass in specific areas will not grow back. We have tried re-sodding, but due to the poor drainage and the low spot in the green the grass dies off almost immediately after any rainfall. Earlier this season we closed half of the green off and tried over seeding and keeping golfers off of the bad areas in an effort to help it grow in with some success, but the problem will persist if it not permanently addressed.

After speaking with golf course architect Chris Wilzynski, ASGCA he recommended that we start to consider the renovation of the green to completely fix the problem. Chris was able to work up all of the specifications on what would be needed for the project and was also able to put us in touch with the golf construction companies that are capable and have the references to complete the project.

With dramatic changes in the weather restricting the time frame to complete the renovation of the green we want to complete the project while the soil is still warm, so that the new sod can take root and ensure that it will grow well in the spring.

Thank you in advance for your time and consideration.

Sincerely,

Justin Blair, PGA
Director of Golf
Green Oaks Golf Course



October 15, 2015

Green Oak Golf Course
1775 E. Clark Road
Ypsilanti, MI 48198

Re: Bid

Dear Sirs,

Thank you for this opportunity to introduce Eagle Golf Construction, Inc. and allowing us to bid on the Green Oak Golf Course for holes 2, 3, and 5 greens. Our Website lists all projects in the past from 2012 and beyond and it can be found at www.EagleGolfConstruction.com.

I started Eagle Golf Construction in 1989. And I personally began my golf construction career in 1985. Eagle Golf has had the great opportunity working on a total of 45 plus golf course construction projects throughout the U.S. and Mexico. We have worked with 30 plus of the finest golf course architects and designers along the way (Palmer, Nicklaus, Ault/Clark, Hills, Love, Fazio, LaFoy, Cupp). And, we have managed and participated on projects budgeted from \$5,000.00 to \$13 million. What separates us from other companies is our personal attention to "one project at a time" approach, as well as the quality that is implemented from 30 years of experience with so many talented architects/designers. To top it off, I am also an accomplished shaper (without ego) to aid in this project. This is why Eagle Golf Construction is your partner in this rebuild project.

The following is a description of our company and affiliates:

Firm Name & *Eagle Golf Construction, Inc.*

Billing Address:

PO Box 807

Hartland, MI 48353-0807

810.632.6270

Point of Contact:

E. Randal Pichan, President

Cell #: 810.240.7961

Corporate Banking:

J.P. Morgan Chase Bank

10083 Highland Road

Hartland, MI 48353

Ph.810.632.9567

Bonding Agency:

Mourer-Foster, Inc.

Mr. John Foster

615 N. Capitol Avenue

Lansing, MI 48933

ph. 517.371.2300

Insurance Agency:

The Insurance Exchange

Northville, MI

Representative: John Maloney

Cell#: 248.207.5709

Tricia Neville

Ph. 248.869.8017

Certifications/Memberships:

Member of Golf Course Builders Assoc. of America

MiGCSA

Michigan Turfgrass Foundation

Representative Courses:

Wanakah Country Club, Buffalo, NY (Construction)

**The Golf Club @ Harbor Shores, Benton Harbor, MI
(Construction)**

**The Tatanka Golf Club, Niobrara, NE
(Construction & Irrigation)**

Best regards,

E. Randal Pichan

GREEN OAKS GOLF COURSE
Ypsilanti Township, Michigan

Name: Eagle Golf Construction, Inc.
Date: 10/15/15
 Randal Pichan, President

Bid Proposal for Renovation of Greens #2, #3 and #5

<u>ITEM</u>	<u>PRICE</u>	<u>QTY.</u>	<u>UNIT</u>	<u>TOTAL</u>
Site Preparation				
Mobilization and Demobilization	\$1,500.00	1	LS	\$1,500.00
Site Preparation Total:				\$1,500.00
Green Drainage (hole #3)				
Install 2" Micro-Slit Plastic Drain Pipe (6' O.C.) with 60:20:20 organic USGA sand mixture backfill (includes strip of exsiting greens sod)	\$0.88	5,500	SF	\$4,840.00
Install 4" Solid HDPE drainage pipe for outlet from Greens Drainage	\$6.25	50	LF	\$312.50
Hole #3 Green Drainage Total:				\$5,152.50
Green Renovation (hole #3)				
Strip and Dispose of Existing Turf, Regrade Green Surface (cut and fill balance with existing greens soil), Install New Bentgrass Greens Sod	\$2.09	5,500	SF	\$11,495.00
Hole #3 Green Renovation Total:				\$11,495.00
Green Drainage (hole #2)				
Install 2" Micro-Slit Plastic Drain Pipe with 60:20:20 organic USGA sand mixture backfill (includes strip and replacement of exsiting greens sod)	\$5.75	60	LF	\$345.00
Install 4" Solid HDPE drainage pipe for outlet from Greens Drainage	\$6.25	20	LF	\$125.00
Hole #2 Green Drainage Total:				\$470.00
Green Drainage (hole #5)				
Install 2" Micro-Slit Plastic Drain Pipe with 60:20:20 organic USGA sand mixture backfill (includes strip and replacement of exsiting greens sod)	\$5.75	60	LF	\$345.00
Install 4" Solid HDPE drainage pipe for outlet from Greens Drainage	\$6.25	20	LF	\$125.00
Hole #5 Green Drainage Total:				\$470.00
PROJECT TOTAL:				\$19,087.50



**E&M GOLF
CONSTRUCTION**

64155 Vandyke Rd Ste. 141
Washington, MI 48095
(586) 651-6768

Project Manager: Eric Morrell
emorrell23@gmail.com
(312) 447-1110

GREEN OAKS GOLF COURSE		Name: E&M Golf Construction		
Ypsilanti Township, Michigan		Date: 10/15/2015		
Bid Proposal for Renovation of Greens #2, #3 and #5				
<u>ITEM</u>	<u>PRICE</u>	<u>QTY.</u>	<u>UNIT</u>	<u>TOTAL</u>
Site Preparation				
Mobilization and Debobilization	\$1,800.00	1	LS	\$1,800.00
Site Preparation Total:				\$1,800.00
Green Drainage (hole #3)				
Install 2" Micro-Slit Plastic Drain Pipe (6' O.C.) with 60:20:20 organic USGA sand mixture backfill (includes strip of exsiting greens sod)	\$1.10	5,500	SF	\$6,050.00
Install 4" Solid HDPE drainage pipe for outlet from Greens Drainage	\$6.50	50	LF	\$325.00
Hole #3 Green Drainage Total:				\$6,375.00
Green Renovation (hole #3)				
Strip and Dispose of Existing Turf, Regrade Green Surface (cut and fill balance with existing greens soil), Install New Bentgrass Greens Sod	\$1.70	5,500	SF	\$9,350.00
Hole #3 Green Renovation Total:				\$9,350.00
Green Drainage (hole #2)				
Install 2" Micro-Slit Plastic Drain Pipe with 60:20:20 organic USGA sand mixture backfill (includes strip and replacement of exsiting greens sod)	\$11.00	60	LF	\$660.00
Install 4" Solid HDPE drainage pipe for outlet from Greens Drainage	\$6.50	20	LF	\$130.00
Hole #2 Green Drainage Total:				\$790.00
Green Drainage (hole #5)				
Install 2" Micro-Slit Plastic Drain Pipe with 60:20:20 organic USGA sand mixture backfill (includes strip and replacement of exsiting greens sod)	\$11.00	60	LF	\$660.00
Install 4" Solid HDPE drainage pipe for outlet from Greens Drainage	\$6.50	20	LF	\$130.00
Hole #5 Green Drainage Total:				\$790.00
				PROJECT TOTAL: \$19,105.00

Proposed Project Start Date: October 26, 2015
Proposed Project Finish Date: November 2, 2015

GREEN OAKS GOLF COURSE

Name: Great Lakes Golf & Site Developm
1675 M-75 South
Boyne City, MI 49712
Ph: 231-582-6783
Christopher Furness, President

Ypsilanti Township, Michigan

Date:10/16/15

Bid Proposal for Renovation of Greens #2, #3 amd #5

<u>ITEM</u>	<u>PRICE</u>	<u>QTY.</u>	<u>UNIT</u>	<u>TOTAL</u>
-------------	--------------	-------------	-------------	--------------

Site Preparation

Mobilization and Debobilization	\$2,629.00	1	LS	\$2,629.00
---------------------------------	------------	---	----	------------

Site Preparation Total: \$2,629.00

Green Drainage (hole #3)

Install 2" Micro-Slit Plastic Drain Pipe (6' O.C.) with 60:20:20 organic USGA sand mixture backfill (includes strip of exsiting greens sod)	\$2.05	5,500	SF	\$11,275.00
---	--------	-------	----	-------------

Install 4" Solid HDPE drainage pipe for outlet from Greens Drainage	\$12.50	50	LF	\$625.00
---	---------	----	----	----------

Hole #3 Green Drainage Total: \$11,900.00

Green Renovation (hole #3)

Strip and Dispose of Existing Turf, Regrade Green Surface (cut and fill balance with existing greens soil), Install New Bentgrass Greens Sod	\$2.48	5,500	SF	\$13,640.00
--	--------	-------	----	-------------

Hole #3 Green Renovation Total: \$13,640.00

Green Drainage (hole #2)

Install 2" Micro-Slit Plastic Drain Pipe with 60:20:20 organic USGA sand mixture backfill (includes strip and replacement of exsiting greens sod)	\$2.05	60	LF	\$123.00
---	--------	----	----	----------

Install 4" Solid HDPE drainage pipe for outlet from Greens Drainage	\$12.50	20	LF	\$250.00
---	---------	----	----	----------

Hole #2 Green Drainage Total: \$373.00

Green Drainage (hole #5)

Install 2" Micro-Slit Plastic Drain Pipe with 60:20:20 organic USGA sand mixture backfill (includes strip and replacement of exsiting greens sod)	\$2.05	60	LF	\$123.00
---	--------	----	----	----------

Install 4" Solid HDPE drainage pipe for outlet from Greens Drainage	\$12.50	20	LF	\$250.00
---	---------	----	----	----------

Hole #5 Green Drainage Total: \$373.00

PROJECT TOTAL: \$28,915.00